



TARPING SYSTEMS & ACCESSORIES

P/N 1100496 Rev. T

OWNER'S MANUAL



PBR Premium Belt & Ratchet

READ BEFORE INSTALLING

PO BOX 713 ■ 2309 SHUR-LOK STREET ■ YANKTON, SD 57078-0713
PHONE 1-800-4-SHUR-LOK (1-800-474-8756) ■ FAX 605-665-0501
www.shurco.com

SHOP ONLINE: www.shopshurco.com

SHIPPING. Orders are shipped F.O.B. from the Shur-Co®, LLC sites listed below. No full freight is allowed or prepaid shipment accepted unless quoted and approved in writing prior to acceptance of the order. All shipments are made by the most reasonable means in accordance with size and weight of order, unless specified routing instructions are furnished by the customer. Shipments are made daily via U.P.S. and common carrier. Claims for shortages must be made within 10 days. All claims for damages or loss in transit must be made with the carrier. No collect calls will be accepted. To ensure delivery of orders, we need your full street address and phone number. When you receive your shipment, examine it carefully. Be sure all cartons listed on the delivery sheet are accounted for. Large items may be packaged separately. If a carton is damaged, open it and inspect the contents before signing for delivery. If merchandise is damaged, describe damage on the delivery receipt. Failure on your part to document damaged or missing merchandise on the delivery receipt releases the carrier of all liability; repair or replacement will be the customer's responsibility.

WARRANTY. We warrant all new products are free of defects in materials and workmanship.* This warranty is effective if products are properly installed and used for the purpose for which they were intended and applies to the original buyer only. Except as set forth above or in any product-specific warranty documentation, we make no other warranties, express or implied, including but not limited to warranties of merchantability of fitness for a particular use.

Returns of a product for warranty must be accompanied by a Return Merchandise Authorization number (RMA#), obtained by calling Customer Service at 866-748-7435, and sent, with freight paid by us, to Shur-Co®, LLC, 2309 Shur-Lok St., PO Box 713, Yankton, SD 57078. All products returned without an RMA# will be refused. When we issue the RMA#, we will also issue a call tag to have UPS (or other freight company) pick up the product. C.O.D. returns not accepted. We will pay no storage fees for a warranty product return prior to pick by us or the freight company. If a warranty product return is scheduled to be picked up by us, we will pick up the product at our earliest convenience.

If a product returned is found, in our judgement, to be defective in material or workmanship, our obligation under this warranty is limited to the repair or replacement of the product, which will be made by us. Repair or replacement will be at our discretion, with replacements being made using current products performing in the equivalent function. Labor charges, other than those incurred at our factory, including, but not limited to, any labor to install a repaired or replacement product, are not covered under this warranty. All expenses associated with delivering defective products to our factory and delivering repaired or replacement products from our factory to the owner will be paid by us.

If the product returned is found, in our judgement, to be non-warrantable, the owner will be contacted to authorize repair work, purchase of a replacement product or return of the product, all of which will be at the owner's expense. Payment authorization must be received by us before any non-warrantable product is repaired, replaced or returned. All expenses associated with delivering the repaired non-warrantable product, a replacement product or the non-warrantable product from our factory to the owner will be paid by the owner.

In no event will we be liable for any damages of any kind to person, product or property, including but not limited to indirect, incidental, special, consequential or punitive damages, or damages for loss of profits or revenue, even if we have been advised of the possibility of such damages. There are no warranties for used products or products that have been repaired, altered, modified or subjected to misuse, negligence or accident. We will not repair or replace products that fail or malfunction due to ordinary wear and tear, except as expressly noted in a product-specific warranty. Use of non-Shur-Co®, LLC parts in conjunction with Shur-Co®, LLC products will void this product warranty.

*Certain products have specific warranties that differ from this warranty, for example motors and electronics. Product-specific warranty documentation is available for these items. In the event of a conflict between this warranty and a product-specific warranty, the product-specific warranty will govern.

RETURN POLICY. All sales final. See WARRANTY above for return details.

OTHER. All prices, product listings, sizes, weights and manufacturing details are subject to change without notice. No person is authorized to modify the foregoing conditions of sale whatsoever.

SHUR-CO® , LLC SERVICE AND DISTRIBUTION CENTERS

Corporate HQ and Outlet Store

SHUR-CO® of SOUTH DAKOTA

2309 Shur-Lok St., PO Box 713
Yankton, SD 57078-0713
Ph 800.474.8756 | Fax 605.665.0501

ShurTite™ Service Centers

SHUR-CO® of CANADA

490 Elgin St., Unit #1
Brantford, Ontario N3S 7P8
Ph 800.265.0823 | Fax 519.751.3997

SHUR-CO® of SIOUX FALLS

47184 258th St., Suite B
Sioux Falls, SD 57107
Ph 844.573.9322 | Fax 605.543.5469

SHUR-CO® of ILLINOIS

Ph 866.356.0246 | Fax 217.877.8270

SHUR-CO® of OHIO

Ph 866.356.0242 | Fax 330.297.5599

SHUR-CO® of FLORIDA

3353 SE Gran Park Way
Stuart, FL 34997
Ph 800.327.8287 | Fax 772.287.0431

SHUR-CO® of ILLINOIS

3993 E. Mueller Ave.
Decatur, IL 62526
Ph 866.356.0246 | Fax 217.877.8270

SHUR-CO® of IOWA

3839 Midway Blvd.
Ft. Dodge, IA 50501
Ph 866.356.0245 | Fax 515.576.5578

SHUR-CO® of MICHIGAN

5100 Lakeshore Dr.
Lexington, MI 48450
Ph 800.327.8287 | Fax 772.287.0431

SHUR-CO® of NORTH DAKOTA

1746 4th Ave. NW
West Fargo, ND 58078
Ph 877.868.4488 | Fax 701.277.1283

SHUR-CO® of OHIO

1100 N. Freedom, St. Rt. 88 & 14
Ravenna, OH 44266
Ph 866.356.0242 | Fax 330.297.5599

SHUR-CO® UK, Ltd.

Unit 41 Rochester Airport Estates
Laker Rd., Rochester, Kent ME1 3QX
Ph +44 (0)1795.473499
Fax +44 (0)871.272.8278

For more info, log on to our website:

www.shurco.com

MESSAGE TO OWNERS

Thank you for buying this tarping system from Shur-Co®. We appreciate your confidence in our products. Please read and thoroughly understand this manual before installing and/or operating this system.

Pay particular attention to important safety and operating instructions, as well as warnings and cautions. The hazard symbol  is used to alert users to potentially hazardous conditions and is followed by caution, warning or danger messages.

Failure to READ AND FOLLOW INSTRUCTIONS could result in failure of your tarping system and/or personal injury. Your trailer requirements may, however, call for minor variations to these instructions.

Please inspect your tarping system periodically. Repair or replace worn or damaged parts to your system.

QUESTIONS? CALL OUR HELP LINE:

1-866-748-7435

MON-FRI 8 AM-5 PM CENTRAL TIME

SAFETY

We at Shur-Co® are concerned with your safety and the safety of all those operating this system. Therefore, we have provided safety decals at various locations on your tarping system. Keep decals as clean as possible at all times. Replace any decal that has become worn or damaged, painted over or otherwise difficult to read. Replacement decals are available through Shur-Co® dealers.

SAFETY INSTRUCTIONS

1. Always wear safety glasses during installation.
2. Keep body and clothing clear of moving parts.
3. Do not walk on or stand on end caps.
4. Return bows to secure position after operation.
5. Use only OSHA-approved ladders or scaffolding during installation process.
6. Close tarp securely before traveling at highway speed.
7. No other use of this system is authorized, except as designed.

RUST PREVENTION

To prevent rust, paint all exposed metal, such as weld seams and/or metal exposed by grinding or cutting, with corrosion-resistant paint.

TABLE OF CONTENTS

Box Preparation..... 1

Hardware Identification..... 1

End Caps - Fabric Back.....2-4

End Caps - Aluminum..... 5

End Caps - Galvanized Steel 6

End Caps - Easy-Off..... 7

Bows - Standard Steel..... 8

Bows - Durabow™ 9

Bows - Aluminum..... 10

Bows - Heavy Duty..... 11

Ridge Straps - 1 Inch..... 12

Ridge Straps - 2 Inch..... 13

Ridge Straps - Metal Caps w/Hook 14

Ridge Strap - Fabric Caps w/Hook..... 15

Tarp Installation - Tarp Tubes 16-17

Tarp Installation - Standard Tarp Stops 18

Tarp Installation - Easy-Off Tarp Stops 19

Hold-Downs..... 20

Crank Arms - Standard..... 21

Poorboy Tail Flap Option 22

Removable Crank Option 23

Fixed Crank Option..... 24

Returns - Stretch Cord - Fixed Crank Option 25

Operation & Maintenance 26

Replacement Parts..... 27-36

Options & Upgrades 36

TOOLS REQUIRED

1. Welder
2. #3 Phillips Insert Bit or #3 Phillips Screw Driver (use with 13/64" drill bit)
3. #2 Phillips Screw Driver Bit
4. Air or Electric Wrench w/9/16" Socket
5. 9/16" Combination Wrench
6. 3/8" Drill
7. 3/16" Drill Bit
8. 13/64" Drill Bit
9. 1/4" Drill Bit
10. 5/16" Drill Bit (for 3/8" self-tapping screws)
11. 3/8" Drill Bit (for 3/8" cap screws)
12. 13/32" Drill Bit
13. Band Saw or Hack Saw
14. Grinder
15. Hammer
16. C-Clamps
17. Tape Measure



1704743 - Self-Drilling Screw - #10 x 1/2"

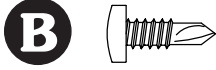

1700398 - Self-Drilling Screw - 1/4" x 3/4"



1704768 - Self-Drilling Screw - 1/4" x 3/4"

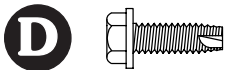

1700403 - Self-Tapping Screw-1/4" x 3/4"

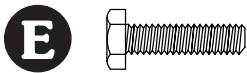

1700381 - Cap Screw - 1/4" x 1"

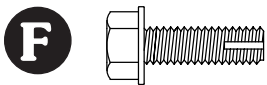

1701059 - Self-Tapping Screw - 5/16" x 1"

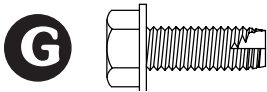

1700400 - Self-Tapping Screw - 3/8" x 1"



1700408 - Hex Nut - 1/4"



1701543 - Nylon Lock Nut - 1/4"



1700411 - Hex Nut - 5/16"



1700419 - Nylon Lock Nut - 5/16"



1700418 - Center Lock Nut - 3/8"



1700407 - Hex Nut - 3/8"

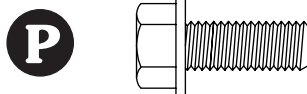

1702996 - Cap Screw - 1/2" x 1 1/4"



1700436 - Lock Washer - 1/4"

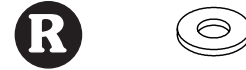

1700427 Flat Washer - 1/4"



1700434 - Lock Washer - 3/8"



1701176 - Flat Washer - 3/8"



1703373 - Flat Washer - 1/2"



1700717 - Eyebolt Anchor - 5/16"

NOTE: Wherever 3/8" x 1" self-tapping screws **G** are used with lock washers and nuts, use washers and nuts, if possible, and drill 13/32" holes. Self-tapping screws used without washers and nuts require a minimum wall thickness of 3/16". Drill 5/16" holes.

TARP INSPECTION

Tarp Length. Determine tarp length with slight tension applied. Compare actual tarp length with length stated on sheet attached to tarp. If tarp length does not match length on sheet, do not proceed. Call your local dealer or Shur-Co® Customer Service at 1-866-748-7435.

BOX PREPARATION

Prepare your box before installing your Shur-Lok® tarping system. Remove or grind any sharp edges smooth to prevent tarp damage. Fabricate additional framework if top rails have gaps that cannot be repaired.

To prevent rust, paint all exposed metal, such as weld seams and/or metal exposed by grinding or cutting, with corrosion-resistant paint.

CAUTION
 Box extensions (tip tops), if used, must be secured to truck box. System could blow off if box extensions are not secured to box.

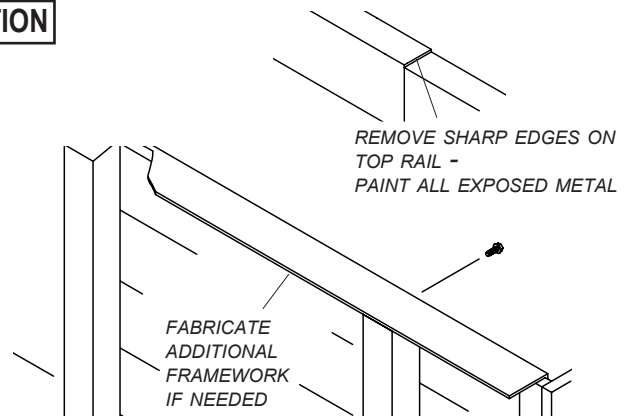

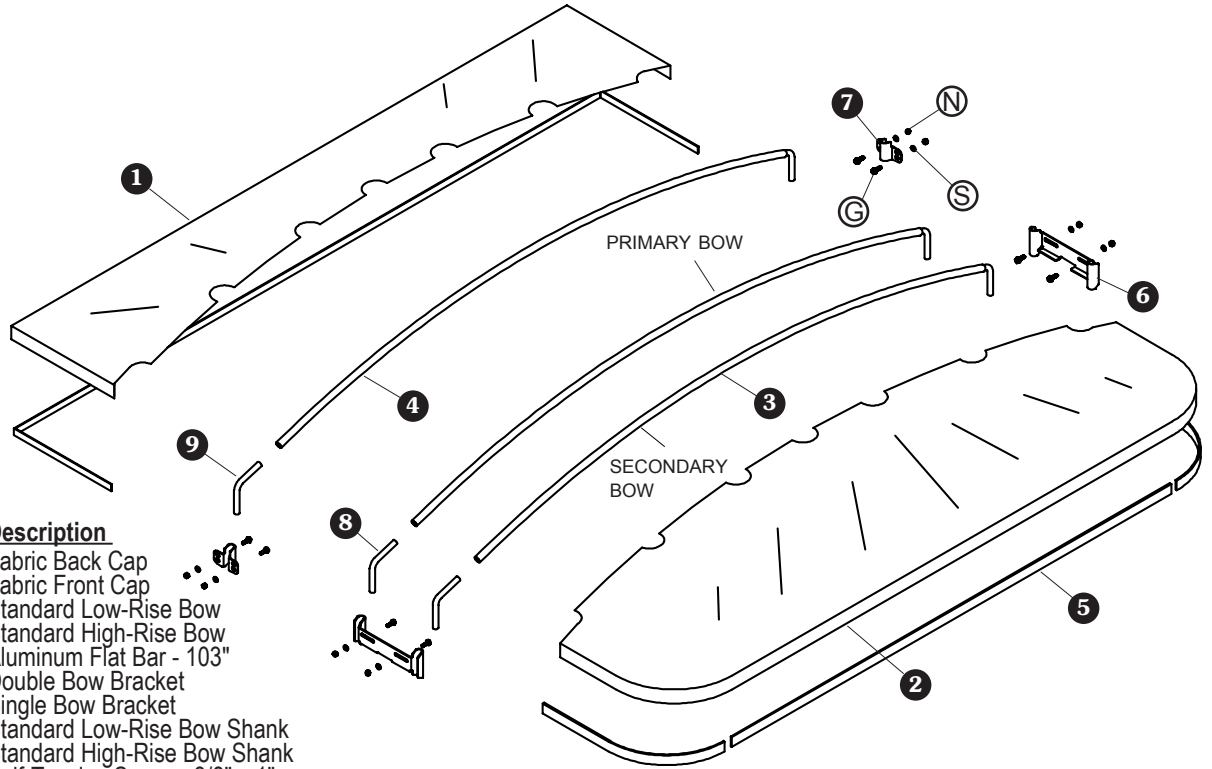

Item	Part #	Description
1.	*	Fabric Back Cap
2.	*	Fabric Front Cap
3.	1100760	Standard Low-Rise Bow
4.	1100762	Standard High-Rise Bow
5.	1700581	Aluminum Flat Bar - 103"
6.	1108211	Double Bow Bracket
7.	1120836	Single Bow Bracket
8.	1100695	Standard Low-Rise Bow Shank
9.	1106925	Standard High-Rise Bow Shank
G.	1700400	Self-Tapping Screw - 3/8" x 1"
N.	1700407	Hex Nut - 3/8"
S.	1700434	Lock Washer - 3/8"

* Specify size

STEP 1: Measuring from front of box, mark cap depth on both top rails per cap depth listed on cap tag.

NOTE: If fabric cap depth does not match cap depth listed on cap tag, do not proceed. Contact Shur-Co® for further instructions.

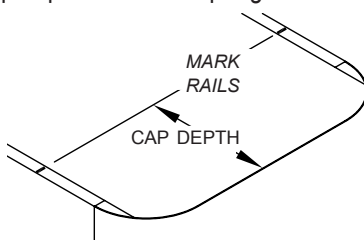

STEP 2: **1 1/2" to 3" wide rails:** Position double bow brackets with short side up.

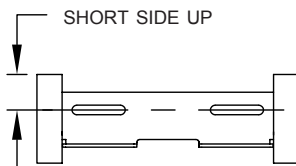

3" to 6" wide rails: Position double bow brackets with long side up.

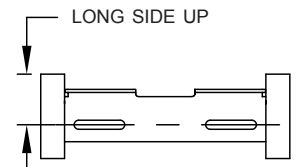

STEP 3: Position double bow brackets on rails with second mounting cavities centered on marks. Clamp brackets to rails.

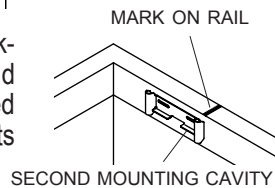

STEP 4: Place bow into double bow bracket. Place loose bow shank in opposite bow bracket.

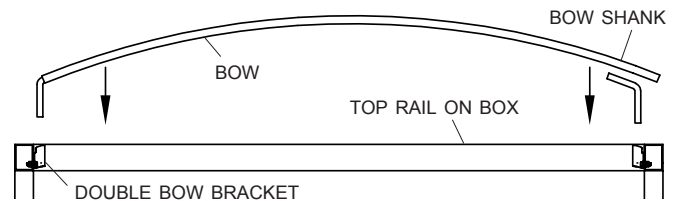

STEP 5: Align bow with bow shank. Mark bow at point where bend starts on shank. Cut both bows to this length.

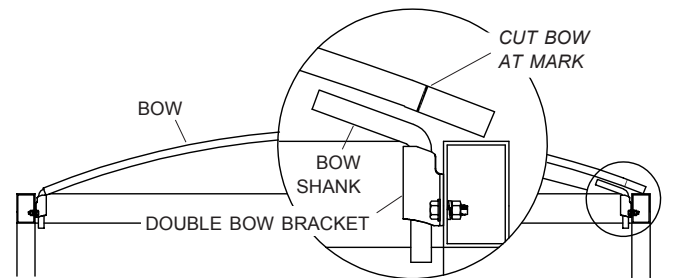

NOTE: Cut bows to exact length. Pressure from tarp will cause short bows not welded to shank to lose arch.

STEP 6: Weld bow shank into secondary bow, leaving primary bow and shank unwelded. Insert secondary bow into first mounting cavities in bow brackets and primary bow and shank into second mounting cavities.

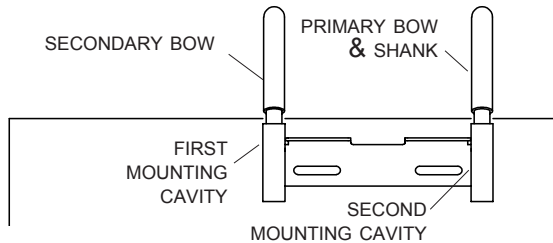

STEP 7: Adjust bow brackets vertically to achieve distance of 3" to 6" between bend in bow shank and point where tarp will contact bow.

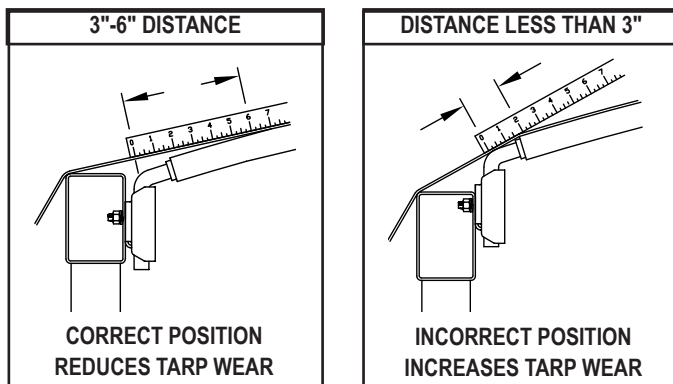

STEP 8: Mark and drill 5/16" holes. Mount brackets with screws **G**, washers **S** and nuts **N**.

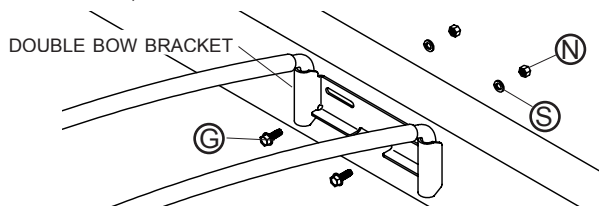

STEP 9: Remove primary bow shank from bow bracket and bow. Install fabric cap onto bow. Replace shank into bow and bow bracket. Allow front and sides of fabric cap to hang over edges of top rail on front of box.

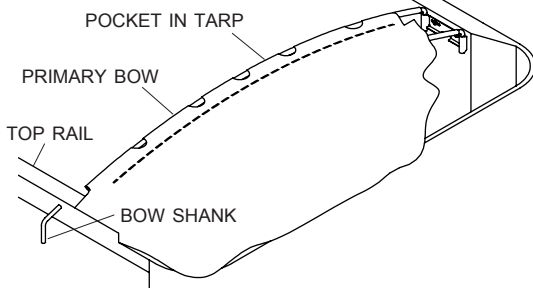

NOTE: Check fabric cap for fit on box, keeping in mind that inconsistencies in boxes may prevent a perfect fit.

STEP 10: Cut aluminum flat bar sections 1/2" shorter than pocket lengths. Insert sections into fabric cap pocket. Shape to fit corner radius, if applicable.

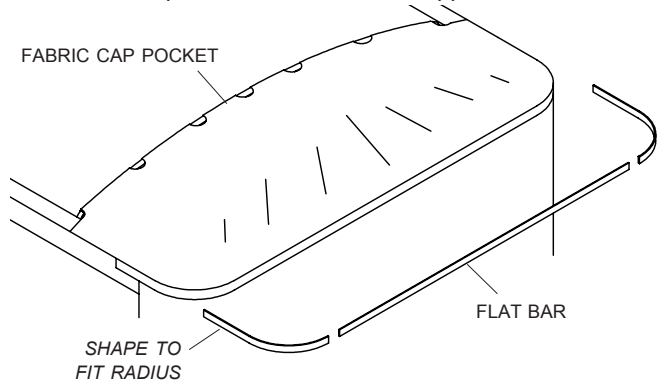

TIPS: Use one flat bar section across straight portion on front of cap. Side and radius may be one piece. Use as few pieces as possible. Create even tension on fabric cap for a secure and attractive fit.

STEP 11: Install rear bow in the same way as front bow, using single bow brackets and single bow. Do not weld loose bow shank to bow.

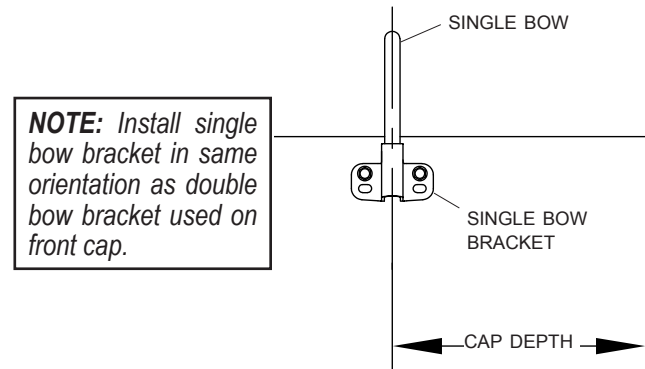

NOTE: Install single bow bracket in same orientation as double bow bracket used on front cap.

NOTE: Cut bows to exact length. Pressure from tarp will cause short bows not welded to shank to lose arch.

STEP 12: Remove rear bow shank from bow bracket and bow and slide fabric cap onto bow. Replace shank into bow and bow bracket. Install flat bar as in step 10.

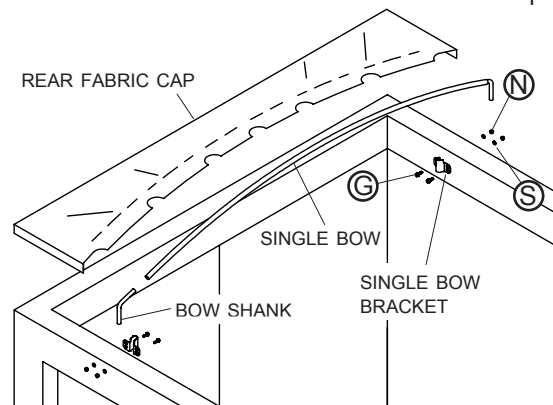

Item	Part #	Description
1.	1700990	Shock Cord - 18"
2.	1701355	Rope Anchor
F.	1701059	Self-Tapping Screw - 5/16" x 1"
G.	1700400	Self-Tapping Screw - 3/8" x 1"
L.	1700419	Nylon Lock Nut - 5/16"
N.	1700407	Hex Nut - 3/8"
S.	1700434	Lock Washer - 3/8"

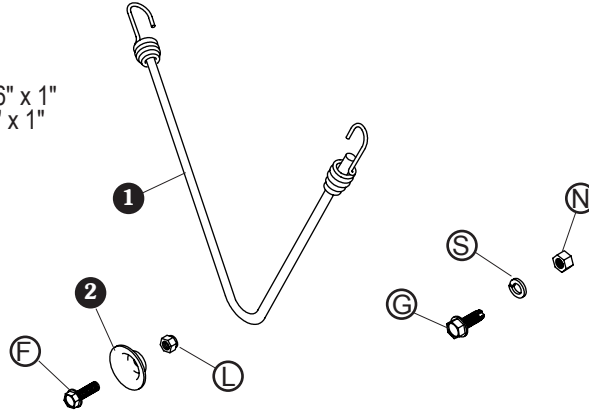

Fasten fabric caps to box with shock cords and rope anchors (to allow easy removal and replacement) or with self-tapping screws, lock washers and nuts (for permanent placement).

SHOCK CORD OPTION

STEP 1: Center shock cords on each side of cap. Drill 3/16" holes through aluminum flat bar and hook shock cords through holes.

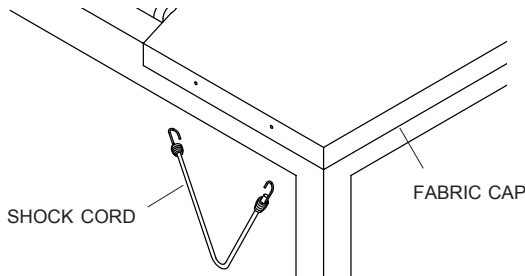

STEP 2: Equally space remaining shock cords across face of fabric cap. Drill 3/16" holes through aluminum flat bar and hook shock cords through holes.

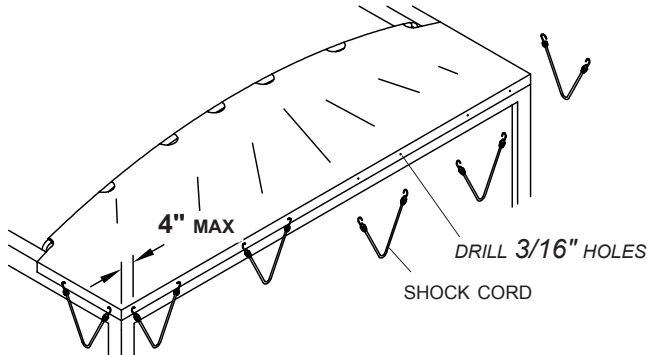

STEP 3: Locate rope anchors so shock cords receive at least 10 pounds of force pulling on them. Drill 1/4" holes and fasten rope anchors with screws F and nuts 1.

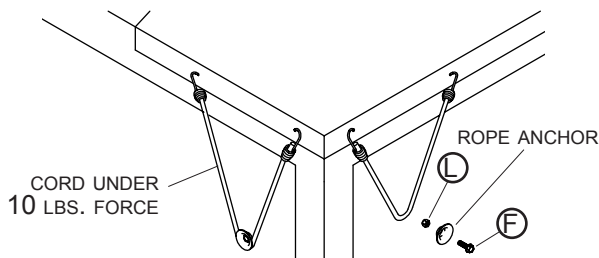

BOLT-DOWN OPTION

STEP 1: Square up fabric caps on grain cart.

STEP 2: Measure and mark a minimum of 5 hole locations across front of fabric cap, starting 6" from each side of fabric cap and equally spacing remaining holes.

STEP 3: Mark 2 hole locations on each side of fabric cap, centering holes approximately.

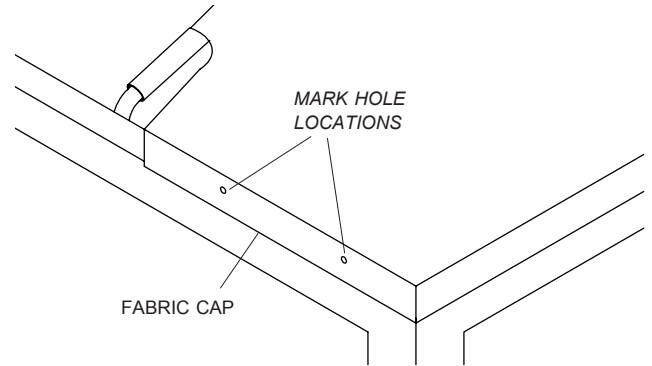

STEP 4: Drill 5/16" holes at marked locations through fabric cap, aluminum flat bar and box. Fasten cap to box with screws G, washers S and nuts N.

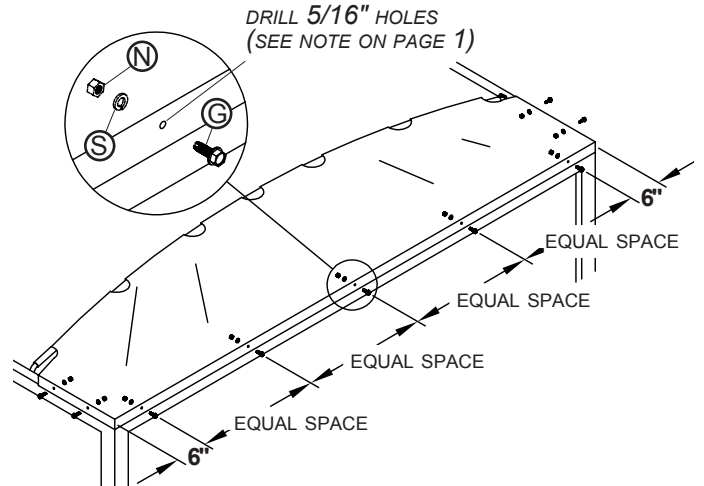

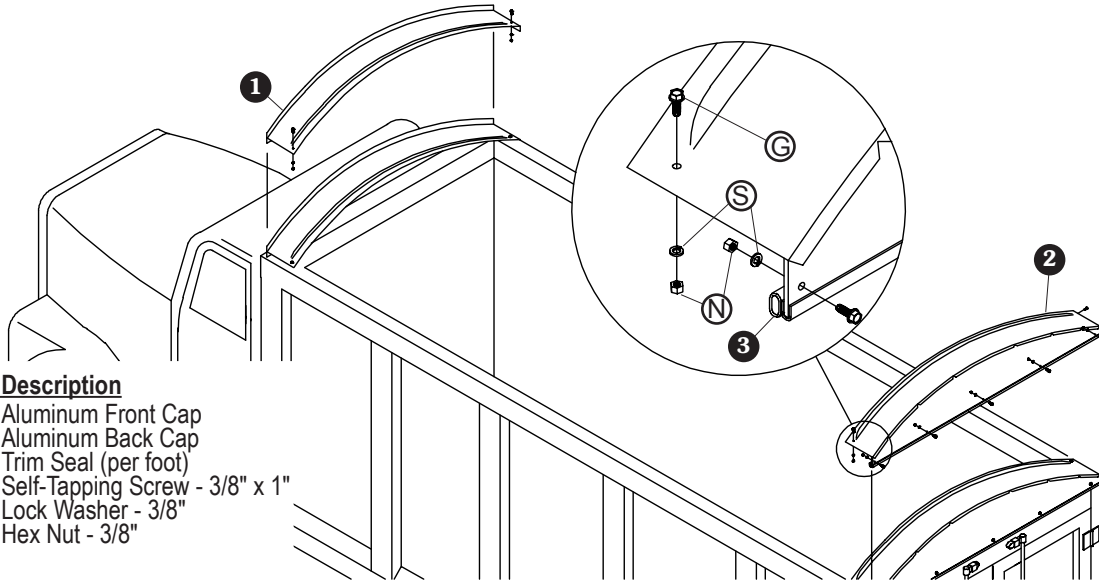

Item	Part #	Description
1.	*	Aluminum Front Cap
2.	*	Aluminum Back Cap
3.	1700152	Trim Seal (per foot)
G.	1700400	Self-Tapping Screw - 3/8" x 1"
S.	1700434	Lock Washer - 3/8"
N.	1700407	Hex Nut - 3/8"

* Specify size

STEP 1: **Modify caps to fit.** Place front cap with windshield on front of box. Place rear cap on rear of box. Modify caps to fit your box, if required.

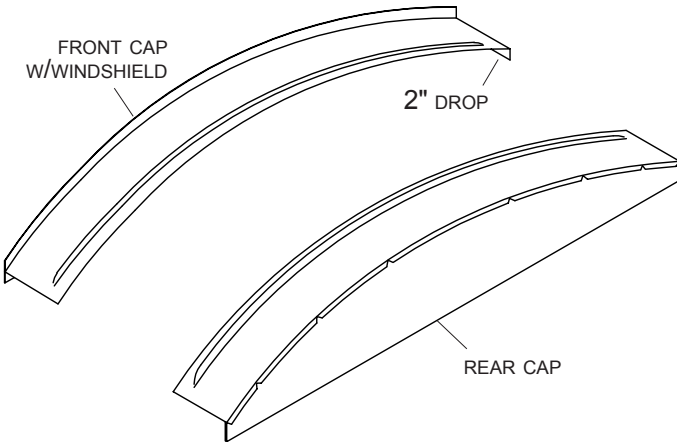

NOTE: To install tarp to open from passenger side of trailer (reverse roll), remove 2" cap drop on passenger side before installing caps.

STEP 2: **Trim seal.** Apply trim seal to caps, placing foam seal on inside of caps. Tap into place.

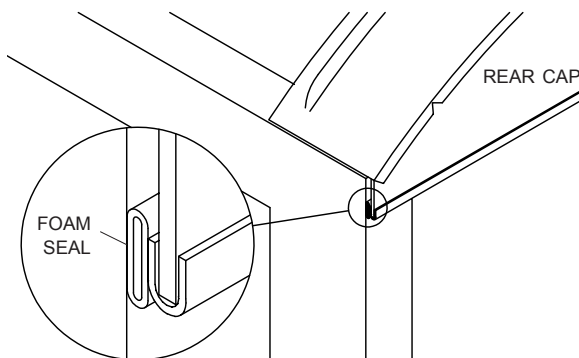

STEP 3: Evenly space 5 screws across face of cap. Mark and drill 5/16" holes and fasten with screws (G). Use washer (S) and nut (N) where possible.

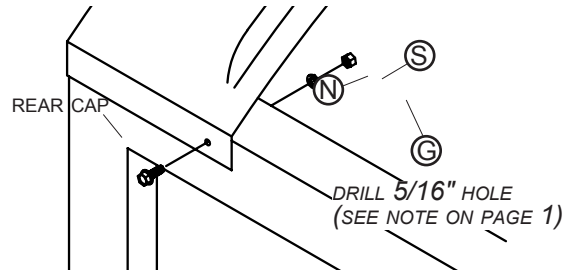

STEP 4: **Install caps.** Drill 5/16" hole near truss tube on cap drop and fasten with screw (G). Use washer (S) and nut (N) where possible.

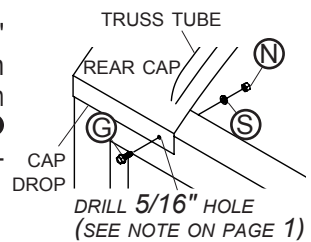

NOTE: For optimal water run-off and tarp support, make sure end caps are level before fastening sides of caps to box. While fastening sides of caps to box, raise center of truss tube edge of cap to be level with or slightly higher than outside edge.

STEP 5: Drill 5/16" hole as close as possible to truss tube on driver side of cap. Fasten with screw (G). Use washer (S) and nut (N) where possible.

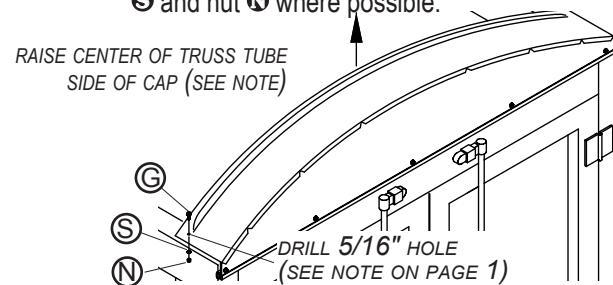

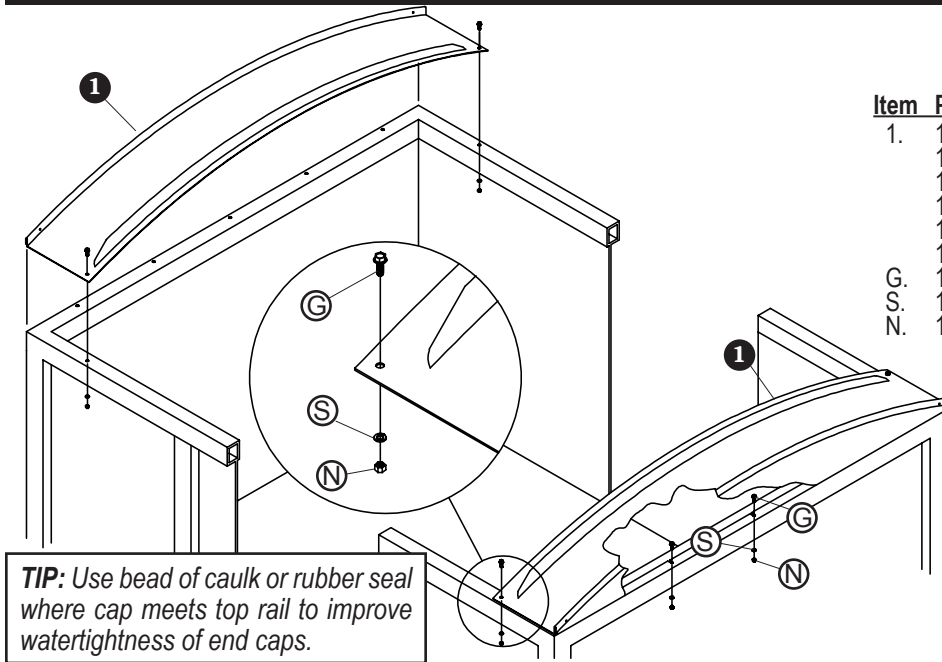

Item	Part #	Description
1.	1108977	Galv. Low-Rise - 94" to 95" Box
	1108980	Galv. Low-Rise - 96" to 97" Box
	1108983	Galv. Low-Rise - 101" to 102" Box
	1108986	Galv. High-Rise - 94" to 95" Box
	1108989	Galv. High-Rise - 96" to 97" Box
	1108992	Galv. High-Rise - 101" to 102" Box
G.	1700400	Self-Tapping Screw - 3/8" x 1"
S.	1700434	Lock Washer - 3/8"
N.	1700407	Hex Nut - 3/8"

TIP: Use bead of caulk or rubber seal where cap meets top rail to improve watertightness of end caps.

NOTE: End caps may need slight modifications to fit your box.

STEP 1: Center end caps on box. Mark hole locations on top rail using slots in cap as guide.

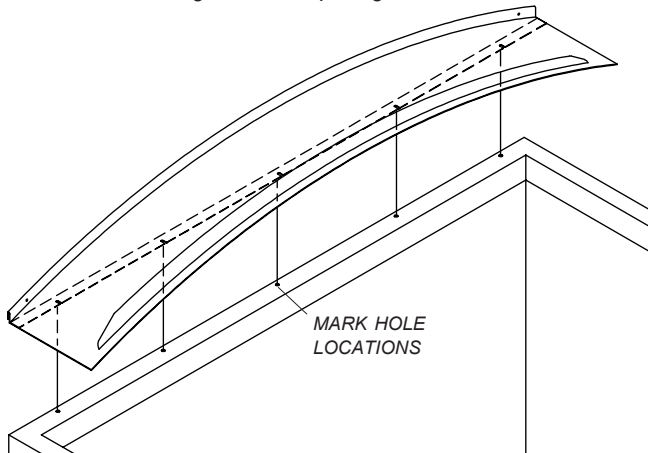

STEP 2: Drill 5/16" holes at marked locations on top rail. Fasten end cap to rail with screws G. Use washers S and nuts N where possible.

TIP: Thread 3/8" x 1" self-tapping screws into top rail, back screws partially out, slide cap into place and tighten screws.

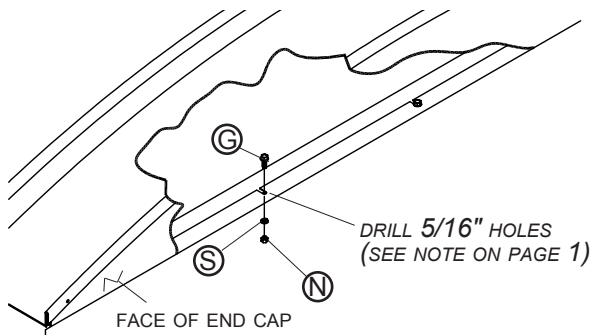

NOTE: For optimal water run-off and tarp support, make sure end caps are level before fastening sides of caps to box. While fastening sides of caps to box, raise center of truss tube side of cap to be level with or slightly higher than outside edge.

STEP 3: Drill 2 5/16" holes as close as possible to truss tube, through end cap and top rail.

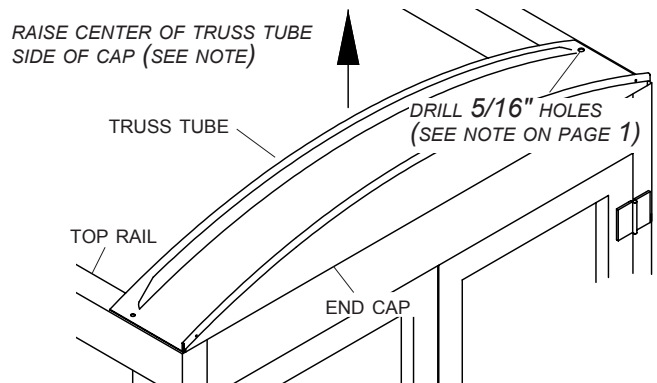

STEP 4: Fasten with screws G. Use washers S and nuts N where possible.

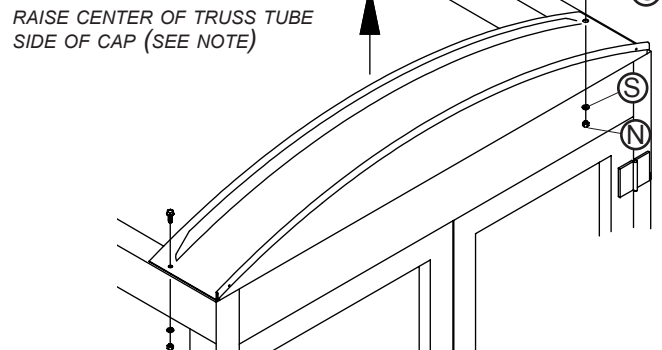

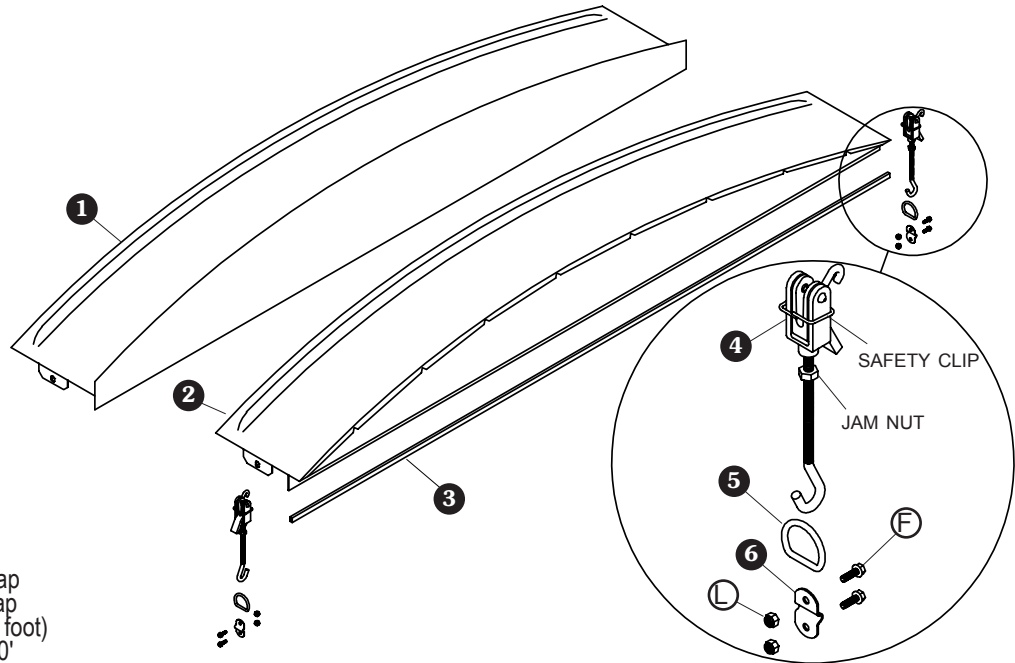

Item	Part #	Description
1.	*	Easy-Off Front Cap
2.	*	Easy-Off Back Cap
3.	1701115	Rubber Seal (per foot)
	1101865	Rubber Seal - 100'
4.	1701113	Over-Center Clamp/Safety Clip
5.	1701218	D-Ring - 1 1/2"
6.	1701114	D-Ring Plate
F.	1701059	Self-Tapping Screw - 5/16" x 1"
L.	1700419	Nylon Lock Nut - 5/16"

* Specify size

CAUTION
Secure safety clips around clamps before driving vehicle.

STEP 1: Deburr rough edges on truck and clean area thoroughly before applying rubber seal.

STEP 2: Apply rubber seal to front cap.

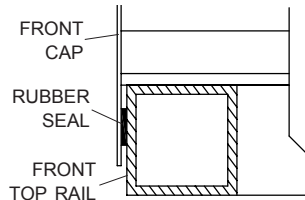

STEP 3: Place front cap on box.

NOTE: Do not apply rubber seal in temperatures below 60°F or above 100°F or adhesive may fail. Apply seal without stretching.

STEP 4: Locate clamps in area free from obstructions and offset D-ring 1/2" from center of cap.

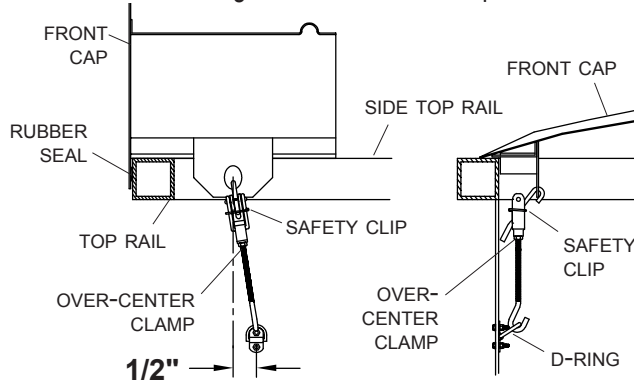

STEP 5: Mark and drill 1/4" holes. Fasten D-ring plates to box with screws (F) and nuts (L). Tighten jam nut against clamp body and position safety clip.

STEP 6: Place rear cap on box. Notch inside drop to allow 1/8" clearance on both sides of top rail.

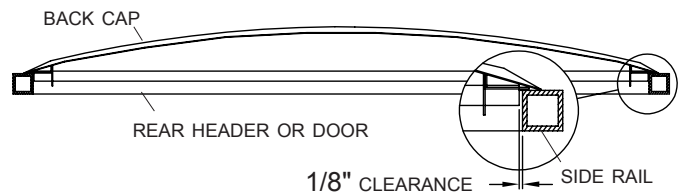

STEP 7: Remove cap, apply rubber seal 1/4" down from flat portion of cap above drop.

STEP 8: Replace cap, locate over-center clamps in area free from obstructions and offset D-ring 1/2" from center of cap.

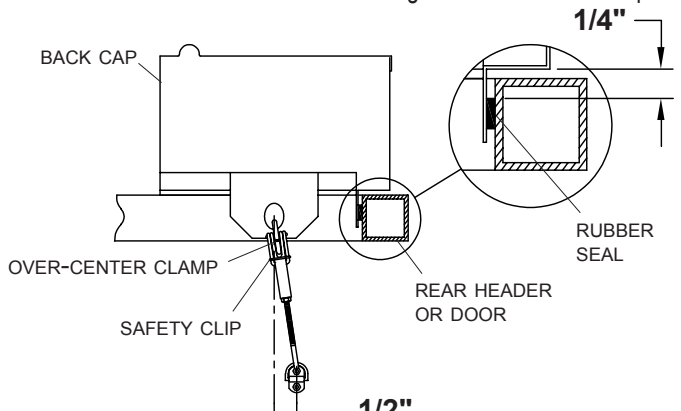

STEP 9: Mark and drill 1/4" holes. Fasten D-ring plate to box with screws (F) and nuts (L). Tighten jam nut against clamp body and position safety clip.

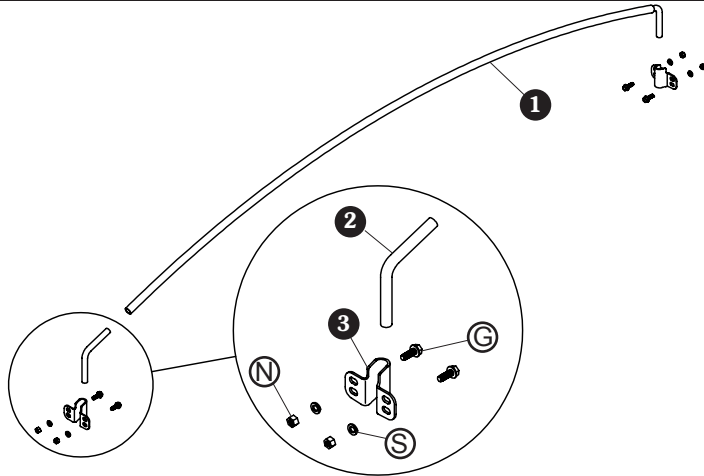

Item	Part #	Description
1.	1117904	Std. Low Rise Bow - 78" to 84"
	1116120	Std. Low Rise Bow - 85" to 92"
	1100760	Std. Low Rise Bow - 93" to 102"
	1117905	Std. High Rise Bow - 89" to 95"
	1100762	Std. High Rise Bow - 96" to 102"
	1109149	Std. Flat Bow - 89" to 102"
2.	1100695	Std. Low Rise Bow Shank
	1106925	Std. High Rise Bow Shank
	1109150	Std. Flat Bow Shank
3.	1120836	Single Bow Bracket
G.	1700400	Self-Tapping Screw - 3/8" x 1"
N.	1700407	Hex Nut - 3/8"
S.	1700434	Lock Washer - 3/8"

STEP 1: Mark bow bracket locations on top rails between end caps as shown.

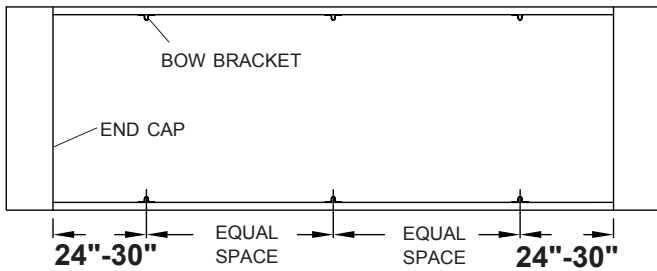

STEP 2: 1 1/2" to 3" wide rails. Position single bow brackets with long side up and fasten through upper holes.

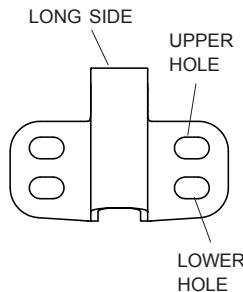

3" to 6" wide rails. Position single bow brackets with long side up and fasten through lower holes.

STEP 3: Align center of brackets with mark. Clamp brackets to rails.

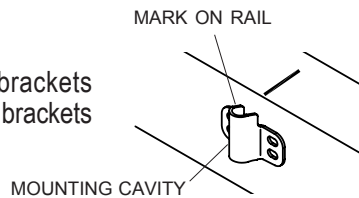

STEP 4: Place bow into bow bracket. Place loose bow shank in opposite bow bracket.

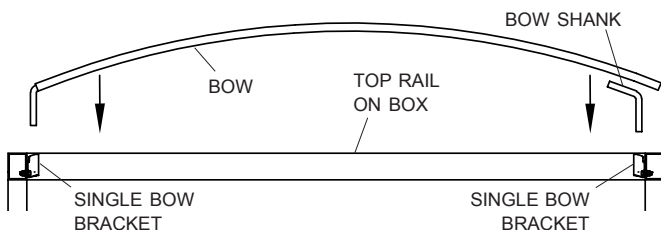

STEP 5: Align bow with bow shank. Mark and cut bow at point where bend starts on shank. Grind edges smooth and weld shank to bow.

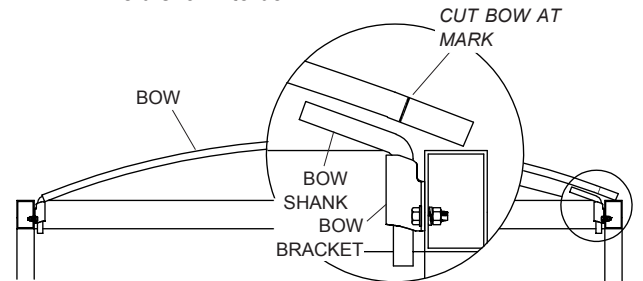

NOTE: Shanks must be welded to bows.

STEP 6: Adjust bow brackets vertically to create a distance of 3" to 6" between bend in bow shank and point where tarp will contact bow.

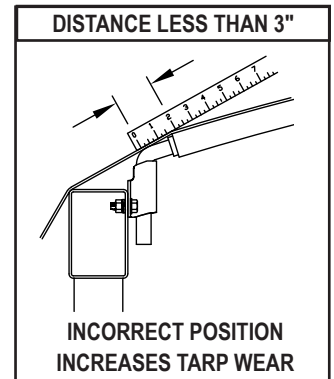
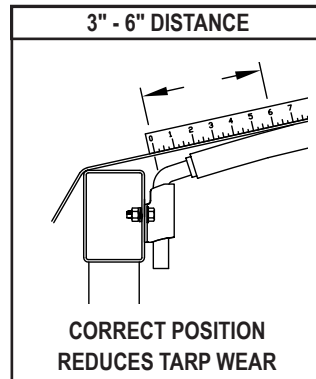

STEP 7: Mark and drill 5/16" holes. Mount brackets with screws G, washers S and nuts N. Install bows into bow brackets.

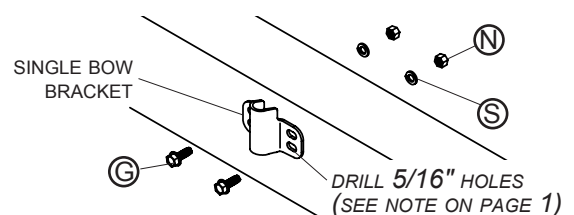

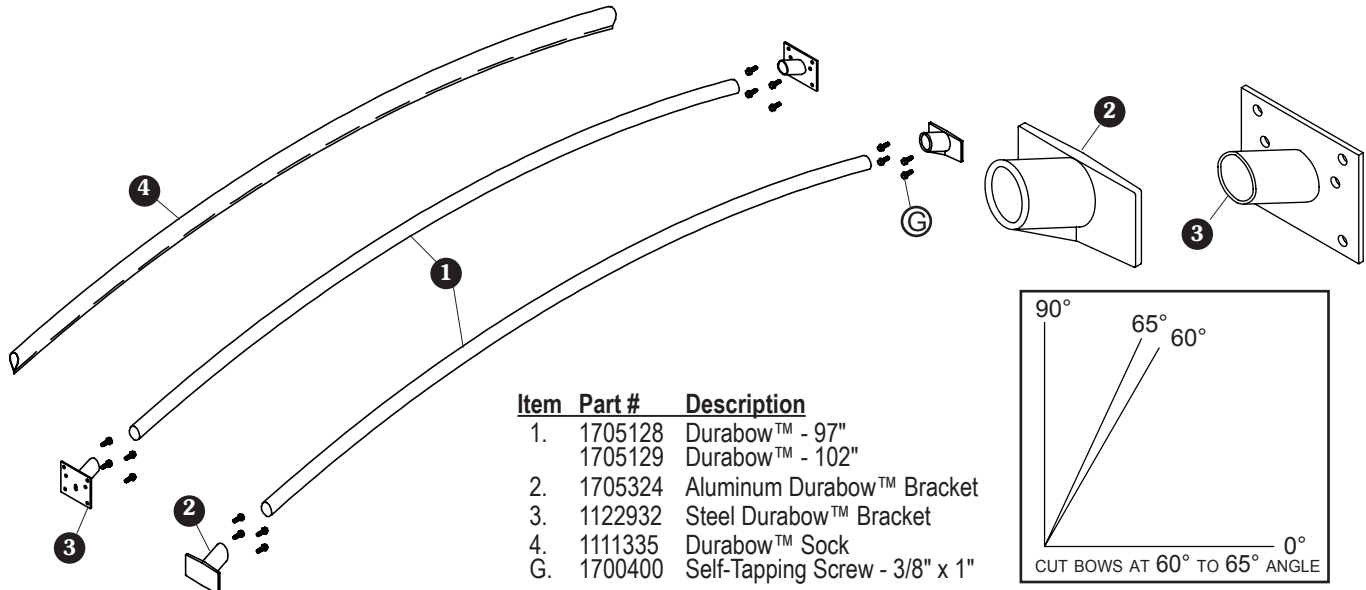

STEP 1: Space bow brackets as shown, aligning brackets on opposite sides of box.

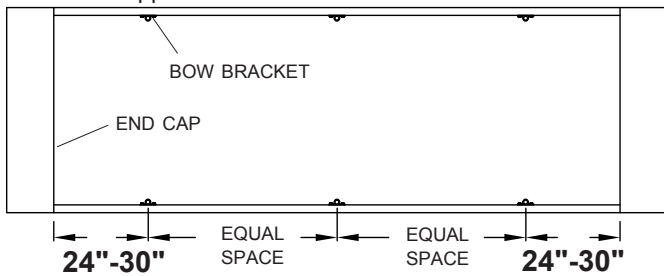

NOTE: Warranty will be void if bow ends are not cut at 60° to 65° angle.

NOTE: To maintain consistent 10" to 12" bow arch, it is important to measure trailer width at each bow location because widths may vary from front to back.

STEP 2: Align bow brackets flush with top rail. Mark and drill 5/16" holes and secure brackets with screws G.

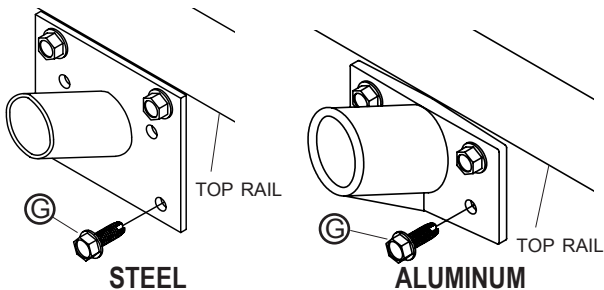

STEP 4: Slide bow sock over Flexbow® and trim to fit.

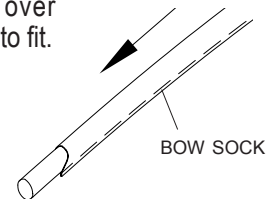

STEP 5: Insert bows into brackets.

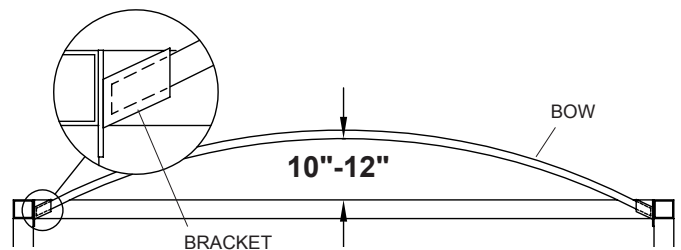

STEP 2: Cut bow ends at 60° to 65° angle. Cut short side of bows 2" longer than inside trailer width to obtain 10" to 12" arch.

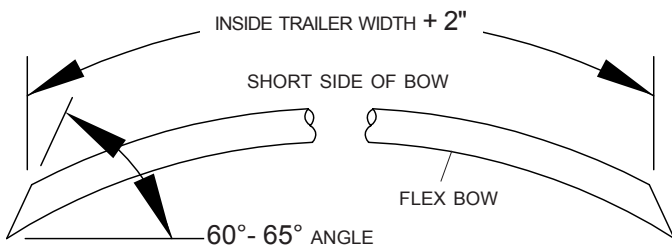

CAUTION
Stay clear of top side of bow. Bows could release and spring upward.

Example: If trailer width is 90" inside to inside, cut short side of bow 92" long.

NOTE: Brackets may be welded instead of bolted into place. Consult trailer manufacturer for recommended welding procedure.

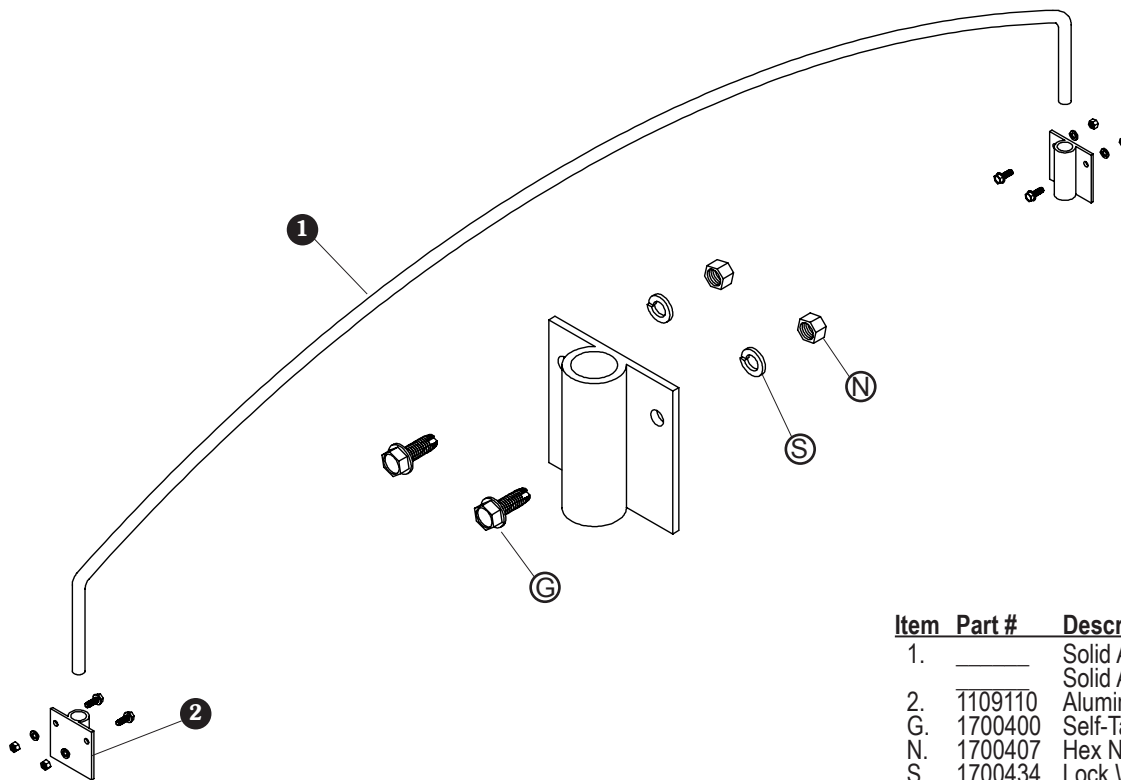

Item	Part #	Description
1.		Solid Aluminum Low Rise Bow Solid Aluminum High Rise Bow
2.	1109110	Aluminum Bow Bracket
G.	1700400	Self-Tapping Screw - 3/8" x 1"
N.	1700407	Hex Nut - 3/8"
S.	1700434	Lock Washer - 3/8"

STEP 1: Equally space bow brackets on box, aligning brackets straight across trailer.

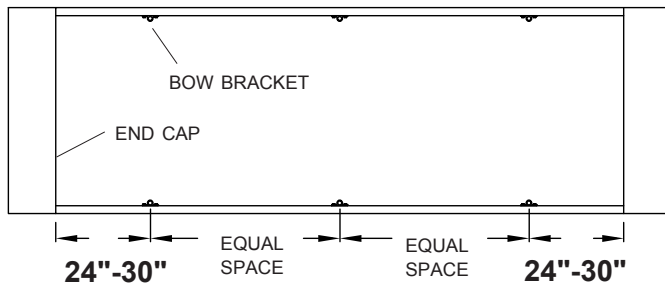

STEP 2: Align top edge of brackets with top edge of rail. Mark and drill 5/16" holes. Secure brackets with screws G, washers S and nuts N.

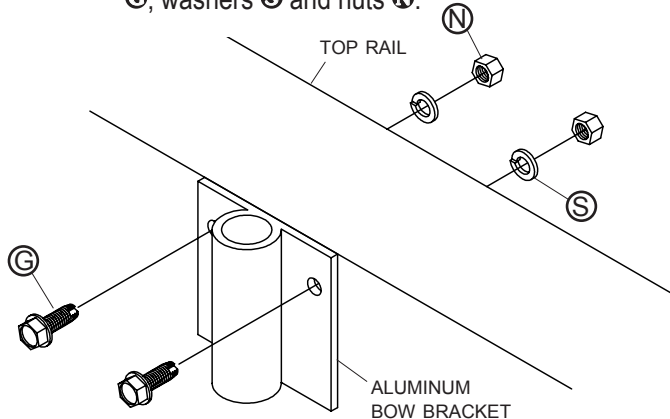

STEP 3: Insert bows into bow brackets.

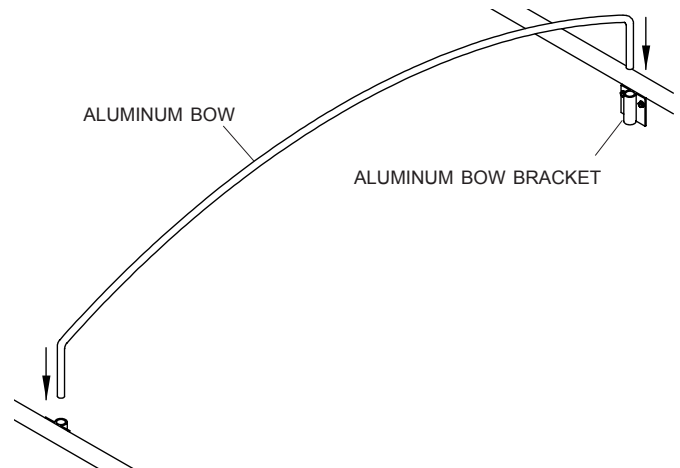

NOTE: Be sure of exact inside box width when ordering solid aluminum bows. Bows cannot be cut to length. Bow width may vary from front to back.

Item	Part #	Description
1.	1112669	Heavy-Duty Flat Bow
	1106612	Heavy-Duty Low Rise Bow
	1101927	Heavy-Duty High Rise Bow
2.	1104706	Heavy-Duty Bow Shank
3.	1106614	Heavy-Duty Bow Bracket
4.	1701098	Lynch Pin
5.	1104123	Heavy-Duty Bow Pin
G.	1700400	Self-Tapping Screw - 3/8" x 1"
N.	1700407	Hex Nut - 3/8"
S.	1700434	Lock Washer - 3/8"

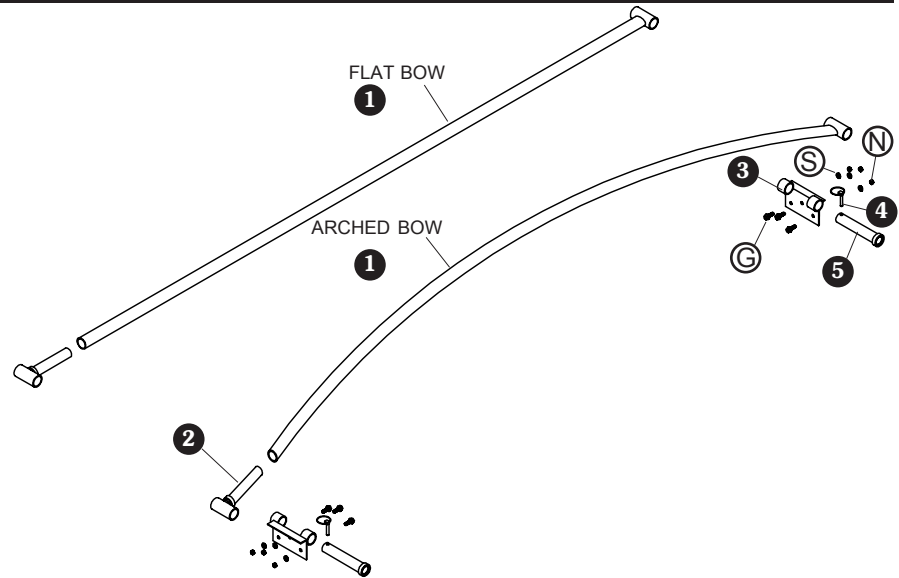

STEP 1A: End dumps and belly dumps. Equally space bow brackets on box, aligning brackets on opposite sides.

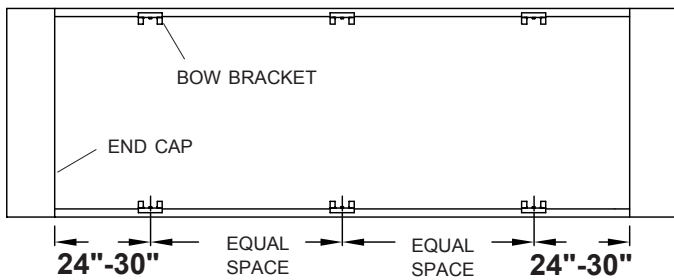

STEP 1B: Dump bodies. Locate front bow brackets 8" behind any obstruction, such as cab shield, dog house or plank gussets. Equally space remaining bow brackets on box, aligning brackets on opposite sides.

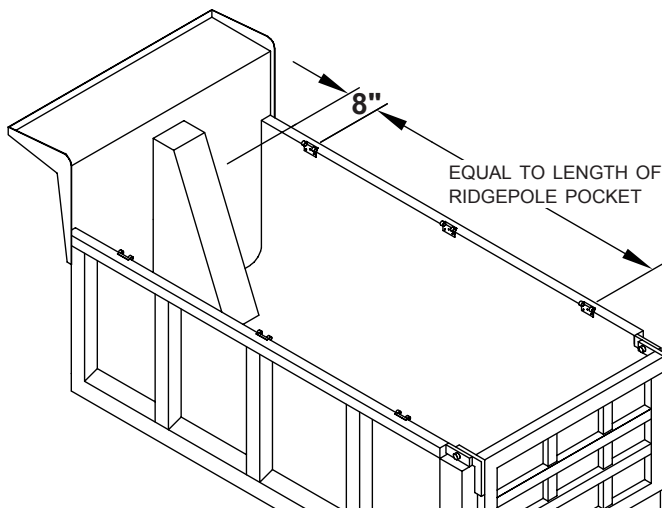

NOTE: If kit uses ridgepole, measure length of ridgepole pocket on tarp. Distance between front and rear bow brackets should be equal to length of ridgepole pocket.

STEP 2: Mark and drill 5/16" holes. Secure brackets with screws G, washers S and nuts N.

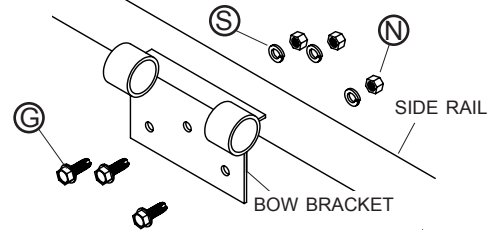

STEP 3: Insert bow shank into driver side bow bracket and align bow with passenger side bow bracket. Align bow with bow shank and mark point where bow meets stop ring. Remove and cut bow at marked location. Grind edges smooth and insert bow shank into bow. Do not weld shank to bow.

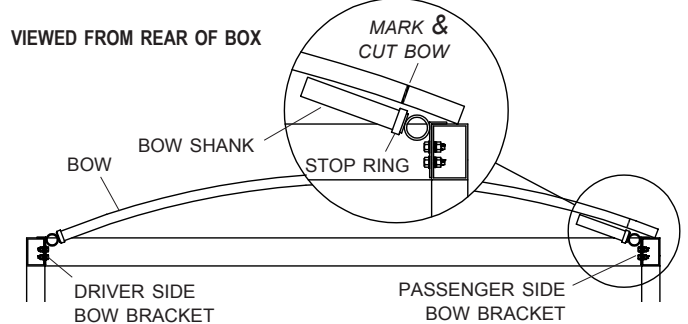

STEP 4: Fasten bow into bow brackets with bow pins. Secure with lynch pins.

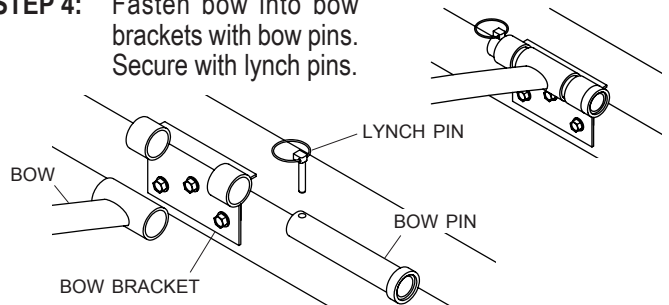

NOTE: For galvanized steel or aluminum cap applications, fasten ridge strap(s) to end caps. For fabric cap applications, fasten ridge strap(s) to top rail.

Item	Part #	Description
1.	1101680	Ridge Strap w/Anchor - 1" x 25'
	1101681	Ridge Strap w/Anchor - 1" x 39'
	1101682	Ridge Strap w/Anchor - 1" x 46'
	1107066	Ridge Strap w/Anchor - 1" x 56'
2.	1101678	Ratchet w/1" Ridge Strap/Anchor
3.	1700836	Ratchet - 1" Web
4.	1101683	Anchor Bushing
G.	1700400	Self-Tapping Screw - 3/8" x 1"
T.	1701176	Flat Washer - 3/8"
M.	1700418	Centerlock Nut - 3/8"

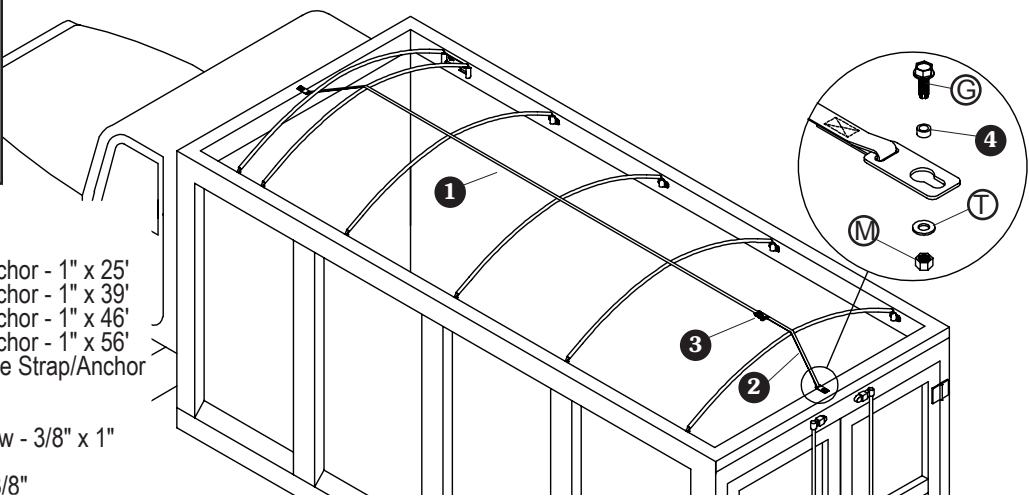

STEP 1: Mark hole locations at center of front and rear caps (mark top rails for fabric caps).

BOXES UP TO 8 1/2' WIDE

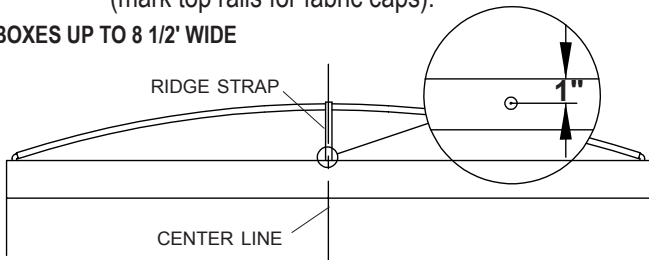

BOXES OVER 8 1/2' WIDE

Mark hole locations 20" apart on front and rear caps (mark top rails for fabric caps).

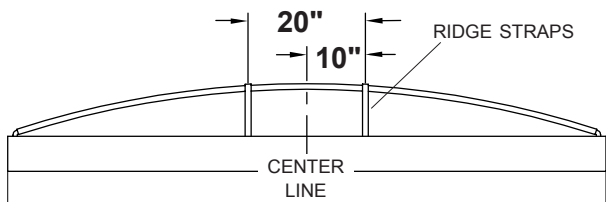

STEP 2: Drill holes and fasten ridge strap anchor bushings with screws G, washers T and nuts M.

NOTE: Use washers and nuts where needed and drill 13/32" holes. If using self-tapping screws only, drill 5/16" holes.

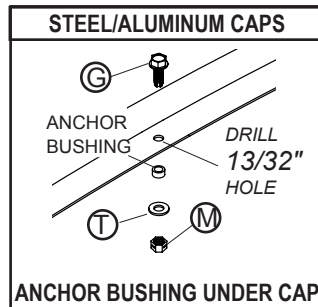
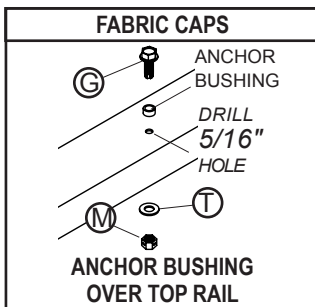

STEP 3: Install ridge straps over bows, positioning ratchet below strap as shown. Position ridge strap under first bow for front fabric cap.

STEEL OR ALUMINUM CAPS

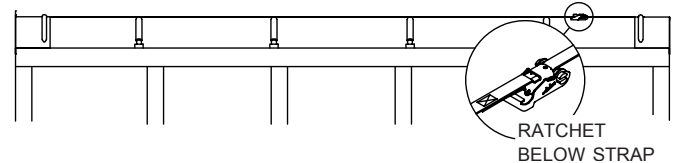

FABRIC CAPS

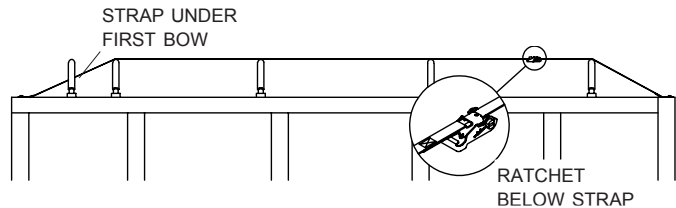

STEP 4: Hook ridge strap anchors onto anchor bushings on front and rear end caps (top rails).

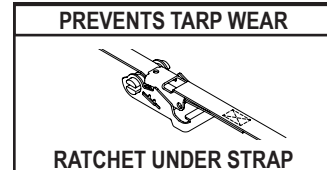
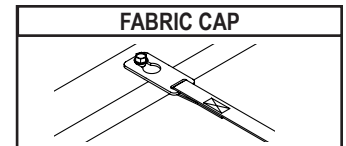
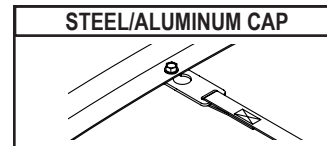

STEP 5: Thread strap through ratchet and tighten.

NOTE: Keep ridge straps tight for adequate tarp support. Check tension regularly.

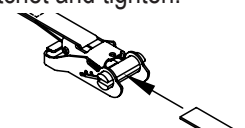

NOTE: For galvanized steel or aluminum cap applications, fasten ridge strap(s) to end caps. For fabric cap applications, fasten ridge strap(s) to top rail.

Item	Part #	Description
1.	1100571	Ridge Strap w/Anchor - 2" x 25'
	1100579	Ridge Strap w/Anchor - 2" x 39'
	1100580	Ridge Strap w/Anchor - 2" x 46'
	1107067	Ridge Strap w/Anchor - 2" x 56'
2.	1100594	Ratchet w/2" Ridge Strap
G.	1700400	Self-Tapping Screw - 3/8" x 1"
S.	1700434	Lock Washer - 3/8"
N.	1700407	Hex Nut - 3/8"

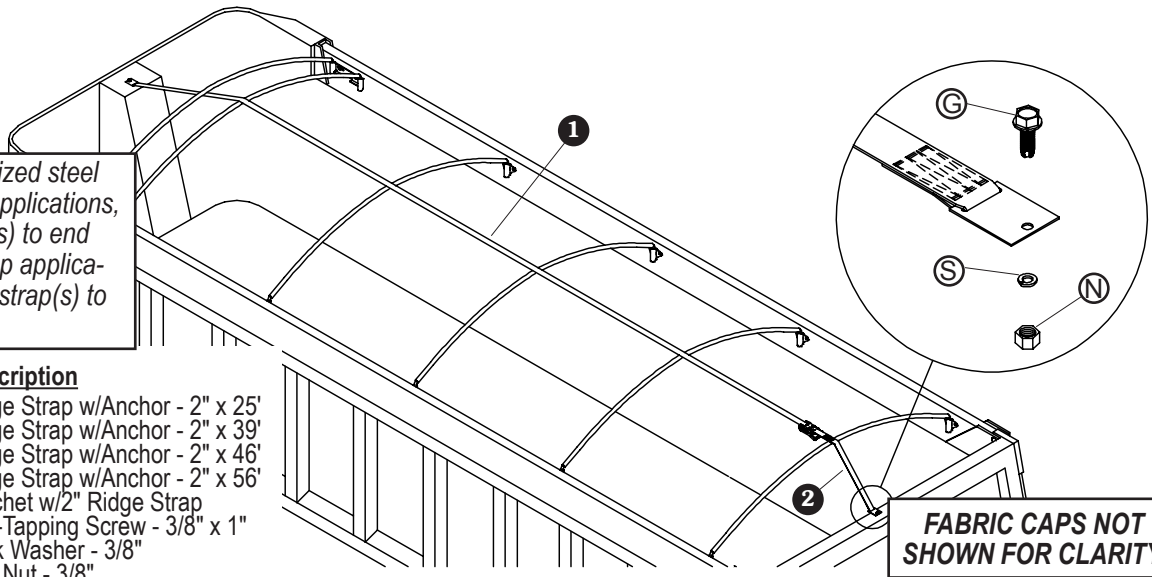

FABRIC CAPS NOT SHOWN FOR CLARITY.

STEP 1: Mark hole locations at center of front and rear caps (mark top rails for fabric caps).

BOXES UP TO 8 1/2' WIDE

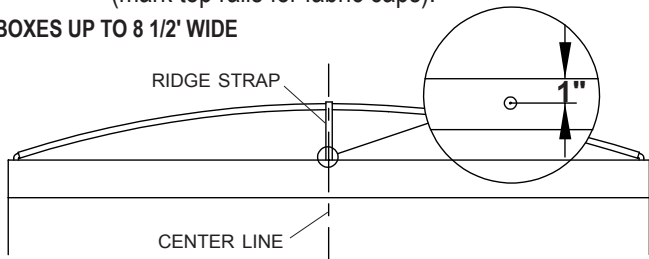

BOXES OVER 8 1/2' WIDE

Mark hole locations 20" apart on front and rear caps (mark top rails for fabric caps).

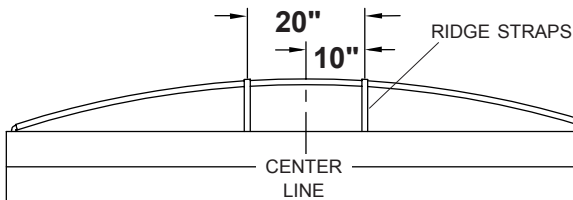

STEP 2: Place ridge straps over bows, positioning ratchet below strap as shown. Position ridge strap under first bow for front fabric cap.

STEEL OR ALUMINUM CAPS

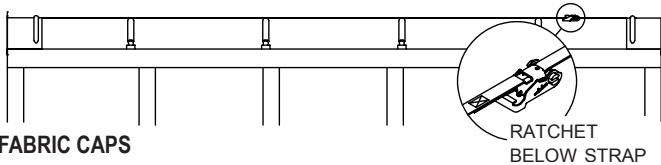

FABRIC CAPS

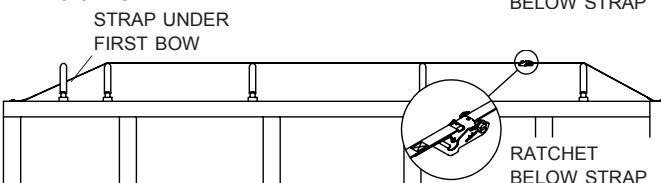

STEP 3: Drill holes and fasten ridge strap anchors with screws G, washers S and nuts N.

NOTE: Use washers and nuts where needed and drill 13/32" holes. If using self-tapping screws only, drill 5/16" holes.

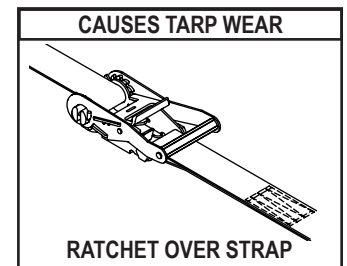
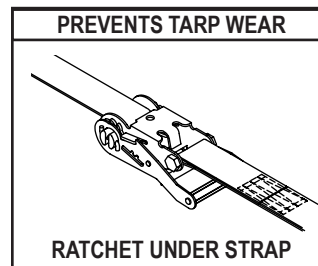
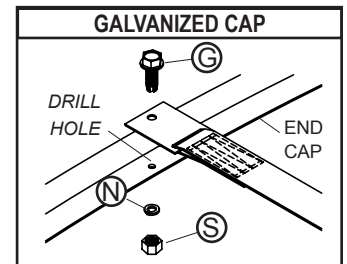
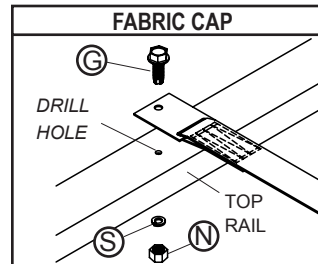

STEP 4: Thread strap through ratchet and tighten.

NOTE: Keep ridge straps tight for adequate tarp support. Check tension regularly.

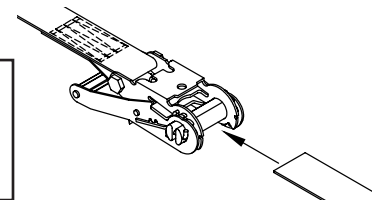

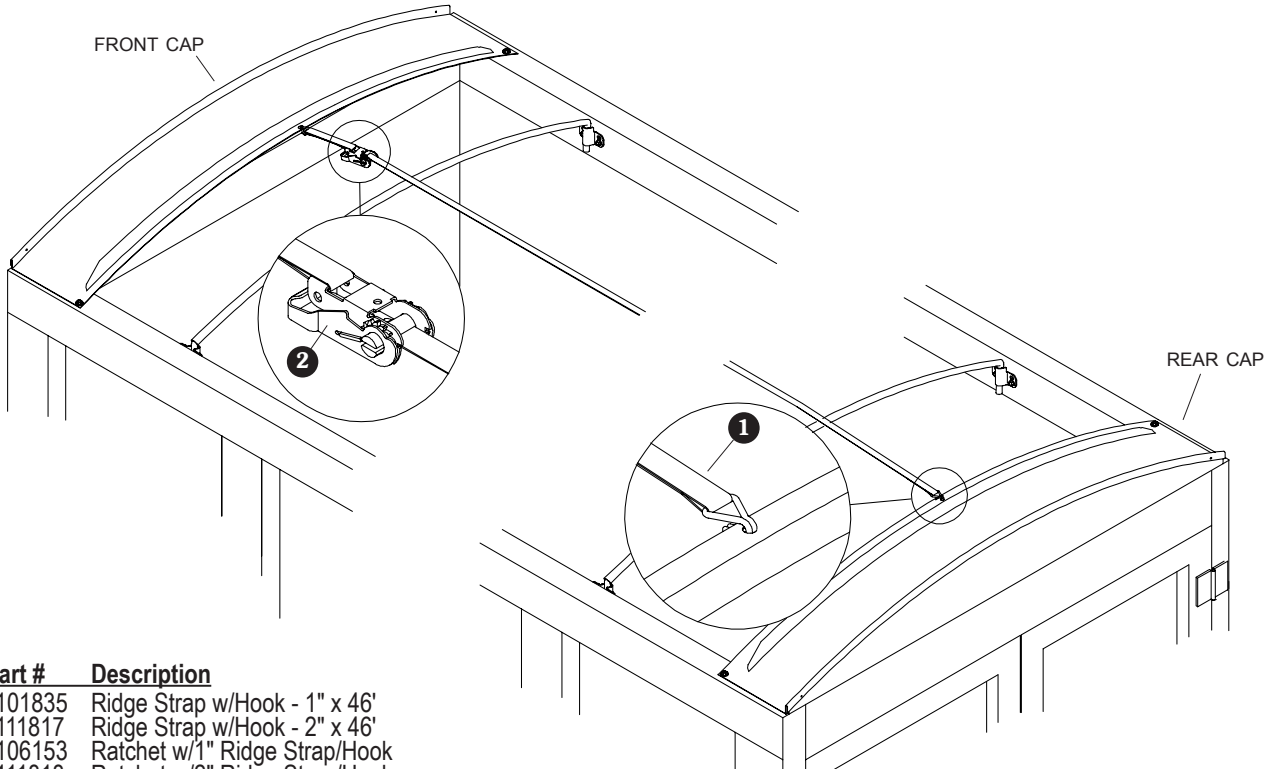

Item	Part #	Description
1.	1101835	Ridge Strap w/Hook - 1" x 46'
	1111817	Ridge Strap w/Hook - 2" x 46'
2.	1106153	Ratchet w/1" Ridge Strap/Hook
	1111818	Ratchet w/2" Ridge Strap/Hook

STEP 1: Mark hole locations at center of front and rear caps.

BOXES UP TO 8 1/2' WIDE

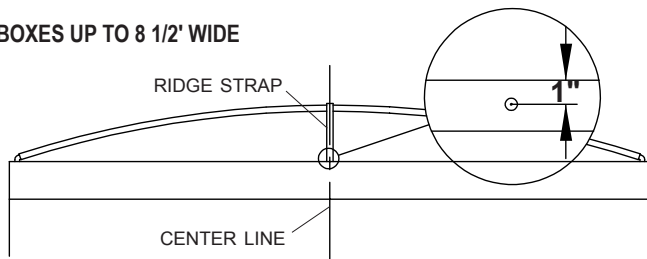

BOXES OVER 8 1/2' WIDE

Mark hole locations 20" apart on front and rear caps.

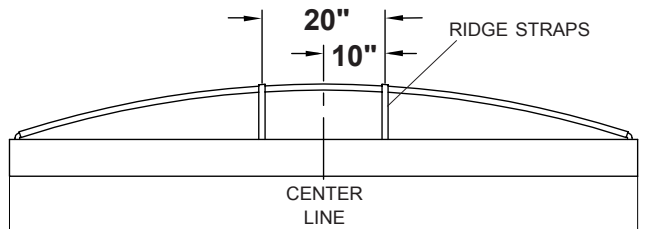

STEP 2: Place ridge straps over bows, positioning ratchet below strap as shown.

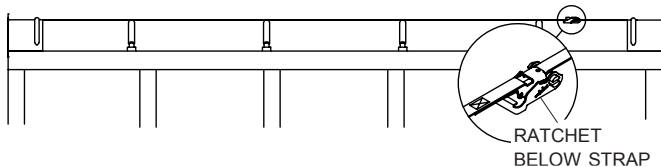

STEP 3: Drill 7/16" holes at marked locations. Hook ridge strap and ratchet strap into holes on end caps. Position ratchet under strap to prevent tarp wear.

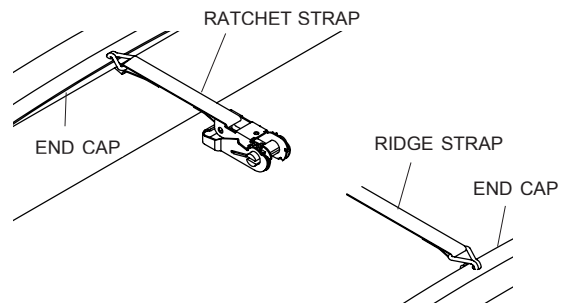

STEP 4: Thread strap through ratchet and tighten.

NOTE: Keep ridge straps tight for adequate tarp support. Check tension regularly.

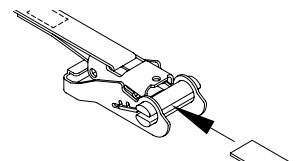

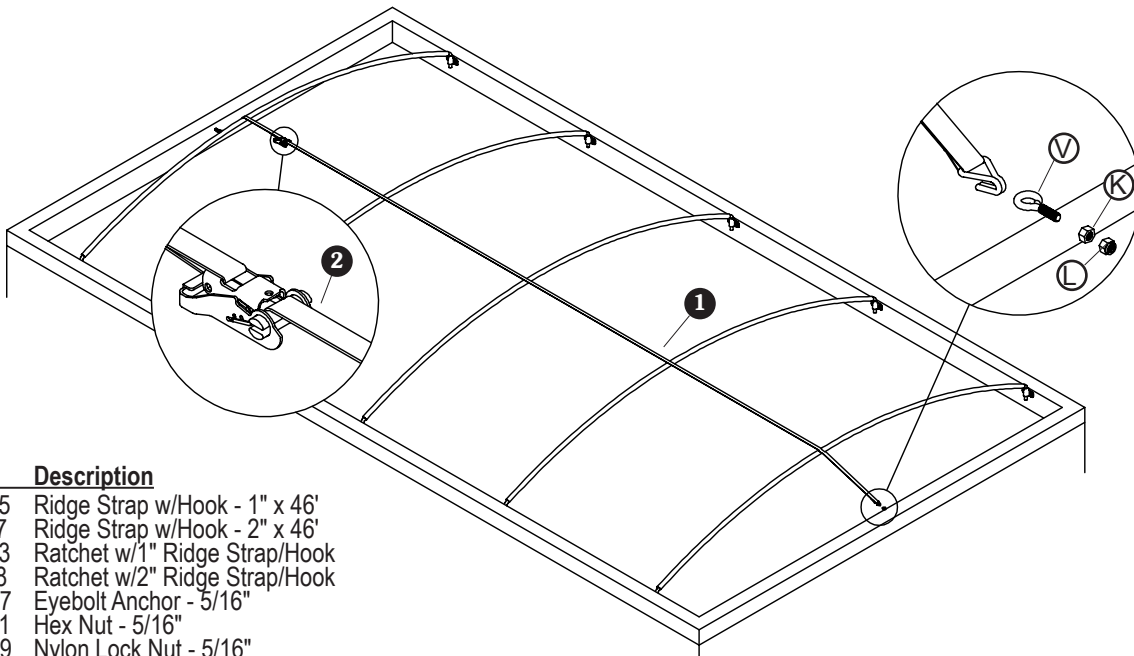

Item	Part #	Description
1.	1101835	Ridge Strap w/Hook - 1" x 46'
	1111817	Ridge Strap w/Hook - 2" x 46'
2.	1106153	Ratchet w/1" Ridge Strap/Hook
	1111818	Ratchet w/2" Ridge Strap/Hook
V.	1700717	Eyebolt Anchor - 5/16"
K.	1700411	Hex Nut - 5/16"
L.	1700419	Nylon Lock Nut - 5/16"

STEP 1: Mark hole locations at center of front and rear caps.
BOXES UP TO 8 1/2' WIDE

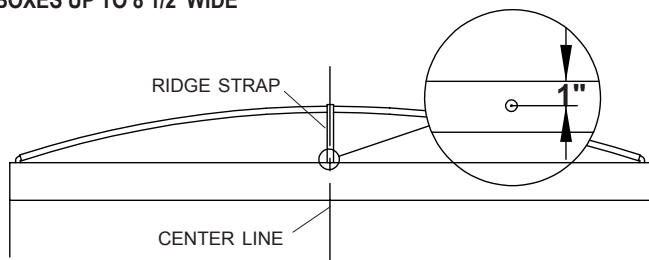

BOXES OVER 8 1/2' WIDE
Mark hole locations 20" apart on front and rear caps.

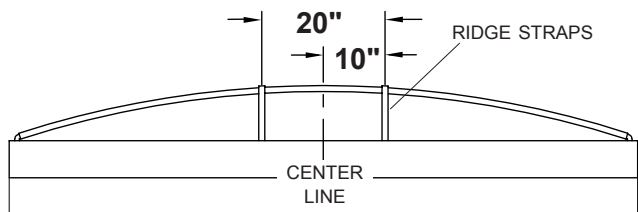

STEP 2: Place ridge straps over bows, positioning ratchet below strap as shown. Position ridge strap under first bow for front fabric cap.

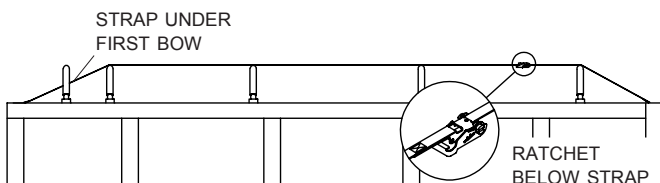

STEP 3: Mark and drill 5/16" holes at marked locations. Fasten eyebolt anchors (V) through holes with nuts (K) and lock nuts (L).

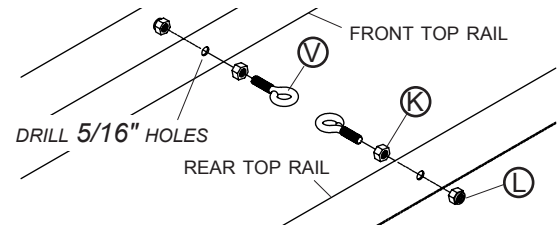

STEP 4: Hook ridge strap and ratchet strap into eyebolts. Position ratchet under strap to prevent tarp wear.

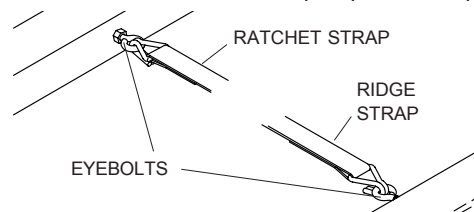

PREVENTS TARP WEAR

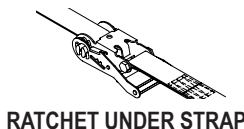

RATCHET UNDER STRAP

CAUSES TARP WEAR



RATCHET OVER STRAP

STEP 5: Thread strap through ratchet and tighten.

NOTE: Keep ridge straps tight for adequate tarp support. Check tension regularly.

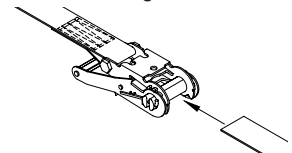

NOTE: See page 18 for U-clamp installation.

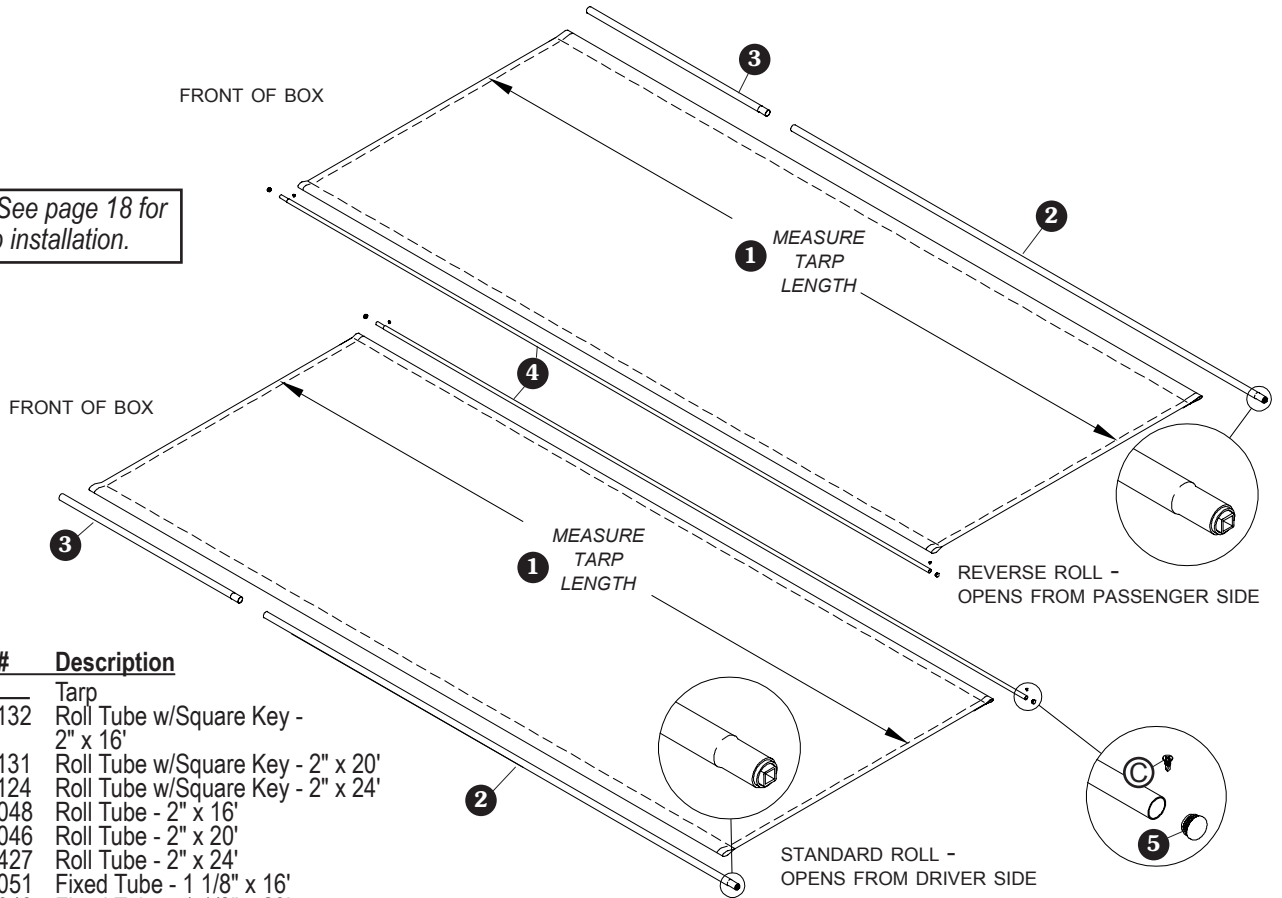

Item	Part #	Description
1.	*	Tarp
2.	1105132	Roll Tube w/Square Key - 2" x 16'
	1105131	Roll Tube w/Square Key - 2" x 20'
	1105124	Roll Tube w/Square Key - 2" x 24'
3.	1700048	Roll Tube - 2" x 16'
	1700046	Roll Tube - 2" x 20'
	1701427	Roll Tube - 2" x 24'
4.	1700051	Fixed Tube - 1 1/8" x 16'
	1700049	Fixed Tube - 1 1/8" x 20'
	1701428	Fixed Tube - 1 1/8" x 24'
5.	1700523	Plastic End Plug
C.	1704768	Self-Drilling Screw - 1/4" x 3/4"

*Specify box length and width

STEP 1: Open tarp and stretch tight. Measure tarp length and compare with tarp length specified on sheet attached to tarp. Do not proceed with installation if tarp length doesn't match length specified on sheet. Call Shur-Co® or your local dealer for alterations or a replacement tarp.

NOTE: Tarps cannot be returned at Shur-Co's expense beyond this point. Damaged tarps may be returned for repair or replacement at owner's expense.

FIXED TUBE

STEP 2: For boxes over 24', insert swaged end of fixed tube into full end of second tube section. Align tubes, weld and grind smooth.

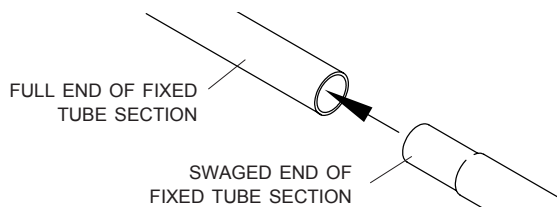

STEP 3: Cut fixed tube 2" longer than tarp, removing swaged end. Grind cut edge smooth.

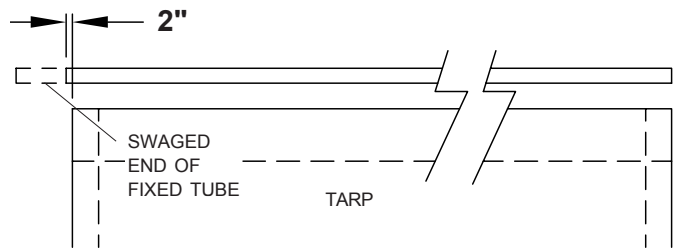

STEP 4: Install end plugs into ends of fixed tube.

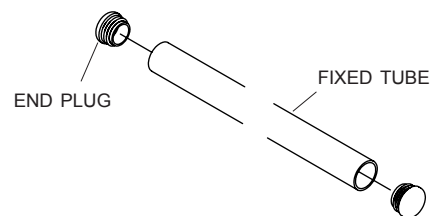

STEP 5: Insert fixed tube into 4" tarp pocket. Extend tube 1" past tarp edge and secure with screw .

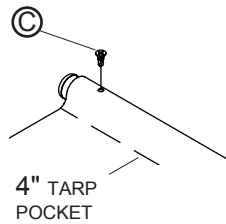

STEP 6: Stretch tarp along fixed tube and fasten second screw on other end of fixed tube.

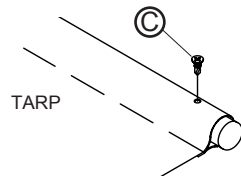

ROLL TUBE

STEP 1: For box lengths over 24', insert swaged end of roll tube section into full end of second tube section. Align tubes, weld and grind smooth.

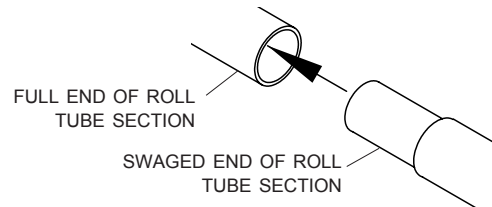

STEP 2: Insert roll tube into 5" tarp pocket with square key at rear of tarp.



TIP: Inflate 5" tarp pocket with air chuck while inserting roll tube.

STEP 3: Wind tarp completely around roll tube, then lift rolled-up tarp assembly onto fixed tube side of box.

STEP 4: Center tarp on box, overlapping end caps 6" to 9", with fixed tube hanging over edge of box. Square up tarp and fixed tube.

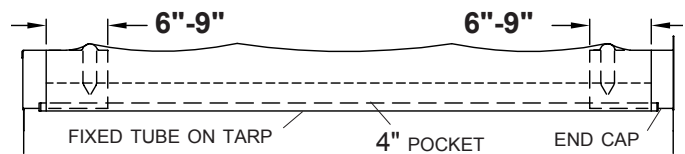

Item	Part #	Description
1.	1700729	Protective Cap
2.	1100049	Standard Tarp Stop
3.	1100392	Offset Tarp Stop
4.	1105163	Recessed Tarp Stop
G.	1700400	Self-Tapping Screw - 3/8" x 1"
S.	1700434	Lock Washer - 3/8"
N.	1700407	Hex Nut - 3/8"

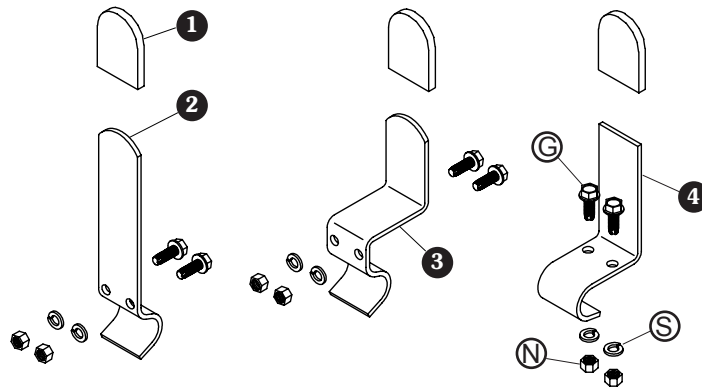

STEP 1: Locate first tarp stop 14" to 18" from rear edge of tarp. Mark and drill holes. Hook tarp stop over fixed tube and fasten to box with screws (G), lock washers (S) and nuts (N).

NOTE: See note under Hardware Identification on page 1 for drill size.

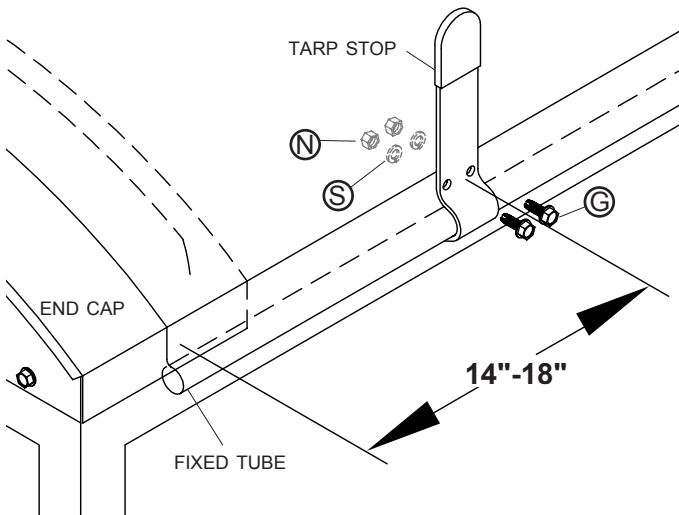

STEP 2: Square up tarp on box. Locate second tarp stop 14" to 18" from front edge of tarp. Mark and drill holes. Hook tarp stop over fixed tube. Fasten to box with screws (G), lock washers (S) and nuts (N).

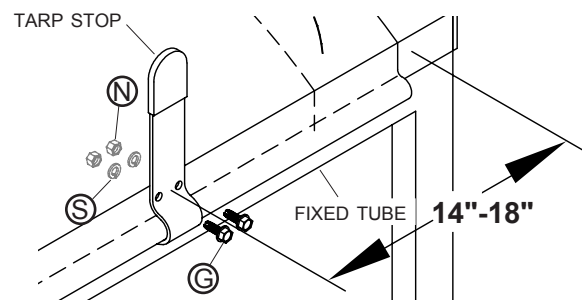

STEP 3: Equally space remaining tarp stops. Mark and drill holes and fasten to box with screws (G), lock washers (S) and nuts (N).

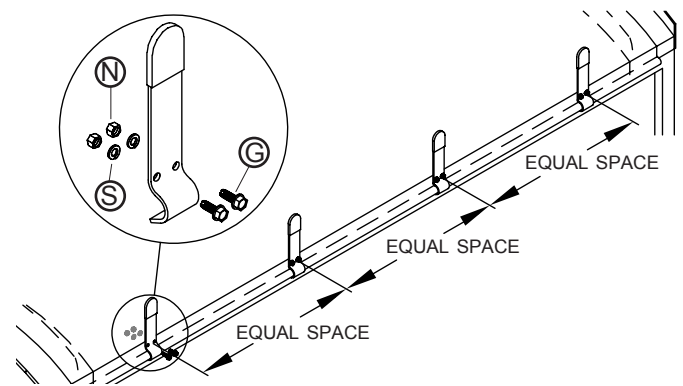

Item	Part #	Description
1.	1705775	Easy-Off Aluminum (Cast) Tarp Stop Upright
2.	1705454	Easy-Off Aluminum (Cast) 6" Offset Tarp Stop Upright
3.	1115216	Easy-Off Flexible Tarp Stop Upright w/Plate
4.	1115217	Easy-Off Flexible 6" Offset Tarp Stop Upright w/Plate
5.	1100833	Easy-Off Tarp Stop Body
6.	1704380	Bowtie Cotter Pin
7.	1703604	Clevis Pin - 5/16" x 2 7/8"
G.	1700400	Self-Tapping Screw - 3/8" x 1"
S.	1700434	Lock Washer - 3/8"
N.	1700407	Hex Nut - 3/8"

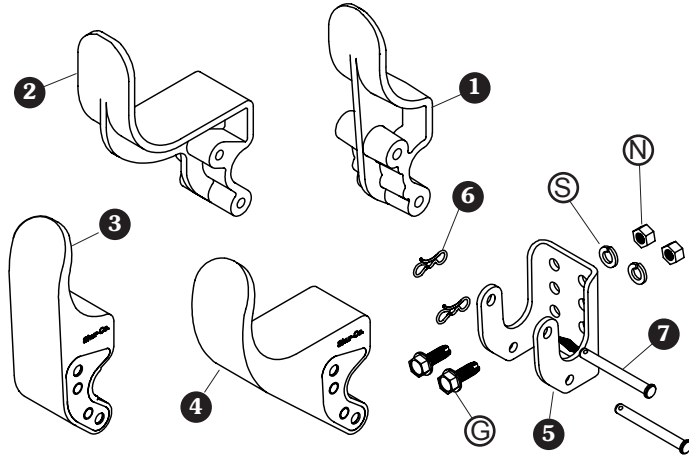

STEP 1: Locate first tarp stop body 14" to 18" from front edge of fixed tube and 1 1/4" below top of side rail. Mark and drill holes. Fasten to box with screws G, lock washers S and nuts N.

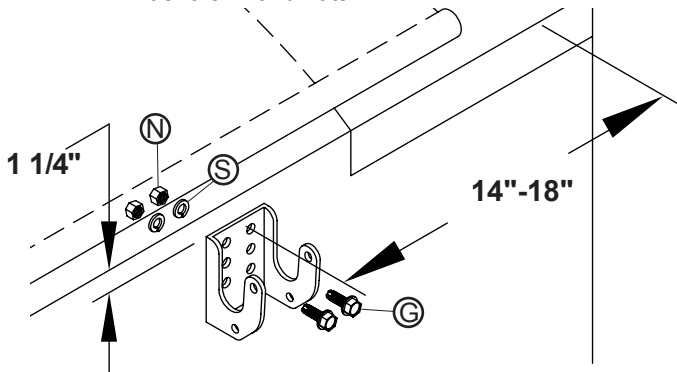

NOTE: See note under Hardware Identification on page 1 for drill size.

NOTE: Install tarp stop body on vertical surface. Fasten through pair of holes that best fit top rail configuration.

STEP 2: Square up tarp along length of box. Locate second tarp stop body 14" to 18" from rear edge of fixed tube and 1 1/4" below top of side rail. Mark and drill holes and fasten to box with screws G, lock washers S and nuts N.

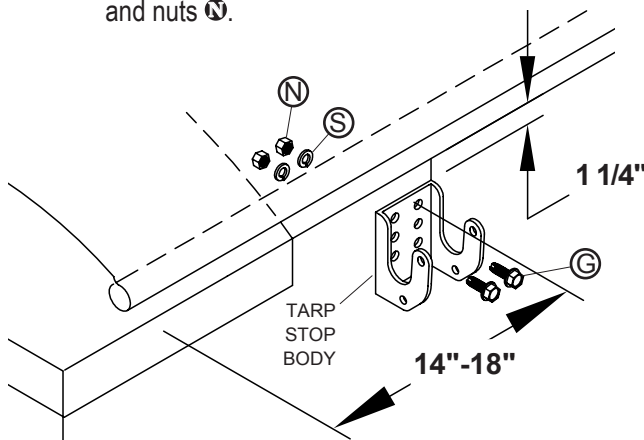

STEP 3: Equally space remaining tarp stop bodies. Mark and drill holes and fasten to box with screws G, lock washers S and nuts N.

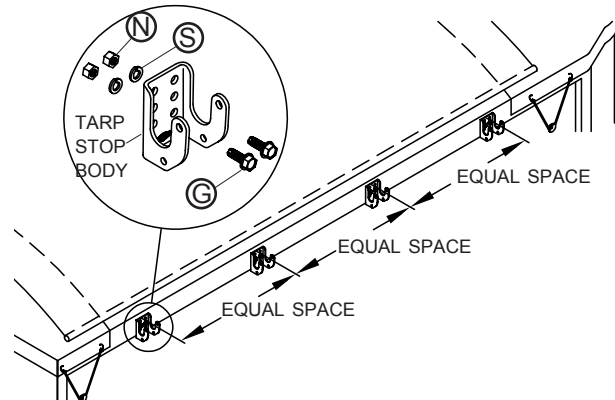

STEP 4: Adjust tarp so fixed tube rests squarely in tarp stop bodies.

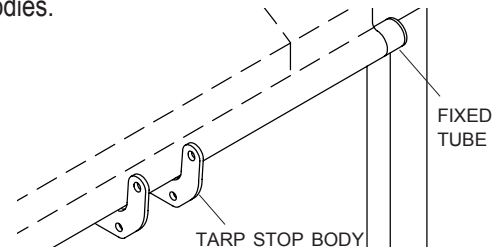

STEP 5: Fasten tarp stop uprights to tarp stop bodies with clevis pins. Secure with bowtie cotter pins.

NOTE: Align bowtie cotter pins toward rear of trailer as shown.

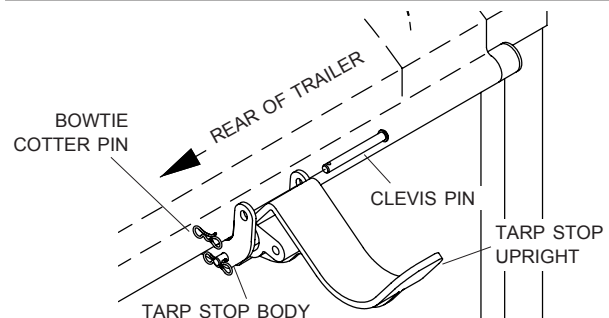

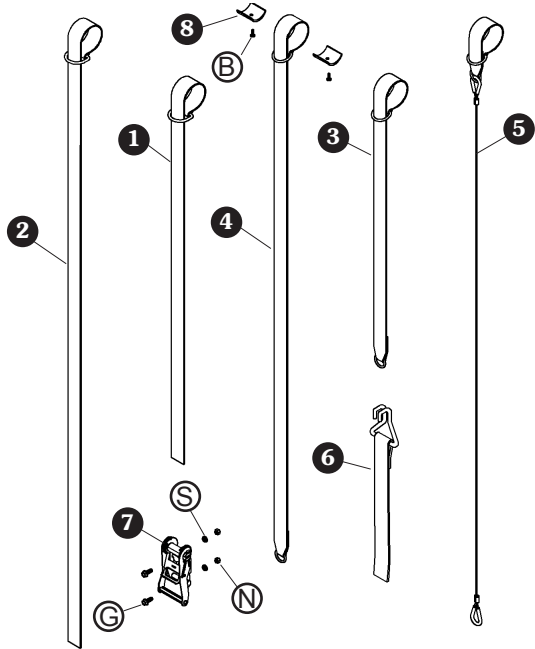

Item	Part #	Description
1.	1100470	Strap Assembly - 5'
2.	1106774	Strap Assembly - 9'
3.	1107222	Wire Hook Strap Assembly - 5'
4.	1107223	Wire Hook Strap Assembly - 7'
5.	1106763	Cable Assembly w/Hook - 7'
6.	1106754	Web Assembly w/Hook
7.	1100457	Ratchet - 2"
8.	1701354	Plastic U-Clamp
B.	1700398	Self-Drilling Screw - 1/4" x 3/4"
G.	1700400	Self-Tapping Screw - 3/8" x 1"
N.	1700407	Hex Nut - 3/8"
S.	1700434	Lock Washer - 3/8"

CAUTION
Close tarp and secure ratchets before driving vehicle to prevent tarp from blowing off.

STEP 1: Locate first ratchet 14" to 18" from rear edge of tarp at convenient operating height. Locate second ratchet 14" to 18" from front edge of tarp at same height. Equally space remaining ratchets.

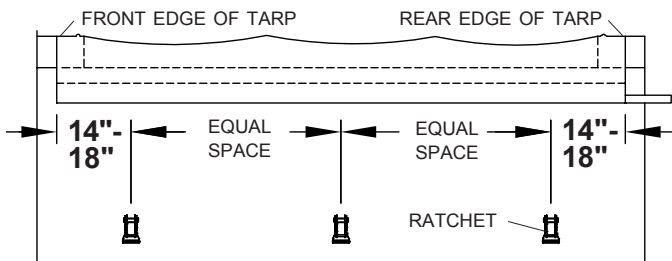

NOTE: Align ratchets with tarp stops on opposite side of box.

STEP 2: Mark and drill 5/16" holes and fasten with screws G, washers S and nuts N.

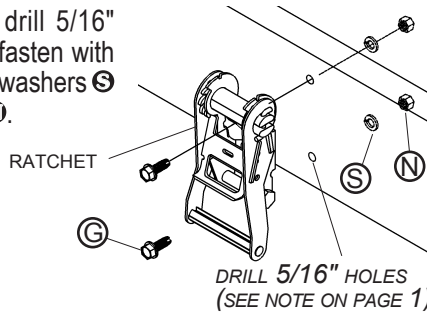

STEP 3: Cut 1" x 3" slots along bottom of 5" roll tube tarp pocket directly above ratchets. Round corners of slots with scissors.

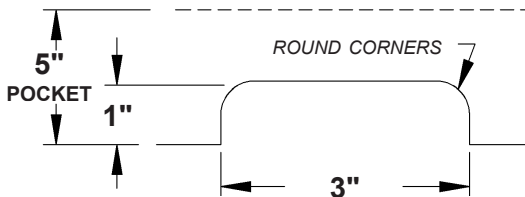

STEP 4: Extend roll tube 2" to 4" past farthest obstruction on rear of box. Cut front of roll tube to extend 1" past front of tarp. Grind cut edge smooth.

STEP 5: Thread straps or cables through slots, around roll tube and through D-ring.

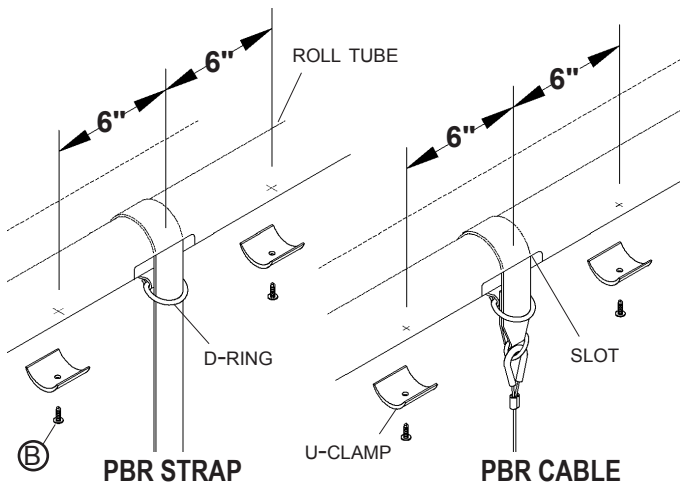

STEP 6: Mark U-clamp locations on both sides of cables or straps, 6" from center. Install U-clamps with self-drilling screws B.

STEP 7: Hook straps to ratchets as shown. Tighten straps securely before driving vehicle.

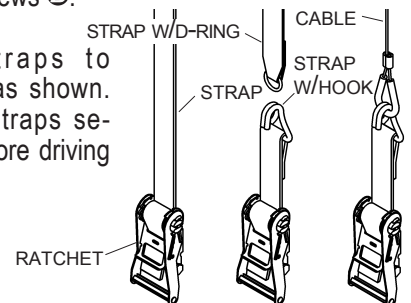

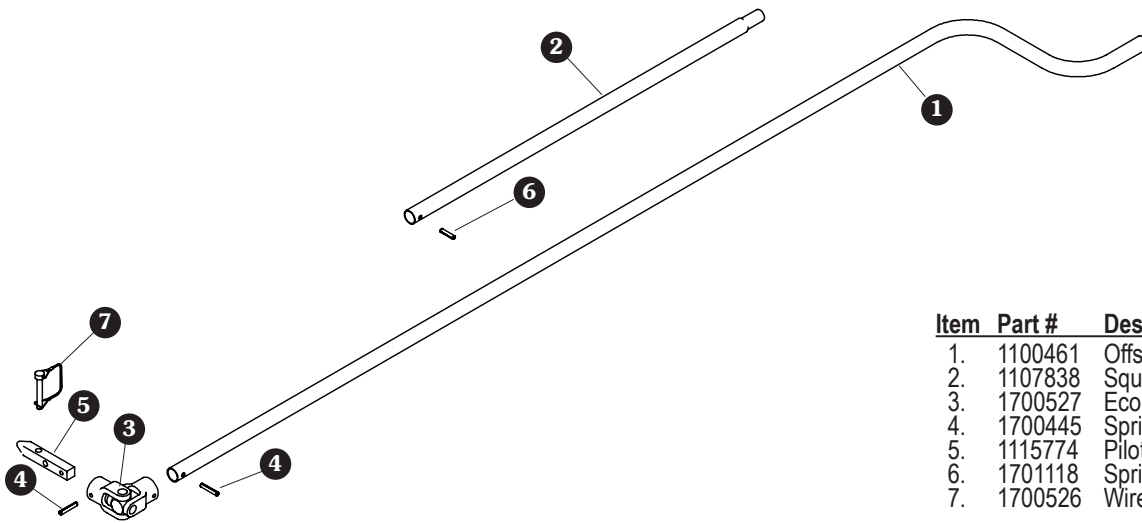

Item	Part #	Description
1.	1100461	Offset Crank Arm
2.	1107838	Square Crank Extension - 33"
3.	1700527	Econo U-Joint
4.	1700445	Spring Pin - 1/4" x 1 1/2"
5.	1115774	Pilot Crank Key
6.	1701118	Spring Pin - 1/4" x 1 3/16"
7.	1700526	Wire Lock Pin - 3/8" x 2 1/2"

STEP 1: (Optional) Insert crank extension into crank arm. Fasten with 1/4" x 1 3/16" spring pin.

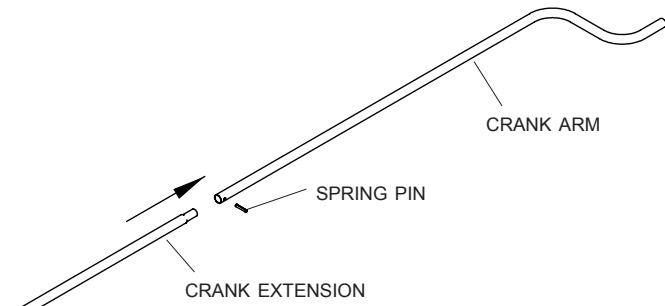

STEP 2: Insert crank arm/extension into U-joint. Secure with 1/4" x 1 1/2" spring pin.

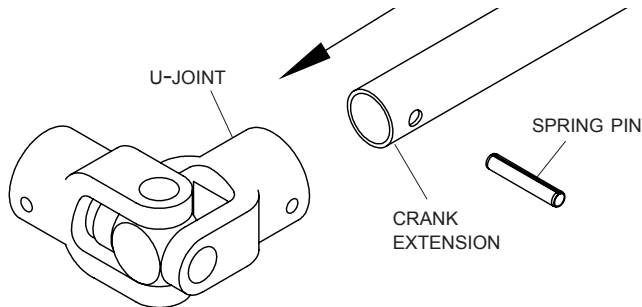

STEP 3: Insert crank key into U-joint. Secure with 1/4" x 1 1/2" spring pin.

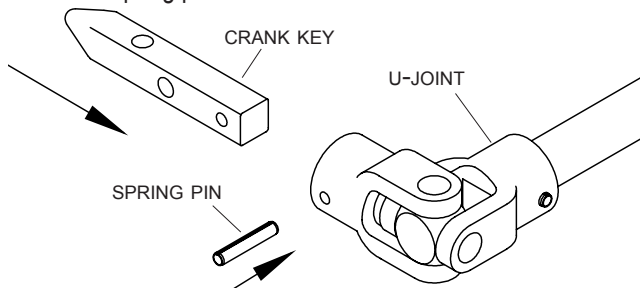

CRANK OPERATION OPTIONS:

Removable crank operation: Open tarp with removable crank arm, remove crank arm and close tarp with rope. Store crank arm on box.

Fixed crank operation: Open and close tarp with fixed crank arm. Hook crank arm into crank retainer on rear of box.

REMOVABLE CRANK OPERATION

STEP 4A: To roll tarp open, insert crank key into square key on roll tube at rear of box. Remove crank arm after opening tarp.

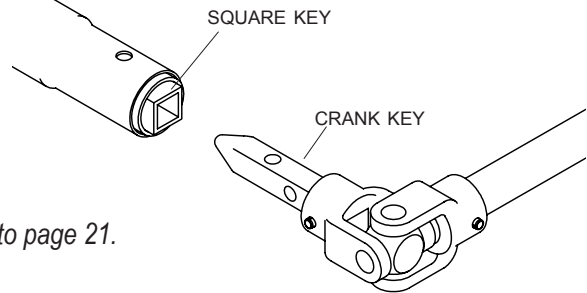

Go to page 21.

FIXED CRANK OPERATION

STEP 4B: Insert crank key into square key on roll tube at rear of box. Align holes and fasten with wire lock pin.

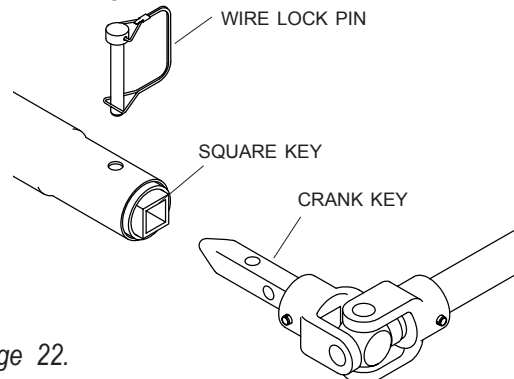

Go to page 22.

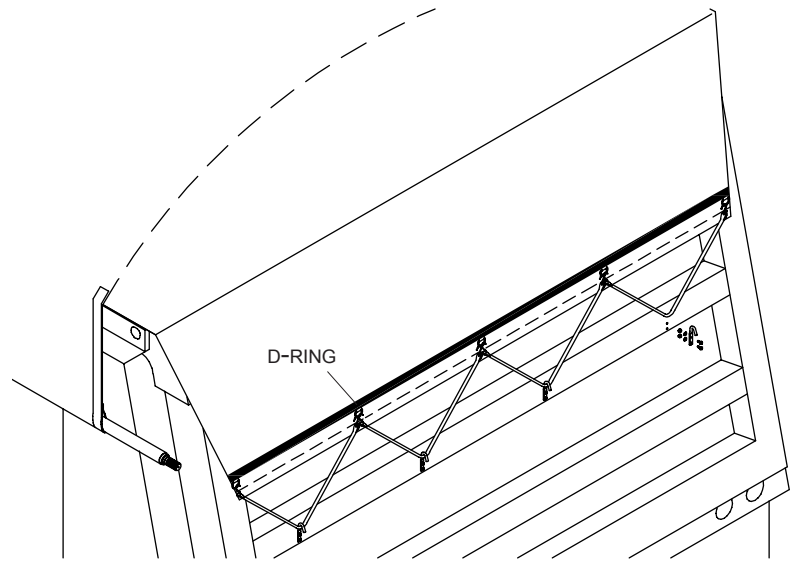
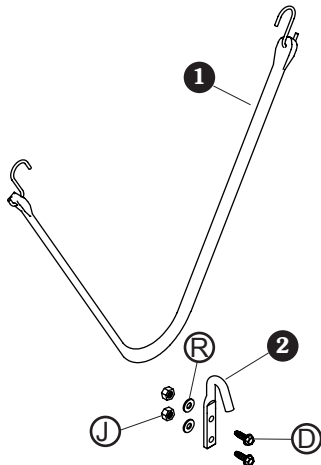

Item	Part #	Description
1.	1700650	Rubber Tarp Strap
2.	1700682	Box Hook - 5/16" Holes
D.	1700403	Self-Tapping Screw - 1/4" x 3/4"
R.	1700427	Flat Washer - 1/4"
J.	1701543	Nylon Lock Nut - 1/4"

STEP 1: Install rear bow and bow brackets per bow instructions, locating bow as close to tailgate as possible without interfering with tailgate operation. Align bow height with height of previously installed bows.

STEP 2: Roll tarp closed over bows. Pull poorboy tail flap squarely over rear of box.

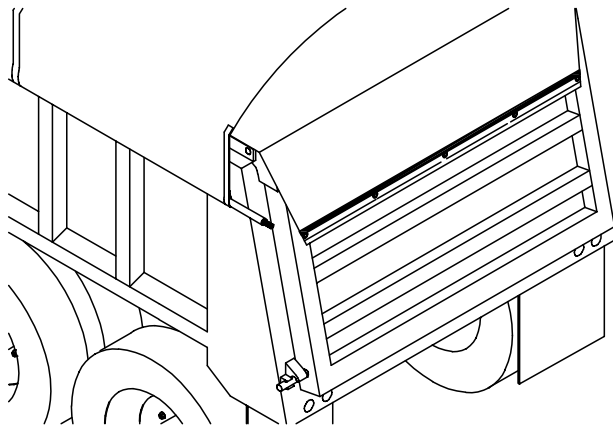

STEP 3: Hook rubber straps into D-rings on poorboy tail.

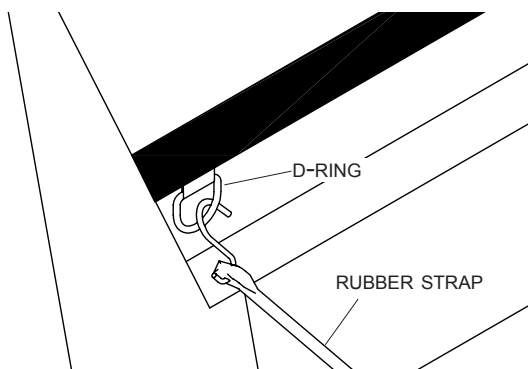

STEP 4: Locate and install box hooks so rubber straps will have at least 10 pounds of force pulling on them. Drill 13/64" holes and fasten box hooks with 1/4" screws, washers and nuts.

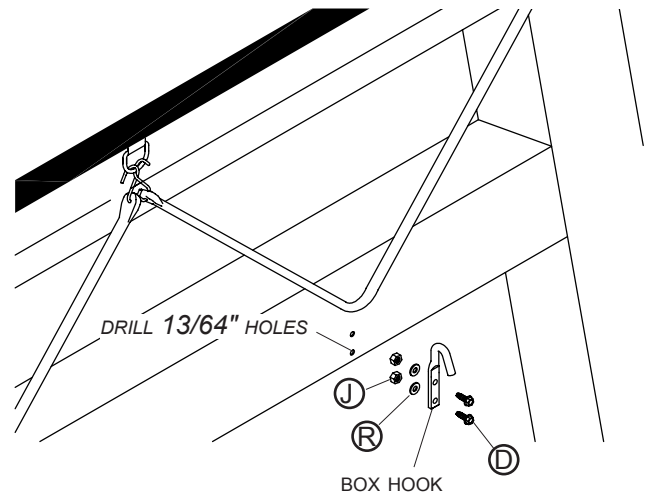

STEP 5: Release rubber straps from box hooks and fold flap over tarp before rolling tarp open. Close tarp and secure rubber straps to box hooks before traveling.

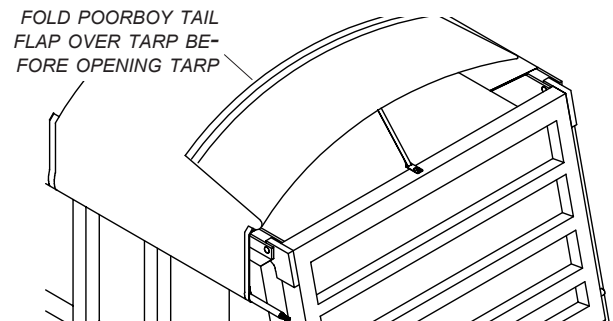

Item	Part #	Description
1.	1101930	Offset J-Hook Crank Retainer
2.	1700526	Wire Lock Pin - 3/8" x 2 1/2"
3.	1100574	Cable w/#5 Interlock Snap
4.	1700682	Box Hook - 5/16" Holes
5.	1100469	Rope - 32'
E.	1700381	Cap Screw - 1/4" x 1"
G.	1700400	Self-Tapping Screw - 3/8" x 1"
H.	1700408	Hex Nut - 1/4"
N.	1700407	Hex Nut - 3/8"
Q.	1700436	Lock Washer - 1/4"
S.	1700434	Lock Washer - 3/8"

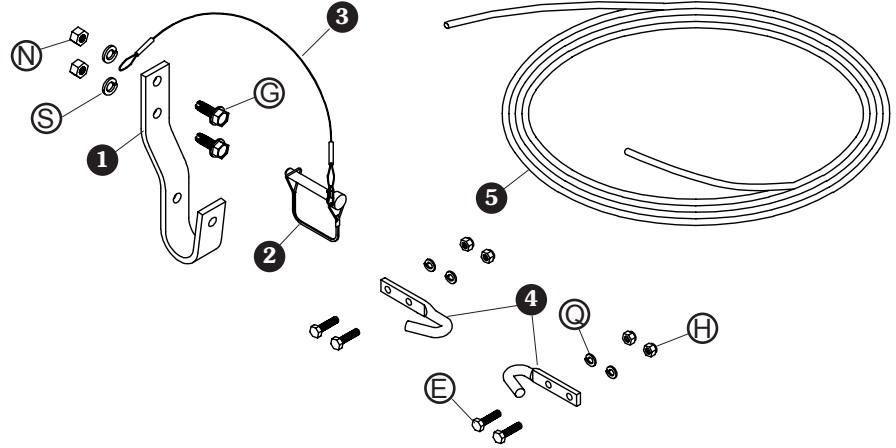

STEP 1: Locate and align crank retainers in convenient location to store crank arm.

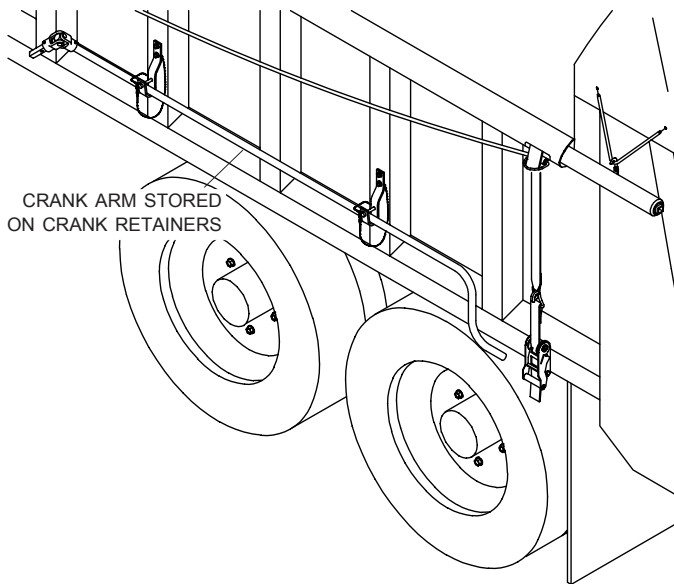

STEP 2: Mark and drill holes and fasten crank retainers to side of box with screws **G**, lock washers **S** and nuts **N**. Fasten cable between crank retainer and box.

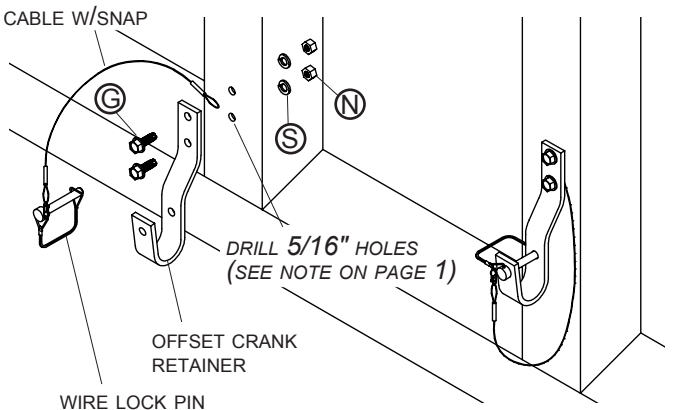

STEP 3: Melt hole in tarp at center of box. Tie loop in end of rope return. Thread loop through hole and pull loose end of rope through loop.

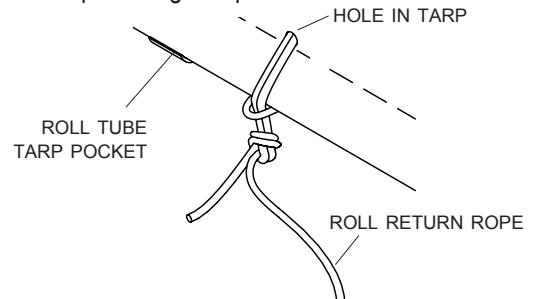

STEP 4: Locate box hooks to prevent interference with ratchet operation. Mark and drill 3/16" holes and fasten with screws **E**, washers **Q** and nuts **H**.

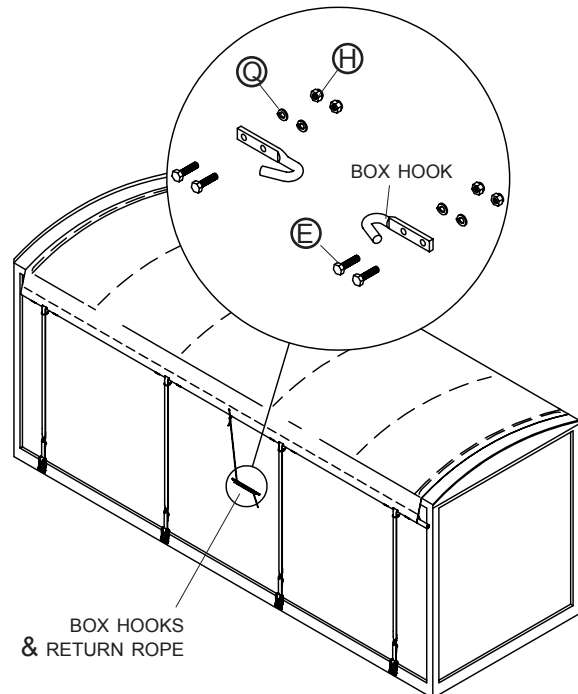

STEP 5: Wrap return rope around box hooks for storage while tarp is closed.

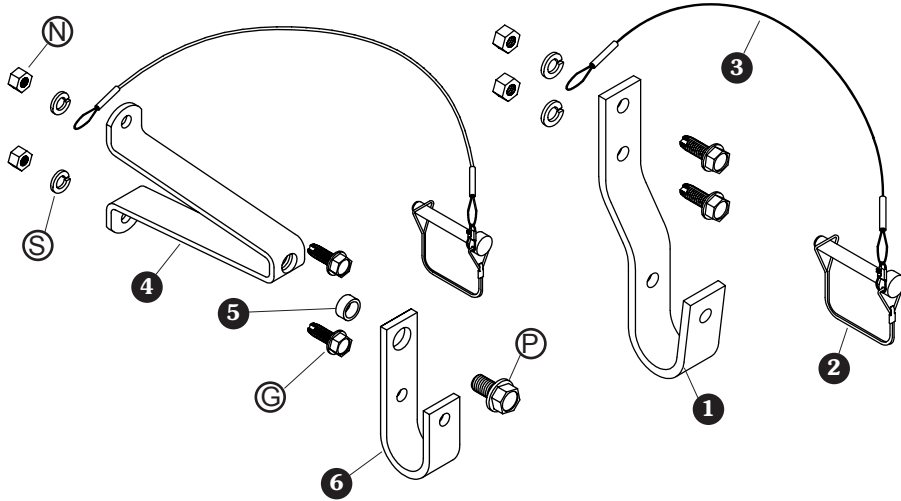

Item	Part #	Description
1.	1101930	Offset J-Hook Crank Retainer
2.	1700526	Wire Lock Pin - 3/8" x 2 1/2"
3.	1100574	Cable w/#5 Interlock Snap
4.	1109478	Crank Retainer Standoff - 11"
	1100033	Crank Retainer Standoff - 7"
	1107080	Crank Retainer Standoff - 3"
	1100137	Crank Retainer Standoff - 2"
5.	1100306	Retainer Bushing - 11/16"
6.	1100040	J-Hook Crank Retainer
G.	1700400	Self-Tapping Screw - 3/8" x 1"
N.	1700407	Hex Nut - 3/8"
P.	1702996	Cap Screw - 1/2" x 1 1/4"
S.	1700434	Lock Washer - 3/8"

STEP 1: If using J-hook crank retainer, assemble as shown.

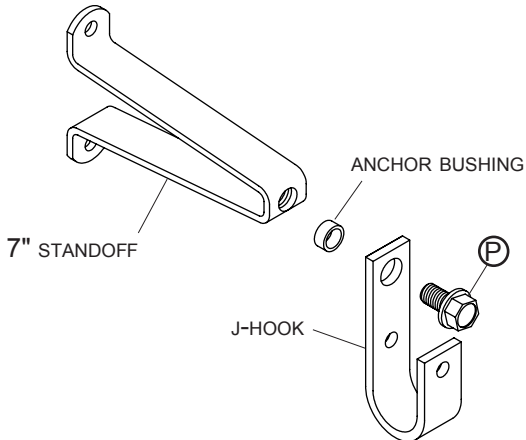

STEP 2: With tarp closed, rotate crank arm across rear of box to determine crank retainer position. Position crank retainer to hold crank arm securely in place.

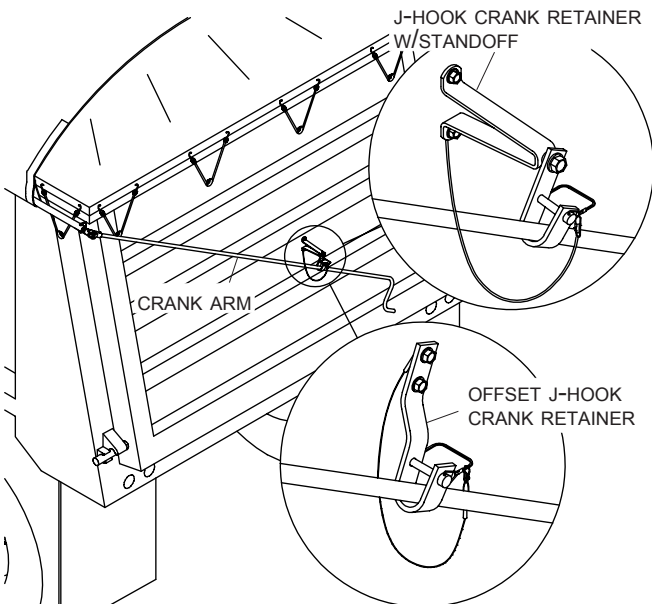

STEP 3: Mark and drill 5/16" holes and fasten crank retainer to box with screws G, lock washers S and nuts N. Fasten cable with snap and wire lock pin between standoff and box.

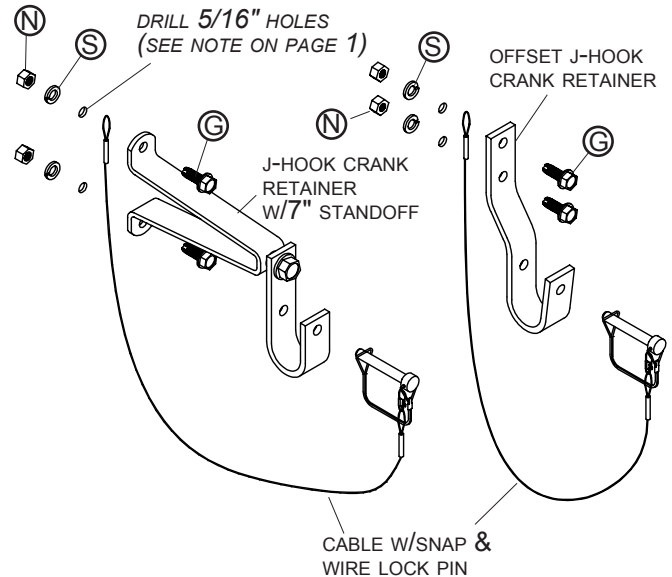

STEP 4: Hold crank firmly with both hands and roll tarp closed.

NOTE: Stretch cord return and gravity will force roll tube and crank arm downward when opening and closing tarp. Hold crank firmly with both hands while opening and closing tarp to prevent crank arm from spinning.

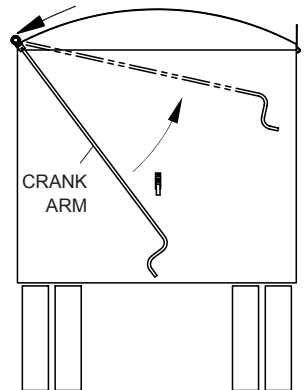

Item Part # Description

- 1. 1111067 Roll Return Tube Set - 2 Pc.
- 2. 1114360 Roll Return Stretch Cord - 11 1/2'
- 3. 1100138 Nylon End Plug
- 4. 1107680 Protective Stretch Cord Cover
- A. 1704743 Self-Drilling Screw - #10 x 1/2"
- K. 1700411 Hex Nut - 5/16"
- L. 1700419 Nylon Lock Nut - 5/16"
- U. 1703373 Flat Washer - 1/2"
- V. 1700717 Eyebolt Anchor - 5/16"

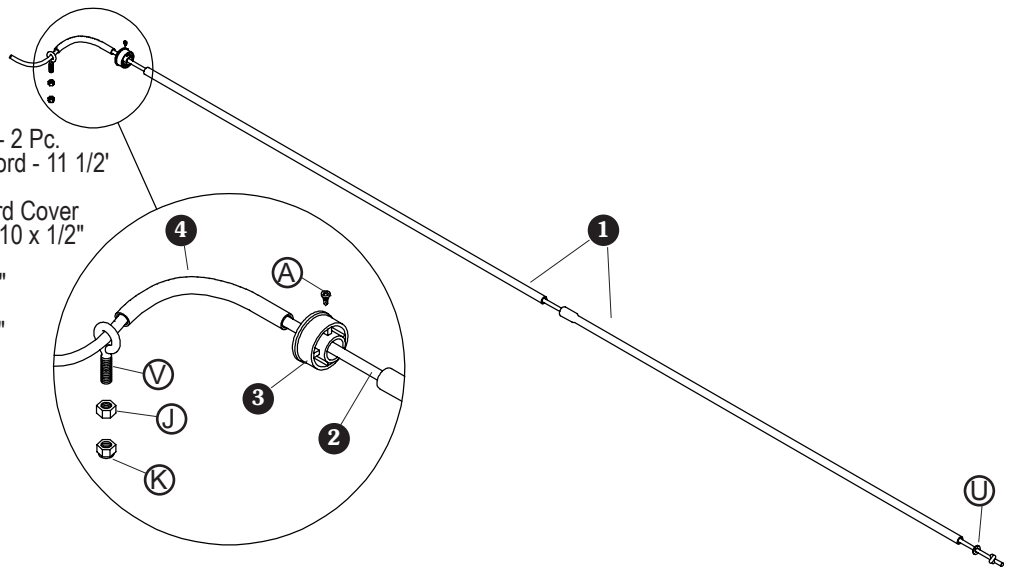

STEP 1: Insert straight pipe into belled pipe. Insert end plug into straight pipe.

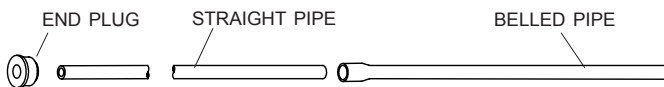

STEP 2: Insert stretch cord through end plug and pipes. Slide flat washer over stretch cord and tie knot in cord.

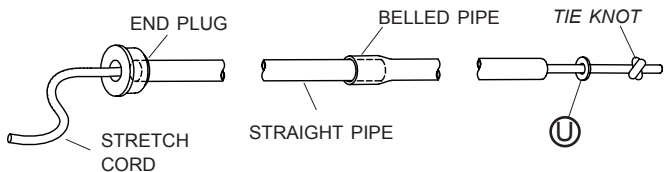

STEP 3: Insert stretch cord return into roll tube. Lightly tap end plug into roll tube.

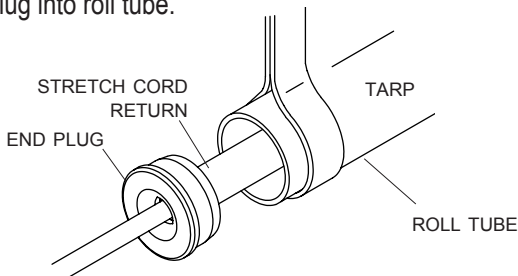

STEP 4: Mark location about 7/16" from edge of end plug. Secure end plug to roll tube with self-drilling screw.

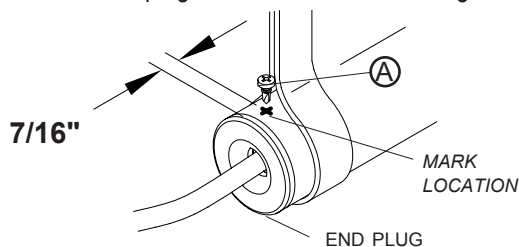

STEP 5: Drill 13/32" hole through box, 1 1/2" from edge of tarp and 2 1/2" to 5 1/2" down from top edge of top rail. Insert eyebolt through hole and secure with nut and lock nut.

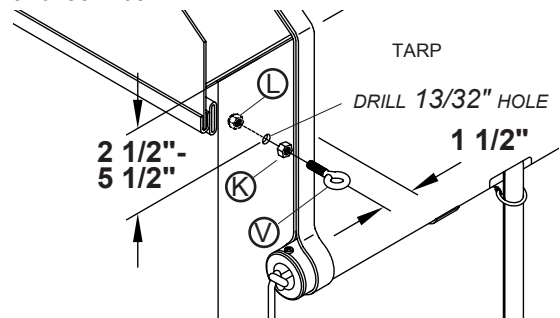

STEP 6: With tarp hanging over edge of box, pull stretch cord to remove all slack in stretch cord return. Tie knot. Slide protective cover over stretch cord.

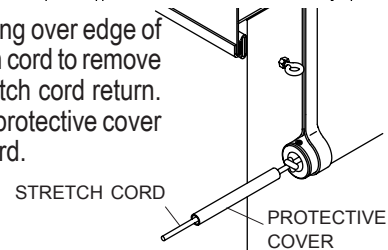

STEP 7: Thread stretch cord through eyebolt. Pull cord to create enough tension to almost lift roll return. Tie knot.

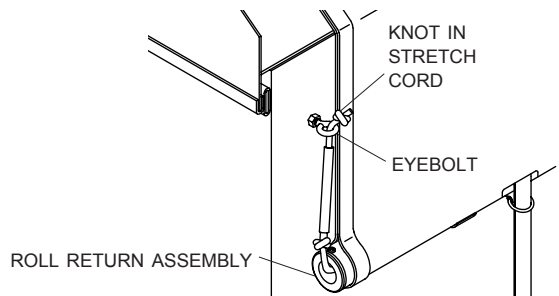

STEP 8: Cut off excess stretch cord. Melt end to prevent fraying.

The Premium Belt & Ratchet system is designed to provide years of reliable service. Follow installation instructions, maintenance schedule and operating instructions provided to receive years of service from your PBR system. Incorrect operation or lack of maintenance can severely impair operation of the system and cause premature tarp and cable wear.

Maintenance Schedule

Perform the following procedures every 2 to 4 weeks:

1. Inspect tarp - repair any tears, cuts or worn areas.
2. Inspect hardware - securely tighten any loose fasteners.

Operating Instructions - Manual Crank

To uncover load:

1. Release all hold-down straps from ratchets.
2. Unwrap rope return from storage hooks.
3. Remove crank from crank retainers and insert square key into square end of roll tube.
4. Turn crank clockwise (counter-clockwise for reverse roll) until tarp has rolled up against tarp stops.
5. Detach crank from roll tube and place crank back into crank retainers.

To cover load:

1. Pull rope return to roll tarp closed.
2. Store rope return by wrapping rope around storage hooks.
3. Connect hold-down straps to ratchets and ratchet straps down until tarp is correctly tensioned.

Operating Instructions - Fixed Crank

To uncover load:

1. Release all hold-down straps from ratchets.
2. Release crank from crank retainer.
3. Turn crank clockwise (counter-clockwise for reverse roll) until tarp has rolled up against tarp stops.
4. Place crank back into crank retainer.

To cover load:

1. Release crank from crank retainer.
2. Turn crank counter-clockwise (clockwise for reverse roll) until tarp is hanging over edge of trailer, completely unrolled.
3. Place crank back into crank retainer.
4. Connect hold-down straps to ratchets and ratchet straps down until tarp is correctly tensioned

Close cover at all times except when loading or unloading to extend the life of your PBR system.

Open cover while unloading box. Unloading box with cover closed will create a vacuum which could damage your system.

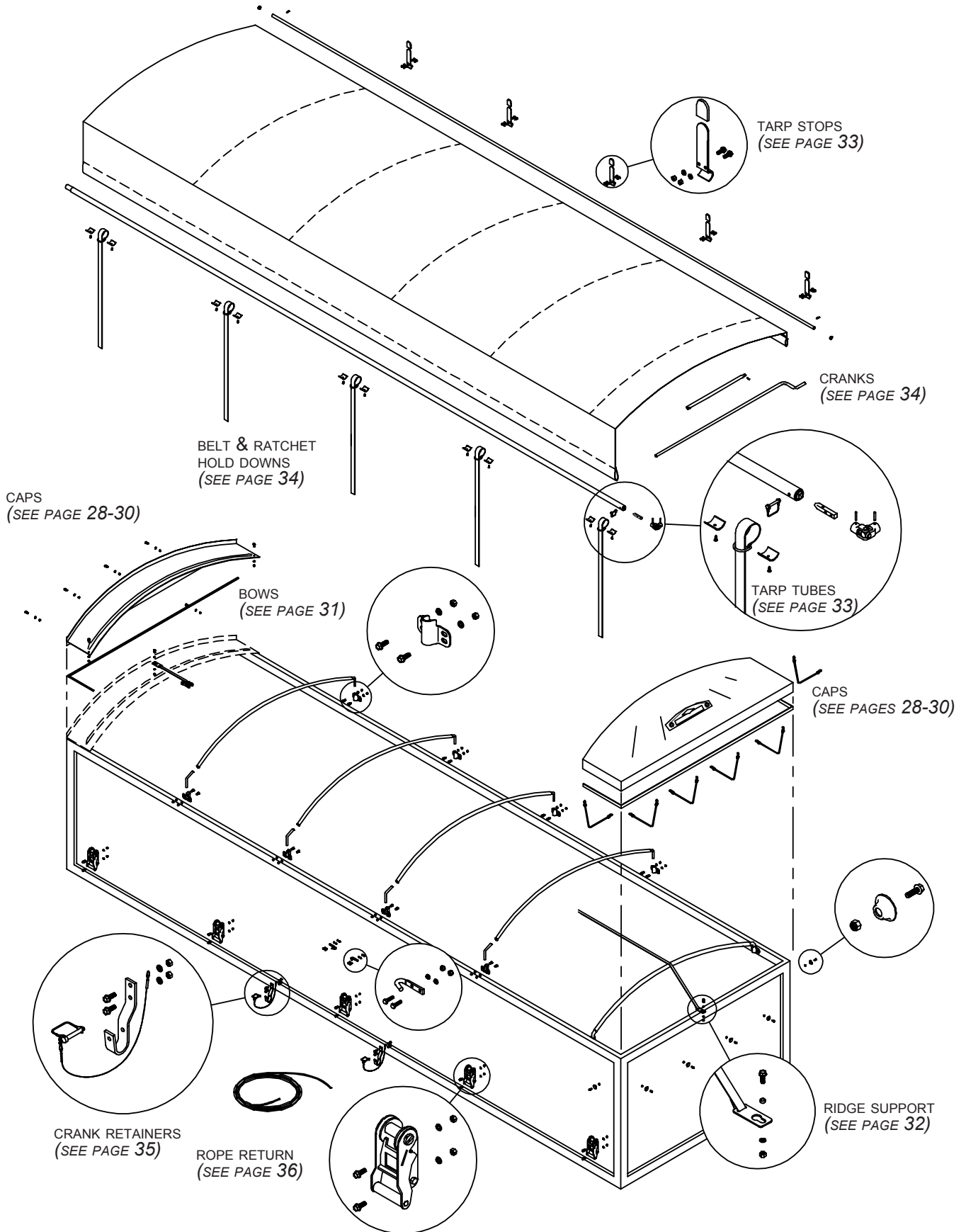

END CAPS - FABRIC BACK

Item	Part #	Description
	1100640	Single Back Low-Rise Standard Fabric Cap Hdw.
	1113359	Single Back Low-Rise Standard Fabric Cap Hardware - Single Bow Bracket
	1100639	Single Back High-Rise Standard Fabric Cap Hdw.
	1113360	Single Back High-Rise Standard Fabric Cap Hardware - Single Bow Bracket
	1102903	Single Back Low-Rise Heavy-Duty Fabric Cap/Flap Hdw.
	1102829	Single Back High-Rise Heavy-Duty Fabric Cap/Flap Hdw.
1.	1100760	Standard Low-Rise Bow - 93" to 102"
	1100762	Standard High-Rise Bow - 96" to 102"
2.	1120836	Single Bow Bracket
3.	1700400	Self-Tapping Screw - 3/8" x 1"
4.	1700407	Hex Nut - 3/8"
5.	1700434	Lock Washer - 3/8"
6.	1100695	Standard Low-Rise Bow Shank
	1106925	Standard High-Rise Bow Shank
7.	1106612	Heavy-Duty Low-Rise Bow
	1101927	Heavy-Duty High-Rise Bow
8.	1104123	Heavy-Duty Bow Pin
9.	1104706	Heavy-Duty Bow Shank
10.	1106614	Heavy-Duty Bow Bracket
11.	1701098	Lynch Pin - 5/16" x 1 3/4"
12.	1700990	Shock Cord - 18"
13.	1701355	Rope Anchor
14.	1701059	Self-Tapping Screw - 5/16" x 1"
15.	1700419	Nylon Lock Nut - 5/16"
16.	1700581	Aluminum Flat Bar - 103"
17.	*	Fabric Insert Only
	*	Square Back - 96"
	*	Square Back - 102"
	*	Fabric Flap Insert Only
18.	*	Dump Flap - 96"
	*	Dump Flap - 102"

* Specify size

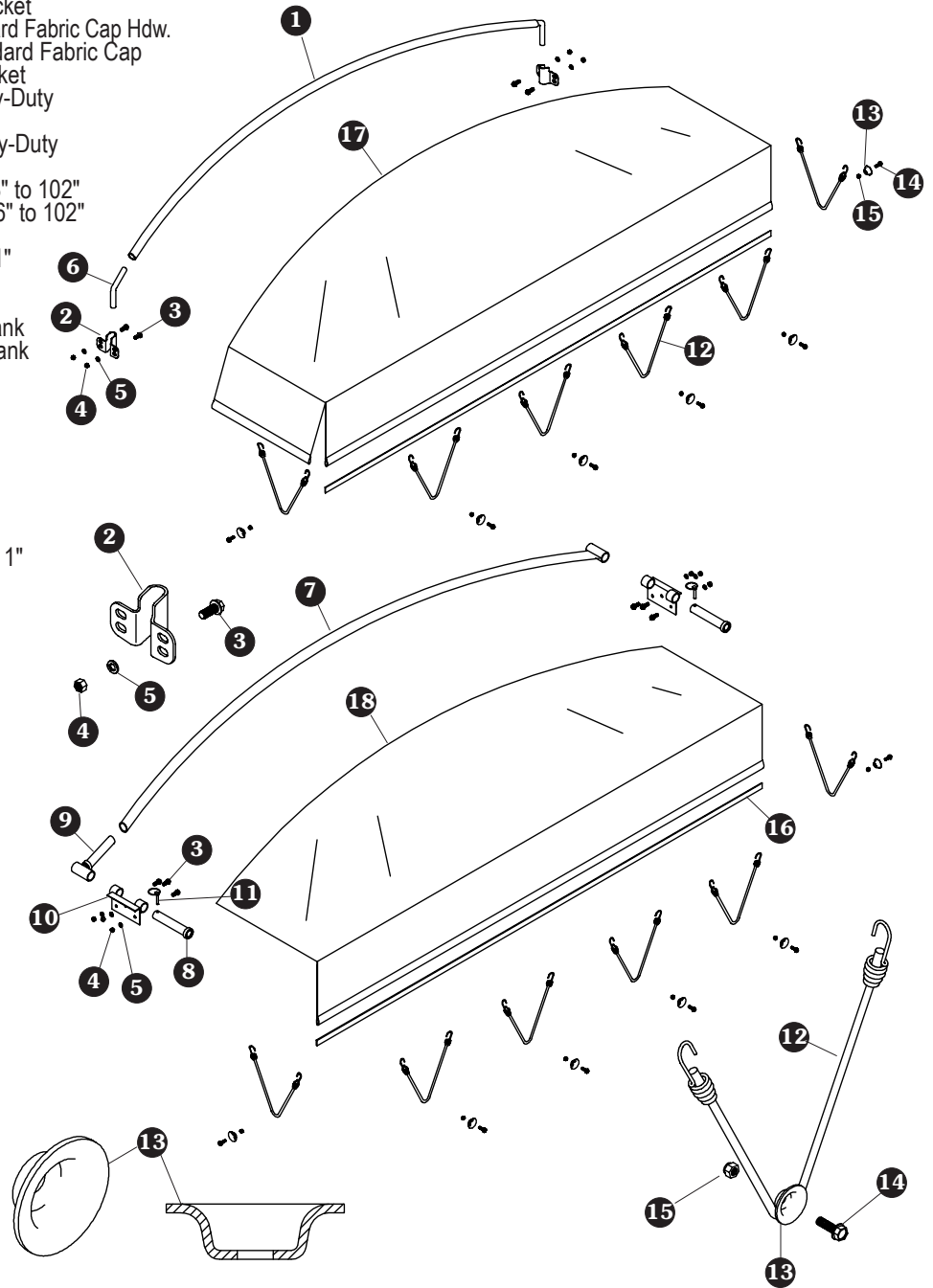

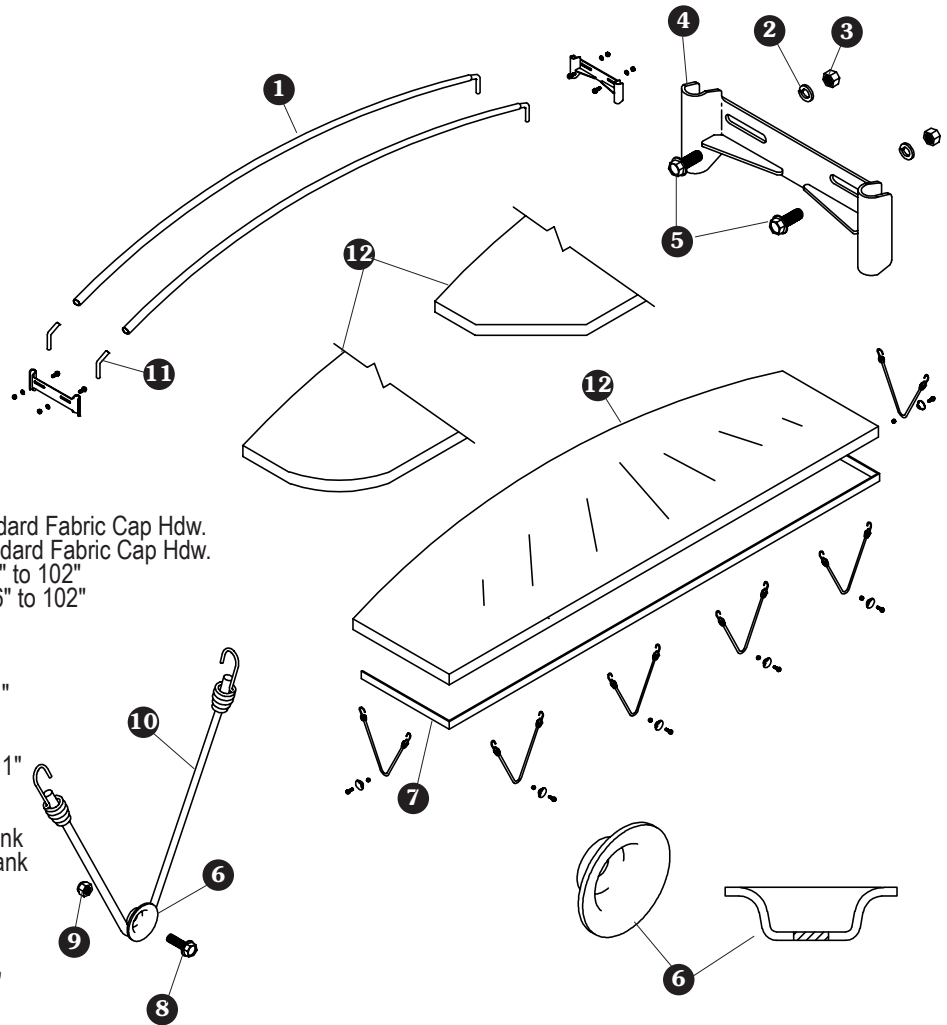

END CAPS - FABRIC FRONT

Item	Part #	Description
	1100642	Double Front Low-Rise Standard Fabric Cap Hdw.
	1100641	Double Front High-Rise Standard Fabric Cap Hdw.
1.	1100760	Standard Low-Rise Bow - 93" to 102"
	1100762	Standard High-Rise Bow - 96" to 102"
2.	1700434	Lock Washer - 3/8"
3.	1700407	Hex Nut - 3/8"
4.	1108211	Double Bow Bracket
5.	1700400	Self-Tapping Screw - 3/8" x 1"
6.	1701355	Rope Anchor
7.	1700581	Aluminum Flat Bar - 103"
8.	1701059	Self-Tapping Screw - 5/16" x 1"
9.	1700419	Nylon Lock Nut - 5/16"
10.	1700990	Shock Cord - 18"
11.	1100695	Standard Low-Rise Bow Shank
	1106925	Standard High-Rise Bow Shank
12.		Fabric Insert Only
	*	Square Front - 96"
	*	Square Front - 102"
	*	Radius/Diagonal Front - 96"
	*	Radius/Diagonal Front - 102"

* Specify size

END CAPS - ALUMINUM EASY-OFF

Item	Part #	Description
	1101934	Easy-Off Cap Mounting Hardware w/Rubber Seal
1.	1701115	Rubber Seal (per foot)
2.	1701113	Over-Center Clamp/Safety Clip
3.	1701218	D-Ring - 1 1/2"
4.	1701114	D-Ring Plate
5.	1701059	Self-Tapping Screw - 5/16" x 1"
6.	1700419	Nylon Lock Nut - 5/16"
7.	1100497	Belt'n Ratchet Decal
		Easy-Off Front Cap
8.	1107534	Easy-Off Front Low Rise - 94 1/2" to 96"
	1107540	Easy-Off Front High Rise - 94 1/2" to 96"
	1107537	Easy-Off Front Low Rise - 100" to 102"
	1107543	Easy-Off Front High Rise - 100" to 102"
		Easy-Off Back Cap
9.	1107554	Easy-Off Back Low Rise - 94 1/2" to 96"
	1107560	Easy-Off Back High Rise - 94 1/2" to 96"
	1107557	Easy-Off Back Low Rise - 100" to 102"
	1107563	Easy-Off Back High Rise - 100" to 102"

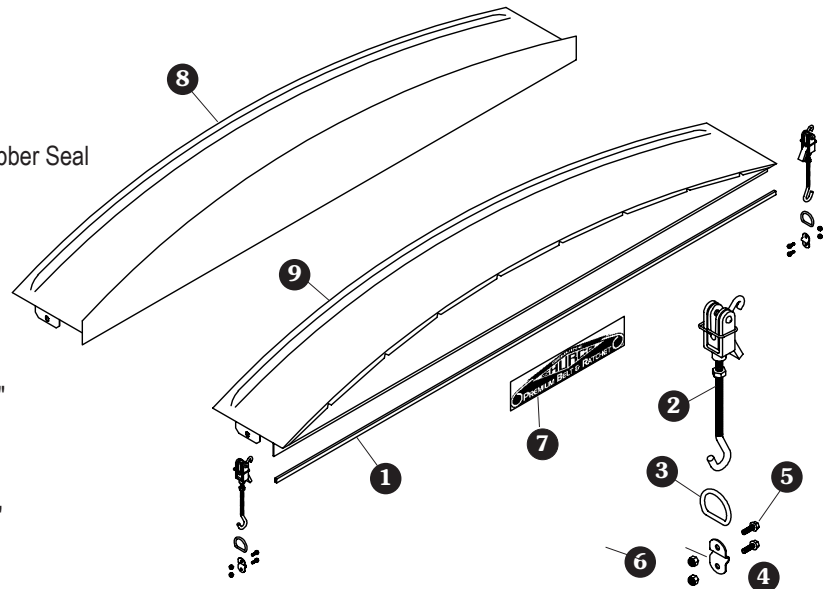

END CAPS - ALUMINUM

Item Part # Description

- 1107785 Alum. Cap Mounting Hardware w/Trim Seal - 110"
- 1107786 Alum. Cap Mounting Hardware w/Trim Seal - 132"
- 1107787 Metal Cap Mounting Hardware - Bolt Kit
- 1. 1100165 Trim Seal - 110"
- 1100357 Trim Seal - 132"
- 1700152 Trim Seal (per foot)
- 2. 1700400 Self-Tapping Screw - 3/8" x 1"
- 3. 1700434 Lock Washer - 3/8"
- 4. 1700407 Hex Nut - 3/8"
- 5. 1100497 Belt' n Ratchet Decal
- 6. 1701238 Rubber Windshield (per foot)

Aluminum Front Caps

- 7. 1107396 Square Corner Front Cap - 94" - Low Rise
- 1107395 Square Corner Front Cap - 95" - Low Rise
- 1107406 Square Corner Front Cap - 96" - Low Rise
- 1107480 Square Corner Front Cap - 102" - High Rise
- 1107493 Square Corner Front Cap - 96" - High Rise
- 1107514 Square Corner Front Cap - 102" - High Rise
- 8. * Radius/Diag. Front - Up to 96" - Low or High Rise
- * Radius/Diag. Front - 97" to 102" - Low or High Rise
- 9. * Universal Front - 96" - Flat, Low or High Rise
- * Universal Front - 102" - Flat, Low or High Rise
- 10. 1107422 Square Corner Front Cap - 96" - Flat
- 1107510 Square Corner Front Cap - 102" - Flat

Aluminum Back Caps

- 11. 1107417 Back Cap - 94" - Low Rise
- 1107420 Back Cap - 95" - Low Rise
- 1107426 Back Cap - 96" - Low Rise
- 1107483 Back Cap - 102" - Low Rise
- 1107501 Back Cap - 96" - High Rise
- 1107517 Back Cap - 102" - High Rise
- 1107421 Back Cap - 96" - Flat
- 1107512 Back Cap - 102" - Flat

* Specify size

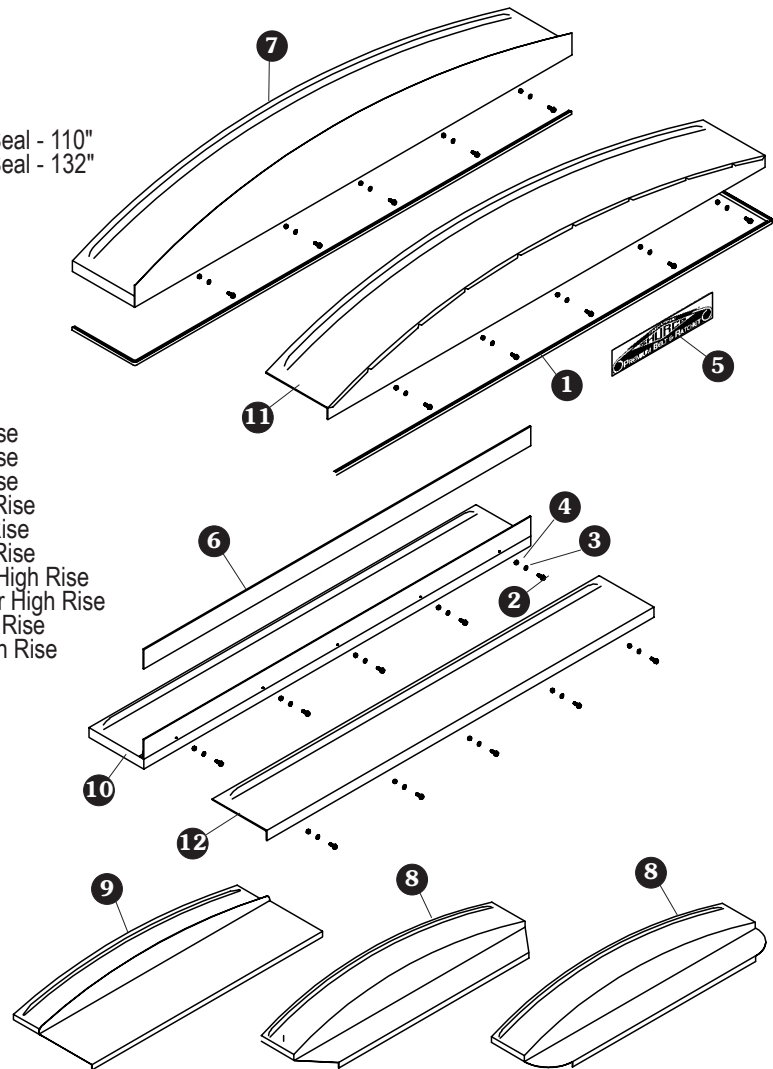

END CAPS - GALVANIZED STEEL

Item Part # Description

- 1107787 Metal Cap Mounting Hardware - Bolt Kit
- 1. 1108977 Galvanized Low Rise - 94" to 95" Box
- 1108980 Galvanized Low Rise - 96" to 97" Box
- 1108983 Galvanized Low Rise - 101" to 102" Box
- 2. 1108986 Galvanized High Rise - 94" to 95" Box
- 1108989 Galvanized High Rise - 96" to 97" Box
- 1108992 Galvanized High Rise - 101" to 102" Box
- 3. 1700400 Self-Tapping Screw - 3/8" x 1"
- 4. 1700434 Lock Washer - 3/8"
- 5. 1700407 Hex Nut - 3/8"
- 6. 1100497 Belt' n Ratchet Decal

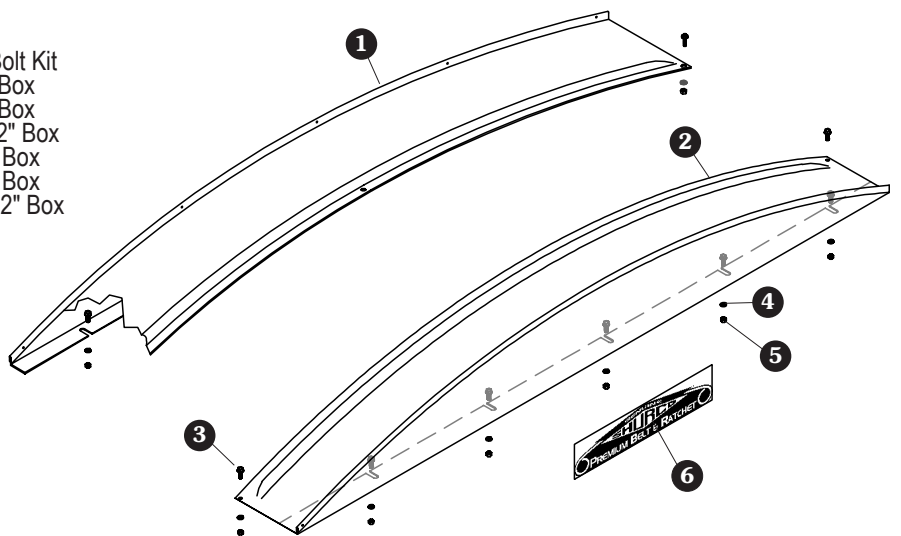

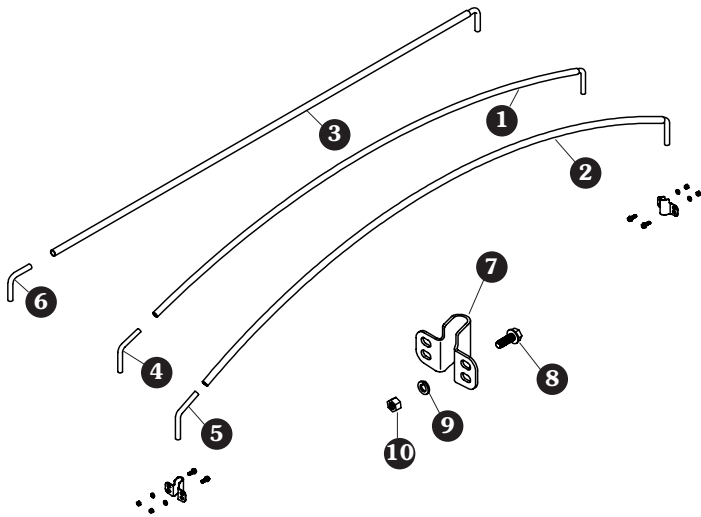

BOWS - STANDARD STEEL

Item	Part #	Description
	1111781	Standard Flat Bow Kit - 96" to 102"
	1100766	Standard Low-Rise Bow Kit - 93" to 102"
	1100768	Standard High-Rise Bow Kit - 96" to 102"
	1109139	Standard Low-Rise Bow Kit - Universal
	1109091	Standard High-Rise Bow Kit - Universal
1.	1100760	Standard Low-Rise Bow - 93" to 102"
2.	1100762	Standard High-Rise Bow - 96" to 102"
3.	1109149	Standard Flat Bow - 89" to 95"
4.	1100695	Standard Low-Rise Bow Shank
5.	1106925	Standard High-Rise Bow Shank
6.	1109150	Standard Flat Bow Shank
7.	1120836	Single Bow Bracket
8.	1700400	Self-Tapping Screw - 3/8" x 1"
9.	1700434	Lock Washer - 3/8"
10.	1700407	Hex Nut - 3/8"

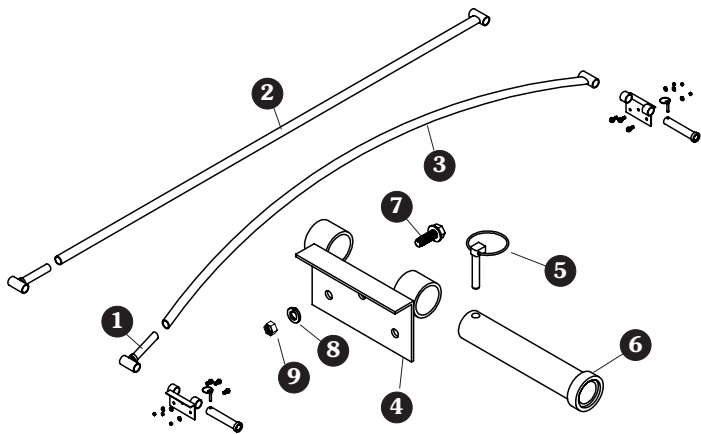

BOWS - HEAVY DUTY

Item	Part #	Description
	1112667	Heavy-Duty Flat Bow Kit
	1106615	Heavy-Duty Low-Rise Bow Kit
	1102697	Heavy-Duty High-Rise Bow Kit
1.	1104706	Heavy-Duty Bow Shank
2.	1112669	Heavy-Duty Flat Bow
3.	1106612	Heavy-Duty Low-Rise Bow
	1101927	Heavy-Duty High-Rise Bow
4.	1106614	Heavy-Duty Bow Bracket
5.	1701098	Lynch Pin - 5/16" x 1 3/4"
6.	1104123	Heavy-Duty Bow Pin
7.	1700400	Self-Tapping Screw - 3/8" x 1"
8.	1700434	Lock Washer - 3/8"
9.	1700407	Hex Nut - 3/8"

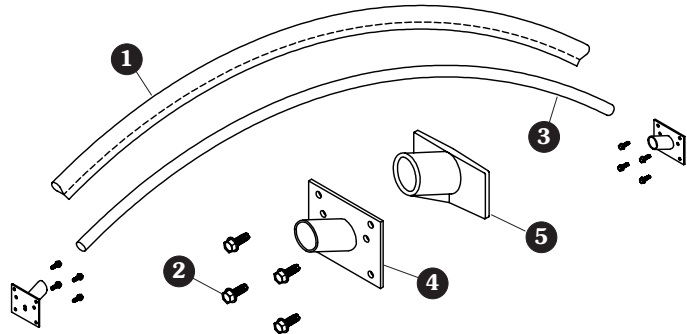

BOWS - DURABOW™

Item	Part #	Description
	1110652	Durabow™ Bow Kit - 97" - Steel Bracket
	1112186	Durabow™ Bow Kit - 102" - Steel Bracket
	1111656	Durabow™ Bow Kit - 97" - Aluminum Bracket
	1112187	Durabow™ Bow Kit - 102" - Aluminum Bracket
1.	1111335	Durabow™ Bow Sock
	1704046	Diamondback Durabow™ Bow Sock (per foot)
2.	1700400	Self-Tapping Screw - 3/8" x 1"
3.	1702625	Durabow™ - 97"
	1702857	Durabow™ - 102"
4.	1110637	Steel Durabow™ Bracket
5.	1704165	Aluminum Durabow™ Bracket

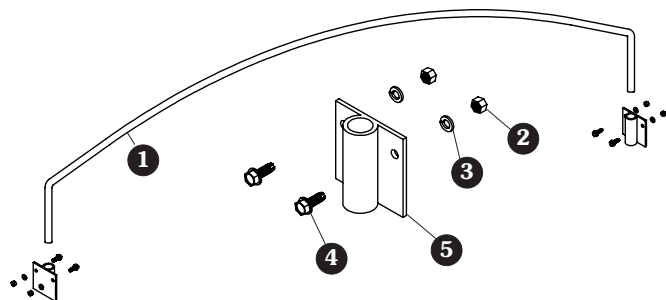

BOWS - ALUMINUM

Item	Part #	Description
1.	*	Solid Aluminum Low-Rise Bow
	*	Solid Aluminum High-Rise Bow
2.	1700407	Hex Nut - 3/8"
3.	1700434	Lock Washer - 3/8"
4.	1700400	Self-Tapping Screw - 3/8" x 1"
5.	1109110	Aluminum Bow Pocket

* Specify size

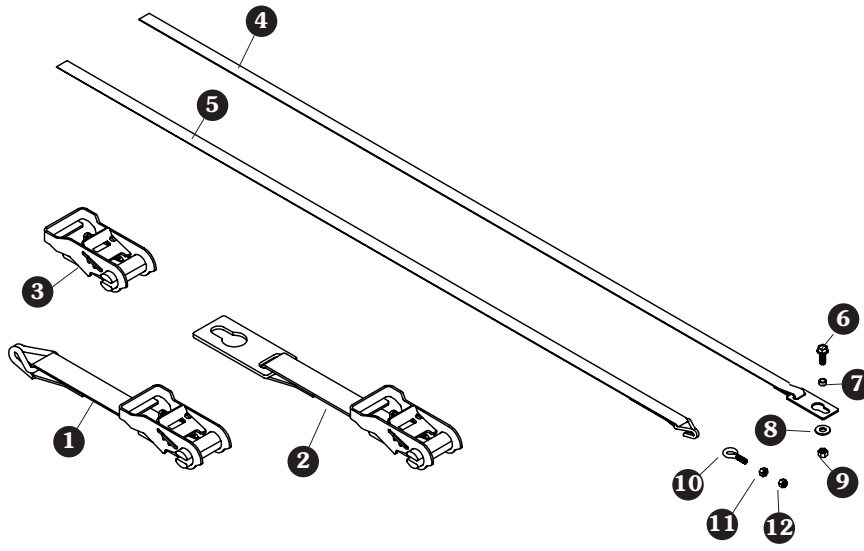

RIDGE STRAPS - 1 INCH

Item	Part #	Description
	1101685	Ridge Strap Kit w/Anchor - 1" x 25'
	1101686	Ridge Strap Kit w/Anchor - 1" x 39'
	1101687	Ridge Strap Kit w/Anchor - 1" x 46'
	1107068	Ridge Strap Kit w/Anchor - 1" x 56'
	1101833	Ridge Strap Kit w/Hook - 1" x 46'
	1120048	Ridge Strap Kit w/Hook - 1" x 25'
	1120454	Ridge Strap Kit w/Hook - 1" x 56'
1.	1106153	Ratchet w/1" Ridge Strap/Hook
2.	1101678	Ratchet w/1" Ridge Strap/Anchor
3.	1700836	Ratchet - 1" Ridge Strap
4.	1101680	Ridge Strap w/Anchor - 1" x 25'
	1101681	Ridge Strap w/Anchor - 1" x 39'
	1101682	Ridge Strap w/Anchor - 1" x 46'
	1107066	Ridge Strap w/Anchor - 1" x 56'
5.	1150222	Ridge Strap w/Hook - 1" x 25'
	1101835	Ridge Strap w/Hook - 1" x 46'
	1116163	Ridge Strap w/Hook - 1" x 56'
6.	1700400	Self-Tapping Screw - 3/8" x 1"
7.	1101683	Anchor Bushing
8.	1701176	Flat Washer - 3/8"
9.	1700418	Centerlock Nut - 3/8"
10.	1700717	Eyebolt Anchor - 5/16"
11.	1700411	Hex Nut - 5/16"
12.	1700419	Nylon Lock Nut - 5/16"

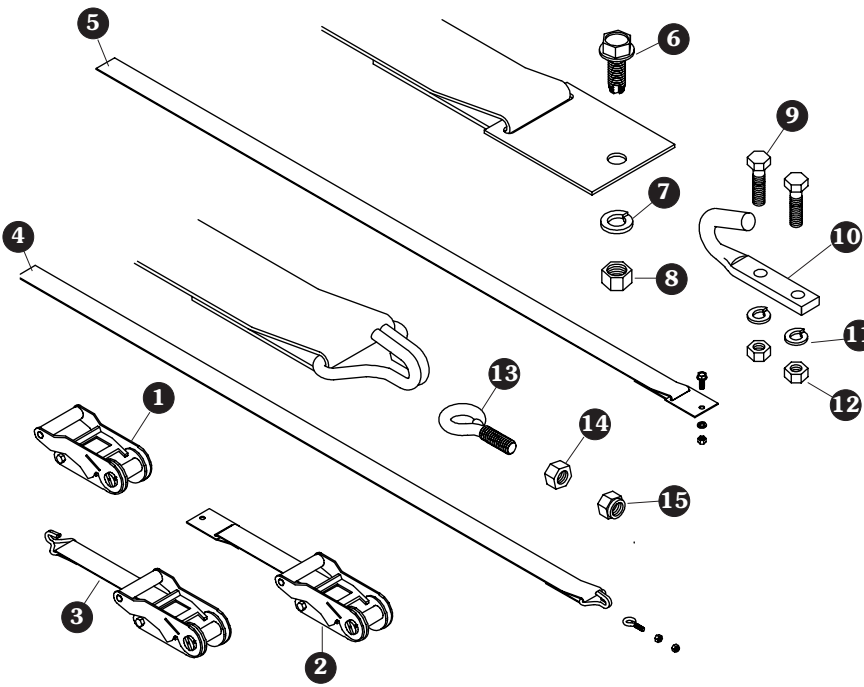

RIDGE STRAPS - 2 INCH

Item	Part #	Description
	1100783	Ridge Strap Kit w/Anchor - 2" x 25'
	1100784	Ridge Strap Kit w/Anchor - 2" x 39'
	1100774	Ridge Strap Kit w/Anchor - 2" x 46'
	1107069	Ridge Strap Kit w/Anchor - 2" x 56'
	1111823	Ridge Strap Kit w/Hook - 2" x 46'
1.	1700519	Ratchet - 2" Web
2.	1100594	Ratchet w/2" Ridge Strap/Anchor
3.	1111818	Ratchet w/2" Ridge Strap/Hook
4.	1111817	Ridge Strap w/Hook - 2" x 46'
5.	1100571	Ridge Strap w/Anchor - 2" x 25'
	1100579	Ridge Strap w/Anchor - 2" x 39'
	1100580	Ridge Strap w/Anchor - 2" x 46'
	1107067	Ridge Strap w/Anchor - 2" x 56'
6.	1700400	Self-Tapping Screw - 3/8" x 1"
7.	1700434	Lock Washer - 3/8"
8.	1700407	Hex Nut - 3/8"
9.	1700381	Cap Screw - 1/4" x 1"
10.	1700682	Box Hook - 5/16" Holes"
11.	1700436	Lock Washer - 1/4"
12.	1700408	Hex Nut - 1/4"
13.	1700717	Eyebolt Anchor - 5/16"
14.	1700411	Hex Nut - 5/16"
15.	1700419	Nylon Lock Nut - 5/16"

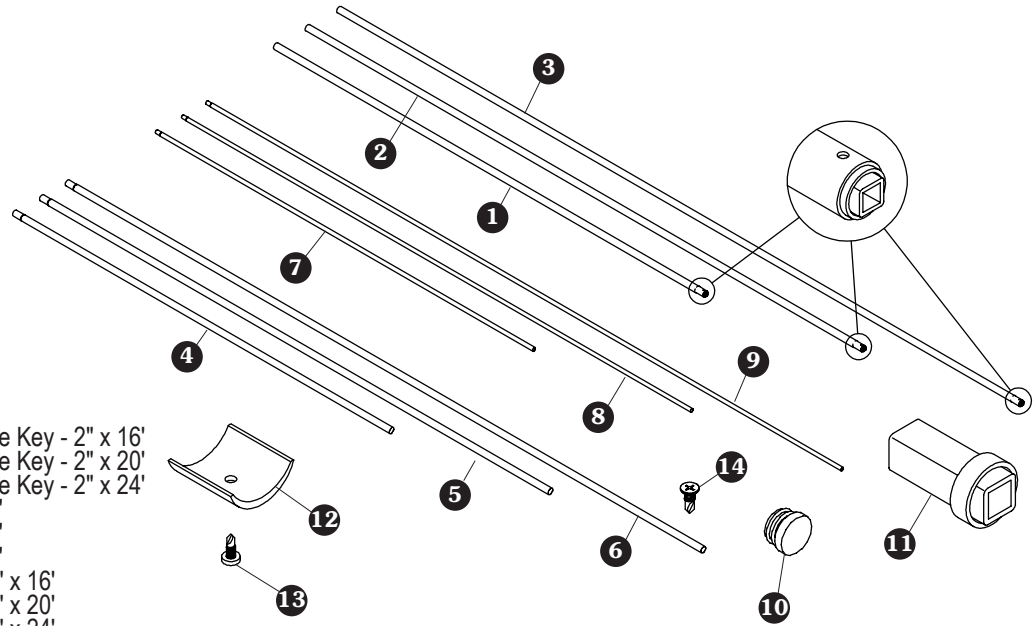

TARP TUBES

Item	Part #	Description
1.	1105132	Roll Tube w/Square Key - 2" x 16'
2.	1105131	Roll Tube w/Square Key - 2" x 20'
3.	1105124	Roll Tube w/Square Key - 2" x 24'
4.	1700048	Roll Tube - 2" x 16'
5.	1700046	Roll Tube - 2" x 20'
6.	1701427	Roll Tube - 2" x 24'
7.	1700051	Fixed Tube - 1 1/8" x 16'
8.	1700049	Fixed Tube - 1 1/8" x 20'
9.	1701428	Fixed Tube - 1 1/8" x 24'
10.	1700523	Plastic End Plug
11.	1105033	Roll Tube Square Key Replacement
12.	1701354	Plastic U-Clamp
13.	1700398	Self-Drilling Screw - 1/4" x 3/4"
14.	1704768	Self-Drilling Screw - 1/4" x 3/4"

TARP STOPS

Item	Part #	Description
	1111092	Standard Tarp Stop Kit
	1111093	Offset Tarp Stop Kit
	1111096	Recessed Tarp Stop Kit
	1111094	Easy-Off Aluminum Tarp Stop Kit
	1111095	Easy-Off Aluminum 6" Offset Tarp Stop Kit
	1114047	Easy-Off Flexible Tarp Stop Kit
	1114388	Easy-Off Flexible 6" Offset Tarp Stop Kit
	1124768	Easy-Off Aluminum Tarp Stop Assembly
	1124771	Easy-Off Aluminum 6" Offset Tarp Stop Assembly
	1114017	Easy-Off Flexible Tarp Stop Assembly
	1114515	Easy-Off Flexible 6" Offset Tarp Stop Assembly
1.	1700729	Protective Cap
2.	1100049	Standard Tarp Stop
3.	1100392	Offset Tarp Stop
4.	1105163	Recessed Tarp Stop
5.	1700400	Self-Tapping Screw - 3/8" x 1"
6.	1700434	Lock Washer - 3/8"
7.	1700407	Nut - 3/8"
8.	1704380	Bowtie Cotter Pin
9.	1115217	Easy-Off Flexible 6" Offset Tarp Stop Upright w/Embedded Safety Plate
10.	1115216	Easy-Off Flexible Tarp Stop Upright w/Embedded Safety Plate
11.	1100833	Easy-Off Tarp Stop Body
12.	1703604	Clevis Pin - 5/16" x 2 7/8"
13.	1705454	Easy-Off Alum. (Cast) 6" Offset Tarp Stop Upright
14.	1705775	Easy-Off Aluminum (Cast) Tarp Stop Upright

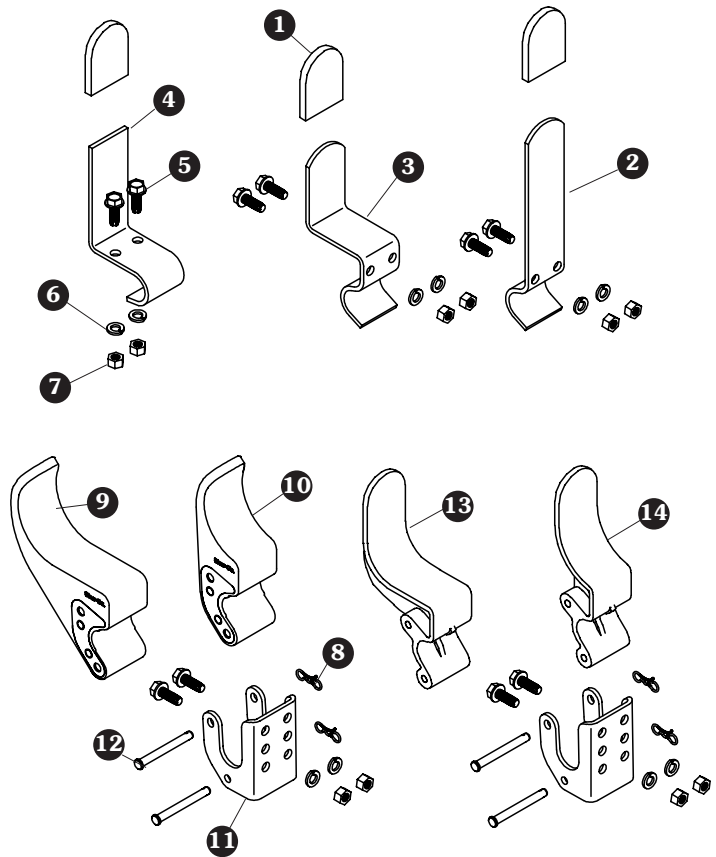

HOLD-DOWNS - BELT 'N RATCHET

Item	Part #	Description
	1106770	Cable Hold-Down Kit - 7'
	1106771	Strap Hold-Down Kit w/Hook - 5'
	1106772	Strap Hold-Down Kit w/Hook - 9'
	1107224	Strap Hold-Down Kit w/Hook - 5'
	1107225	Strap Hold-Down Kit w/Hook - 7'
1.	1106774	Strap Assembly - 9'
2.	1100470	Strap Assembly - 5'
3.	1701354	Plastic U-Clamp
4.	1700398	Self-Drilling Screw - 1/4" x 3/4"
5.	1107223	Wire Hook Strap Assembly - 7'
6.	1107222	Wire Hook Strap Assembly - 5'
7.	1106763	Cable Assembly w/Hook - 7'
8.	1100457	Ratchet - 2"
9.	1700400	Self-Tapping Screw - 3/8" x 1"
10.	1700434	Lock Washer - 3/8"
11.	1700407	Nut - 3/8"
12.	1106754	Web Assembly w/Hook

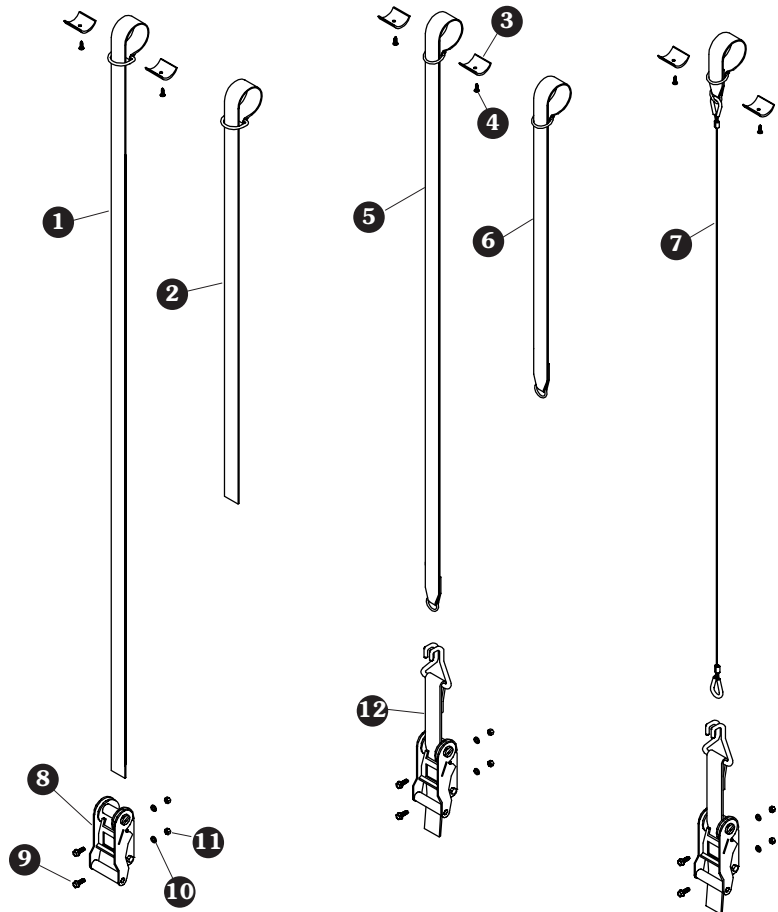

CRANK ARMS - STANDARD

Item	Part #	Description
	1100061	Standard Belt 'n Ratchet Crank Arm Kit
	1101500	Long Belt 'n Ratchet Crank Arm Kit
1.	1115774	Pilot Crank Key
2.	1700527	Econo U-Joint
3.	1700445	Spring Pin - 1/4" x 1 1/2"
4.	1100461	Offset Crank Arm
5.	1107838	Square Crank Extension - 33"
6.	1701118	Spring Pin - 1/4" x 1 3/16"
7.	1700526	Wire Lock Pin - 3/8" x 2 1/2"

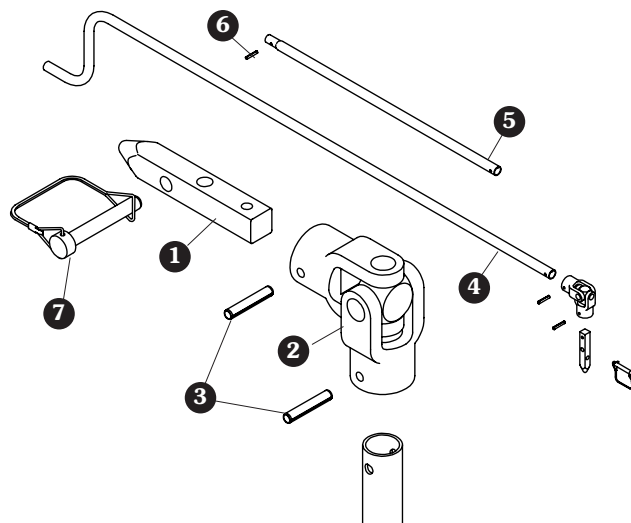

CRANK RETAINERS

Item Part # Description

- 1100386 Crank Retainer Kit w/7" Standoff
- 1100388 Crank Retainer Kit w/2" Standoff
- 1107047 Pinless Crank Retainer Kit w/7" Standoff
- 1107048 Pinless Crank Retainer Kit w/2" Standoff
- 1107052 Pinless Crank Retainer Conversion Kit
- 1101929 Offset Crank Retainer Kit
- 1114603 Offset Pinless Crank Retainer Kit
- 1114602 Offset Pinless Crank Retainer Conversion Kit
- 1115515 Stainless Pinless Crank Retainer Kit w/7" Standoff
- 1115516 Stainless Pinless Crank Retainer Kit w/11" Standoff
- 1. 1700407 Nut - 3/8"
- 1200999 Stainless Nut - 3/8"
- 2. 1700434 Lock Washer - 3/8"
- 1703576 Stainless Lock Washer - 3/8"
- 3. 1100574 Cable w/#5 Interlock Snap
- 4. 1700400 Self-Tapping Screw - 3/8" x 1"
- 1703579 Stainless Cap Screw - 3/8" x 1"
- 5. 1700526 Wire Lock Pin - 3/8" x 2 1/2"
- 6. 1101930 Offset J-Hook
- 7. 1114599 Offset Pinless Crank Retainer Base Plate
- 8. 1703134 Tension Spring
- 9. 1114600 Offset Pinless Crank Retainer Lock
- 10. 1703133 Clevis Pin - 5/16" x 1 3/4"
- 11. 1704380 Bowtie Cotter Pin - 1 3/8"
- 12. 1700427 Flat Washer - 1/4"
- 13. 1100306 Retainer Bushing - 11/16"
- 14. 1100040 J-Hook Crank Retainer
- 15. 1107049 Pinless Crank Retainer
- 1115514 Stainless Pinless Crank Retainer
- 16. 1702996 Cap Screw - 1/2" x 1 1/4"
- 1703619 Stainless Cap Screw - 1/2" x 1 1/4"
- 17. 1100137 Crank Retainer Standoff - 2"
- 18. 1107080 Crank Retainer Standoff - 3"
- 19. 1100033 Crank Retainer Standoff - 7"
- 20. 1109478 Crank Retainer Standoff - 11"
- 21. 1115511 Stainless Crank Retainer Standoff - 7"
- 22. 1115513 Stainless Crank Retainer Standoff - 11"
- 23. 1703620 Stainless Flat Washer - 1/2"
- 24. 1703577 Stainless Flat Washer - 3/8"

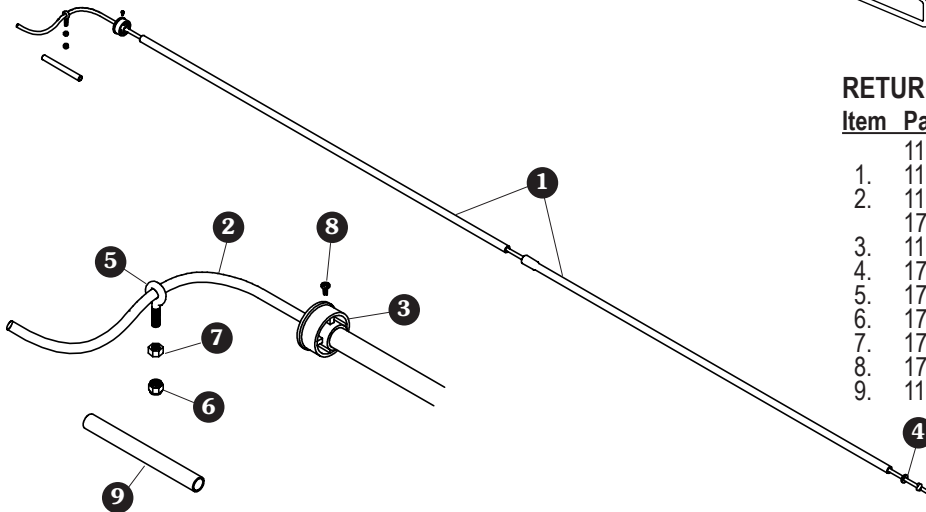
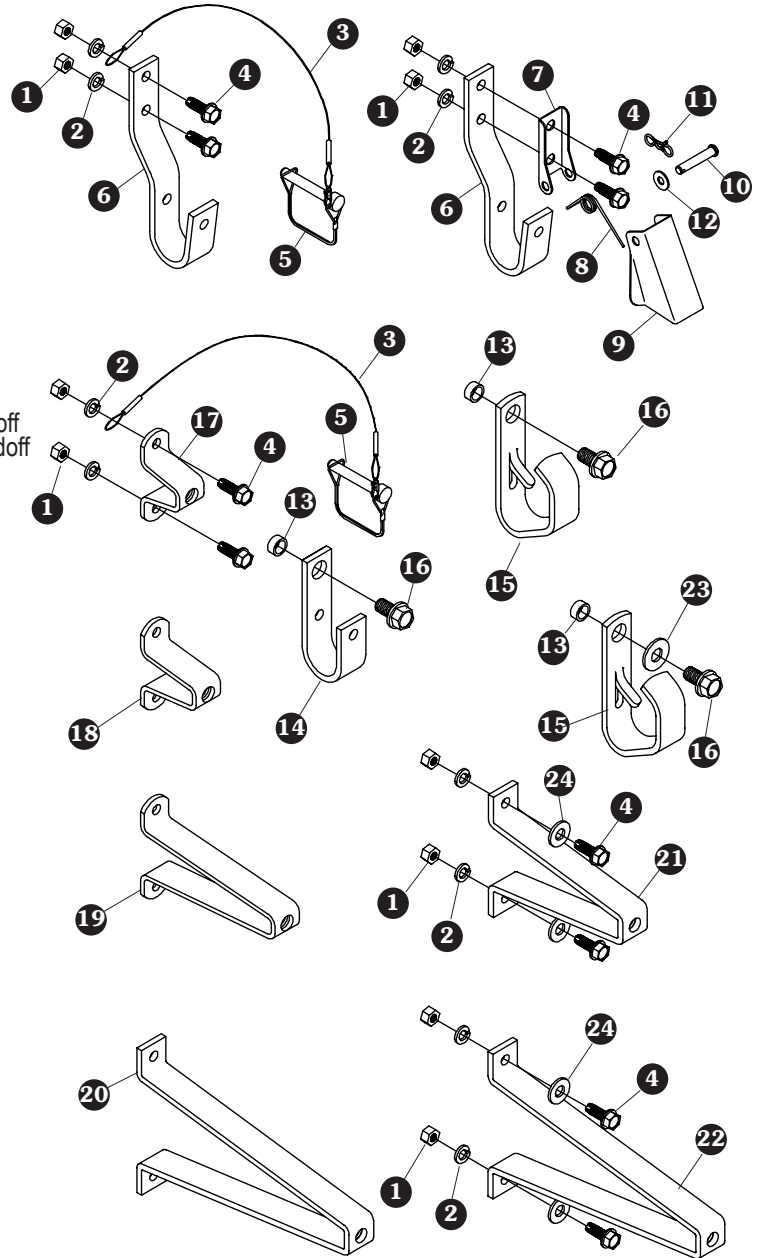

RETURNS - STRETCH CORD

Item Part # Description

- 1114359 Front Stretch Cord Roll Return Kit
- 1. 1111067 Roll Return Tube Set - 2 Pc.
- 2. 1114360 Roll Return Stretch Cord - 11 1/2'
- 1703335 Roll Return Stretch Cord - 300'
- 3. 1100138 Nylon End Plug
- 4. 1703373 Flat Washer - 1/2"
- 5. 1700717 Eyebolt Anchor - 5/16"
- 6. 1700419 Nylon Lock Nut - 5/16"
- 7. 1700411 Nut - 5/16"
- 8. 1704743 Self-Drilling Screw - #10 x 1/2"
- 9. 1107680 Protective Stretch Cord Cover

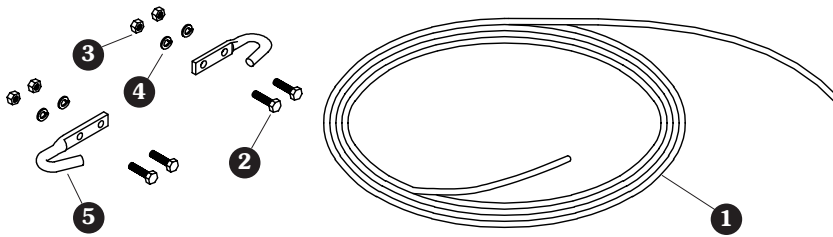

RETURNS - ROPE

Item	Part #	Description
	1100064	Rope Return Kit
1.	1100469	Rope - 32'
2.	1700381	Cap Screw - 1/4" x 1"
3.	1700408	Nut - 1/4"
4.	1700436	Lock Washer - 1/4"
5.	1700682	Box Hook - 5/16" Holes

OPTIONS & UPGRADES

BOW COVERS

Vinyl-coated compound wraps over bows and clips underneath with U-clips. Reduces tarp wear and grain splatter, prevents rust and provides traction. Extra-wide bow covers also available.

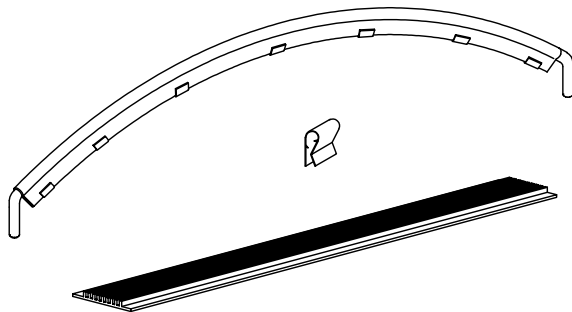

ROLL TUBE DEFLECTOR

Fasten to latchplate side of trailer to keep roll tube from damaging paint job. Fasten with 5/16" self-tapping screws.

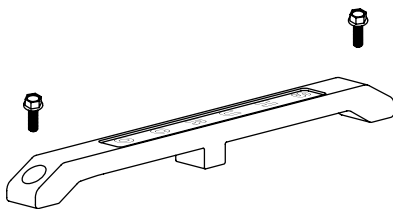

TURNING POINT™ BOWS

Operated from the ground, Turning Point™ bows easily swing aside with just a pull of a rope. Bows latch securely when closed.

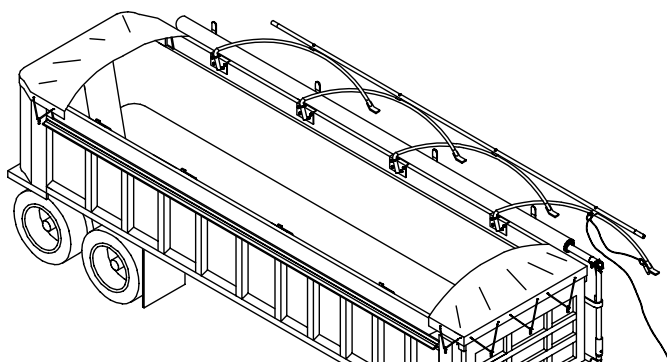

STANDARD TARP REPAIR KIT

Shur-Co's standard tarp repair kit comes complete with adhesive, cleaner, 10 sq. ft. of tarp material (specify color) and instructions.



PROFESSIONAL TARP REPAIR KIT

Shur-Co's professional tarp repair kit repairs your tarp using the heat-seal method. No messy adhesives or solvents. This kit includes heat gun, scissors, roller, 12' of 18-oz. or 22-oz. repair tarp (specify color) and instructions.



TARP OPTIONS

22-oz. heavy-duty fabric, multicolored tarps, personalized tarps, reinforcements, extra length or width and 13 vibrant colors available.

MORE QUALITY PRODUCTS FROM SHUR-CO®

- **Genuine Replacement Tarps**
- **Genuine Replacement Parts**

- **Agriculture Products**
 - *The Original Shur-Lok®*
 - **Turning Point™ Bow**
 - **Shur-Lok® Junior**
 - **Premium Belt 'n Ratchet**
 - **Cable-Lok™**
 - **Tater-Top™**

- **SMARTrailer™ Accessories for Agriculture Products**
 - **SMART2™ Remote**
 - **SMART3™ Remote**
 - **4500 Series HD Electric**
 - **Electric Shur-Lok®**
 - **AutoTrap™ Hopper Opener**
 - **ProTrap® Hopper Opener**
 - **Electric Gate & Hoist**
 - **DriveMaxx™ Auger Drive**
 - **Electric Farm Swing Gate**
 - **LiteALL™ Work Lights**
 - **Cable-Lok™ Electric Upgrade**
 - **Electric Turning Point™ Bow**
 - **Solar Power Pack**

- **Construction Products**
 - *The Original Shur-Lok®*
 - **Turning Point™ Bow**
 - **Shur-Trak II™**
 - **IronSide II™**
 - **Shur-Matic™**

- **SMARTrailer™ Accessories for Construction Products**
 - **4500 Series HD Electric w/Gate Flex™**
 - **Shur-Trak II™ Electric Upgrade**
 - **Electric Turning Point™ Bow**
 - **Solar Power Pack**

- **Custom Products**
 - **Fitted Truck Covers**
 - **Flat Utility Tarps**
 - **Bean Drill Covers**
 - **Gustbuster™ Tarp Cords**
 - **SMARTwire™**

TARPING SYSTEMS & ACCESSORIES

