

Item	Part #	Description
1.	1109444	Motor Mount Shim
2.	1109449	Motor Mount Base Plate
3.	1701054	Bearing Flange
4.	1106619	Sprocket - 18 Tooth
5.	1702594	Ball Bearing - 1"
6.	1109445	Motor Mount Shaft
7.	1109443	Motor Mount Cover Plate
8.	1109452	Motor Mount
9.	1701498	Super-Duty Electric Motor
10.	1704878	Durabuilt Motor W/Cover - 3 1/8" Shaft
11.	1109456	Roller Chain w/Link - 22 3/4"
12.	1701057	Connector Link
13.	1701056	Square Key
A.	1700398	Self-Drilling Screw - 1/4" x 3/4"
B.	1701522	Carriage Bolt - 5/16" x 1"
C.	1701493	Socket Hd. Cap Screw - 5/16" x 1 1/2"
D.	1701468	Cap Screw - 5/16" x 1 3/4"
E.	1700400	Self-Tapping Screw - 3/8" x 1"
F.	1700433	Lock Washer - 5/16"
G.	1700428	Flat Washer - 5/16"
H.	1700429	Flat Washer - 3/8"
J.	1700411	Hex Nut - 5/16"
K.	1700407	Hex Nut - 3/8"

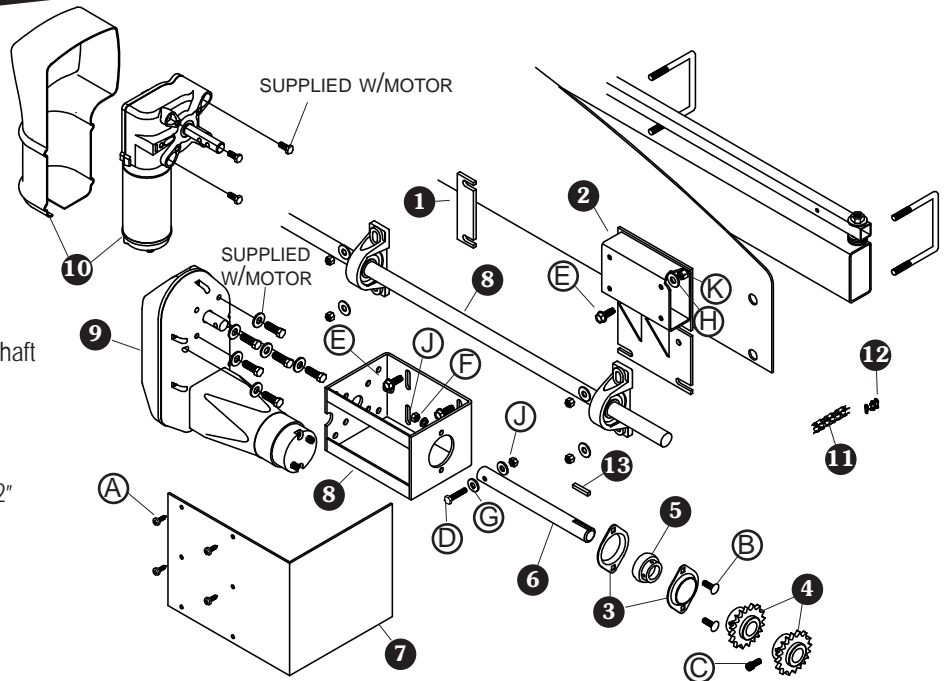

**STEP 1:** Loosen driver side bearing on front drive assembly. Slide base plate behind bearing. Square up mount and retighten bearing.

**STEP 2:** Install screw **E** through hole in base plate.

**STEP 3:** Install and secure motor mount shims behind center and passenger side bearings.

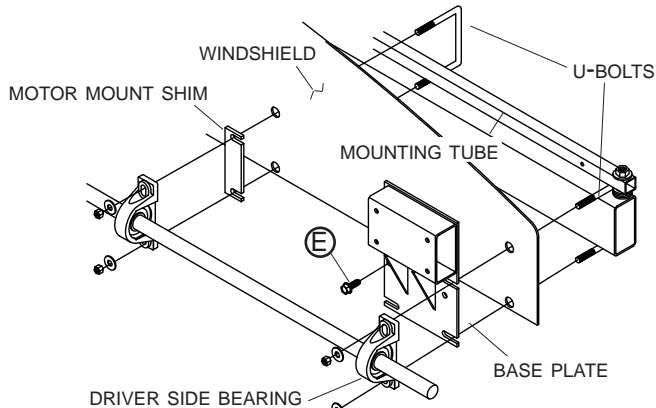

**STEP 4:** Fasten motor mount to base plate with screws **E**, washers **F** and nuts **K**. Finger tighten.

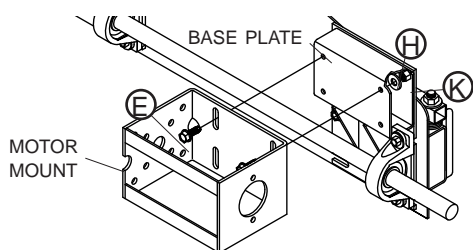

**STEP 5:** Fasten electric motor to motor mount with supplied screws and washers.

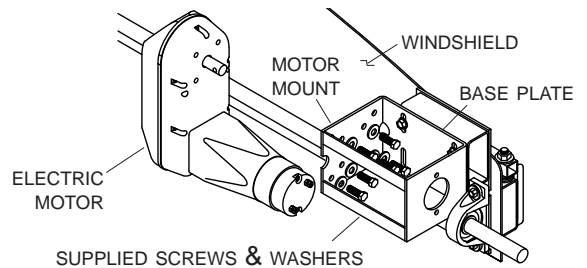

**STEP 6:** Install motor shaft with cap screw **D**, nut **J** and washers **G**.

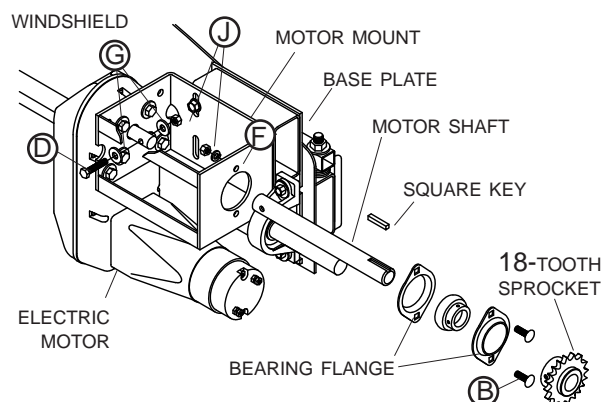

**STEP 7:** Install bearing and bearing flanges with screws **E**, nuts **I** and washers **F**.

**STEP 8:** Slide 18-tooth sprocket over drive shaft. Do not tighten set screw until step 10.

**STEP 9:** Remove existing sprocket or pulley (used in manual operation). Replace with 18-tooth sprocket. Fasten with screw **C**.

REMOVE EXISTING SPROCKET OR PULLEY

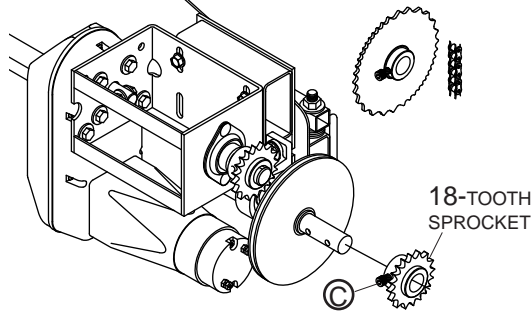

**STEP 10:** Lay chain over top of sprockets and adjust sprocket on motor mount shaft so chain runs straight. Tighten set screw on sprocket against flat on motor shaft.

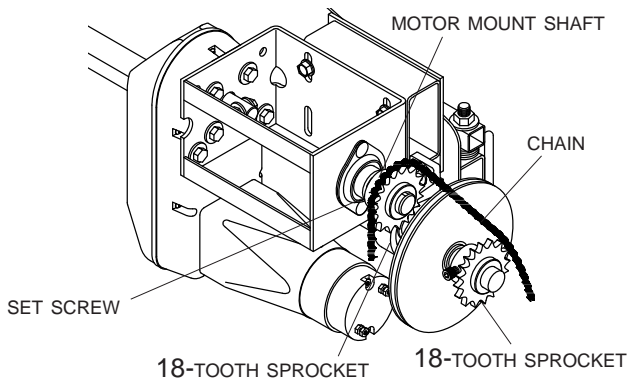

**STEP 11:** Wrap chain around sprockets. Connect with connector link. Create tension on chain by pulling motor assembly upwards. Square assembly with base plate and remove slack in chain. Tighten nuts **K**.

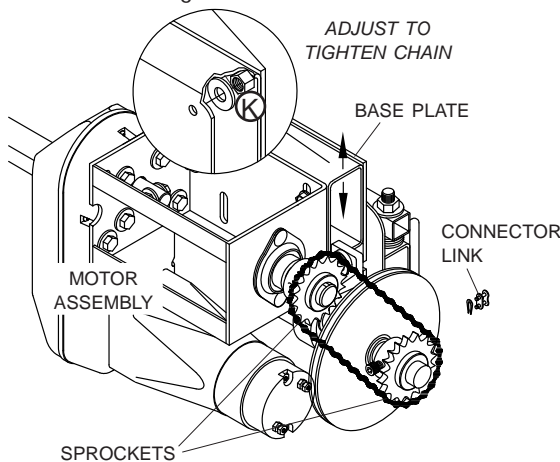

**NOTE:** Sprockets must remain parallel so chain will run straight.

**STEP 12:** Install cover plate with screws **A**.

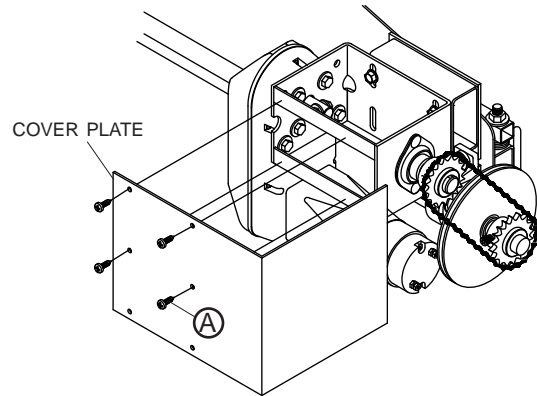

**ELECTRIC MOTOR WIRING**

**STEP 13:** Run 6-ga. wire from motor to solenoid and from power supply to solenoid as shown in diagram. Run 14-ga. wires from solenoid to switch. Locate switch in a convenient operating location.

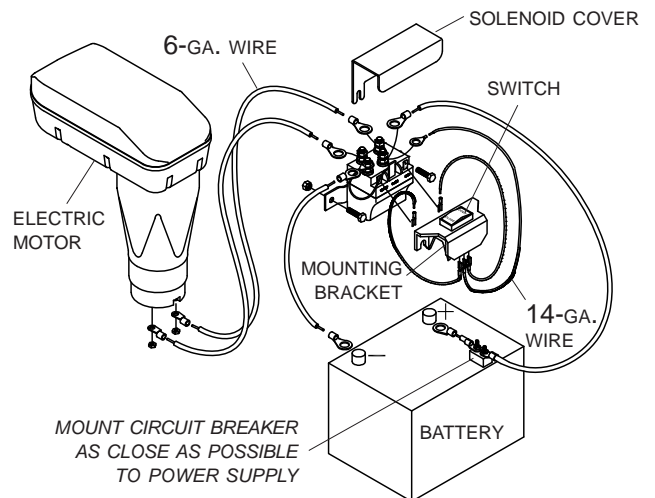

**NOTE:** System can only be grounded through switch. Running wires to motor will reverse continuity.

