



TARPING SYSTEMS & ACCESSORIES

P/N 1117010 Rev. Z

OWNER'S MANUAL



Aluminum System for Semi - Grain Trailer

READ BEFORE INSTALLING

PO BOX 713 ■ 2309 SHUR-LOK STREET ■ YANKTON, SD 57078-0713
PHONE 1-800-4-SHUR-LOK (1-800-474-8756) ■ FAX 605-665-0501
www.shurco.com

SHOP ONLINE: www.shopshurco.com

SHIPPING. Orders are shipped F.O.B. from the Shur-Co®, LLC sites listed below. No full freight is allowed or prepaid shipment accepted unless quoted and approved in writing prior to acceptance of the order. All shipments are made by the most reasonable means in accordance with size and weight of order, unless specified routing instructions are furnished by the customer. Shipments are made daily via U.P.S. and common carrier. Claims for shortages must be made within 10 days. All claims for damages or loss in transit must be made with the carrier. No collect calls will be accepted. To ensure delivery of orders, we need your full street address and phone number. When you receive your shipment, examine it carefully. Be sure all cartons listed on the delivery sheet are accounted for. Large items may be packaged separately. If a carton is damaged, open it and inspect the contents before signing for delivery. If merchandise is damaged, describe damage on the delivery receipt. Failure on your part to document damaged or missing merchandise on the delivery receipt releases the carrier of all liability; repair or replacement will be the customer's responsibility.

WARRANTY. We warrant all new products are free of defects in materials and workmanship.* This warranty is effective if products are properly installed and used for the purpose for which they were intended and applies to the original buyer only. Except as set forth above or in any product-specific warranty documentation, we make no other warranties, express or implied, including but not limited to warranties of merchantability of fitness for a particular use.

Returns of a product for warranty must be accompanied by a Return Merchandise Authorization number (RMA#), obtained by calling Customer Service at 866-748-7435, and sent, with freight paid by us, to Shur-Co®, LLC, 2309 Shur-Lok St., PO Box 713, Yankton, SD 57078. All products returned without an RMA# will be refused. When we issue the RMA#, we will also issue a call tag to have UPS (or other freight company) pick up the product. C.O.D. returns not accepted. We will pay no storage fees for a warranty product return prior to pick by us or the freight company. If a warranty product return is scheduled to be picked up by us, we will pick up the product at our earliest convenience.

If a product returned is found, in our judgement, to be defective in material or workmanship, our obligation under this warranty is limited to the repair or replacement of the product, which will be made by us. Repair or replacement will be at our discretion, with replacements being made using current products performing in the equivalent function. Labor charges, other than those incurred at our factory, including, but not limited to, any labor to install a repaired or replacement product, are not covered under this warranty. All expenses associated with delivering defective products to our factory and delivering repaired or replacement products from our factory to the owner will be paid by us.

If the product returned is found, in our judgement, to be non-warrantable, the owner will be contacted to authorize repair work, purchase of a replacement product or return of the product, all of which will be at the owner's expense. Payment authorization must be received by us before any non-warrantable product is repaired, replaced or returned. All expenses associated with delivering the repaired non-warrantable product, a replacement product or the non-warrantable product from our factory to the owner will be paid by the owner.

In no event will we be liable for any damages of any kind to person, product or property, including but not limited to indirect, incidental, special, consequential or punitive damages, or damages for loss of profits or revenue, even if we have been advised of the possibility of such damages. There are no warranties for used products or products that have been repaired, altered, modified or subjected to misuse, negligence or accident. We will not repair or replace products that fail or malfunction due to ordinary wear and tear, except as expressly noted in a product-specific warranty. Use of non-Shur-Co®, LLC parts in conjunction with Shur-Co®, LLC products will void this product warranty.

*Certain products have specific warranties that differ from this warranty, for example motors and electronics. Product-specific warranty documentation is available for these items. In the event of a conflict between this warranty and a product-specific warranty, the product-specific warranty will govern.

RETURN POLICY. All sales final. See WARRANTY above for return details.

OTHER. All prices, product listings, sizes, weights and manufacturing details are subject to change without notice. No person is authorized to modify the foregoing conditions of sale whatsoever.

SHUR-CO®, LLC SERVICE AND DISTRIBUTION CENTERS

Corporate HQ and Outlet Store

SHUR-CO® of SOUTH DAKOTA
2309 Shur-Lok St., PO Box 713
Yankton, SD 57078-0713
Ph 800.474.8756 | Fax 605.665.0501

ShurTite™ Service Centers

SHUR-CO® of CANADA
490 Elgin St., Unit #1
Brantford, Ontario N3S 7P8
Ph 800.265.0823 | Fax 519.751.3997

SHUR-CO® of SIOUX FALLS
47184 258th St., Suite B
Sioux Falls, SD 57107
Ph 844.573.9322 | Fax 605.543.5469

SHUR-CO® of ILLINOIS
Ph 866.356.0246 | Fax 217.877.8270

SHUR-CO® of OHIO
Ph 866.356.0242 | Fax 330.297.5599

SHUR-CO® of COLORADO
10220 Brighton Rd., Unit #1
Henderson, CO 80640
Ph 866.355.9173 | Fax 303.289.2298

SHUR-CO® of FLORIDA
3353 SE Gran Park Way
Stuart, FL 34997
Ph 800.327.8287 | Fax 772.287.0431

SHUR-CO® of ILLINOIS
3993 E. Mueller Ave.
Decatur, IL 62526
Ph 866.356.0246 | Fax 217.877.8270

SHUR-CO® of IOWA
3839 Midway Blvd.
Ft. Dodge, IA 50501
Ph 866.356.0245 | Fax 515.576.5578

SHUR-CO® of MICHIGAN
5100 Lakeshore Dr.
Lexington, MI 48450
Ph 800.327.8287 | Fax 772.287.0431

SHUR-CO® of NORTH DAKOTA
1746 4th Ave. NW
West Fargo, ND 58078
Ph 877.868.4488 | Fax 701.277.1283

SHUR-CO® of OHIO
1100 N. Freedom, St. Rt. 88 & 14
Ravenna, OH 44266
Ph 866.356.0242 | Fax 330.297.5599

SHUR-CO® of TEXAS
34505 I-10 West, S. Frontage Rd.
Brookshire, TX 77423
Ph 866.689.0039 | Fax 281.934.3311

SHUR-CO® UK, Ltd.
Unit 41 Rochester Airport Estates
Laker Rd., Rochester, Kent ME1 3QX
Ph +44 (0)1795.473499
Fax +44 (0)871.272.8278

For more info, log on to our website:
www.shurco.com

MESSAGE TO OWNERS

Thank you for buying this tarping system from Shur-Co®. We appreciate your confidence in our products. Please read and thoroughly understand this manual before installing and/or operating this system.

Pay particular attention to important safety and operating instructions, as well as warnings and cautions. The hazard symbol  is used to alert users to potentially hazardous conditions and is followed by caution, warning or danger messages.

Failure to READ AND FOLLOW INSTRUCTIONS could result in failure of your tarping system and/or personal injury. Your trailer requirements may, however, call for minor variations to these instructions.

Please inspect your tarping system periodically. Repair or replace worn or damaged parts to your system.

QUESTIONS? CALL OUR HELP LINE:

1-866-748-7435

MON-FRI 8 AM-5 PM CENTRAL TIME

TABLE OF CONTENTS

Hardware Identification..... 1
 Pivot Bracket Installation Front & Rear.....2-7
 Pivot Bracket Installation 8
 Universal Pivot Bracket Installation Vertical Trailer 9
 Front Flex Arm & Electric Motor Installation 10-11
 Rear Flex Arm Installation 12-13
 Roll Tube Extension Installation 14-16
 Electric Mounting & Wiring 17-20
 Wireless SMARTransmitter® Programming & Operating 21
 Program Wireless SMARTransmitter® to Receiver 22
 Change to Manual Power 23
 Reverse Roll Pivot Bracket Installation Front & Rear 24-26
 Reverse Roll Front Flex Arm & Electric Motor Installation 27-28
 Reverse Roll Rear Flex Arm Installation..... 29-30
 Replacement Parts 31-34
 Troubleshooting Guide 35

SAFETY

We at Shur-Co® are concerned with your safety and the safety of all those operating this system. Therefore, we have provided safety decals at various locations on your tarping system. Keep decals as clean as possible at all times. Replace any decal that has become worn or damaged, painted over or otherwise difficult to read. Replacement decals are available through Shur-Co® dealers.

SAFETY INSTRUCTIONS

- 1. Always wear safety glasses during installation and operation.**
- 2. Stay clear of moving parts.**
- 3. No other use of this system is authorized, except as designed.**

RUST PREVENTION

To prevent rust, paint all exposed metal, such as weld seams and/or metal exposed by grinding or cutting, with corrosion-resistant paint.

TOOLS REQUIRED

1. Welder
2. Hammer
3. Center Punch or Transfer Punch
4. #3 Phillips Insert Bit
5. Air or Electric Impact Wrench (9/16" deep socket)
6. 7/16" Deep Socket
7. 3/8" Combination Wrench
8. 9/16" Combination Wrench
9. 1/2" Combination Wrench
10. 1/8" Hex Wrench Long T-Handle
11. 3/16" Hex Wrench Long T-Handle (recommended)
12. 5/16" Drill Bit (for 3/8" self-tapping screws)
13. 11/32" Drill Bit
14. 13/32" Drill Bit
15. 3/8" Drill
15. 1 1/8" Hole Saw
16. 2" Hole Saw (if bracket for conductor socket is not used)
17. Standard/Flathead Screwdriver
18. #2 Phillips Screwdriver
19. Utility Knife
20. Ratchet
21. Hack Saw (metal cutter)
22. Pliers
23. Snap Ring Pliers
24. Wire Cutters
25. Grinder
26. Tape Measure

Inspect all parts in your 3500 Series Electric kit upon arrival.

A



1704353 Self-Drilling Screw - 1/4" x 1"

B



1700381 Cap Screw - 1/4" x 1"

C

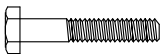

1700377 Cap Screw - 1/4" x 1 1/2"

D



1702672 Cap Screw - 1/4" x 2 1/4"

E



1701045 Cap Screw - 5/16" x 3/4"

F



1703284 Button Hd. Cap Screw - 5/16" x 7/8"

G



1702926 Cap Screw - 5/16" x 7/8"

H



1703487 Cap Screw - 5/16" x 1 1/2"

J

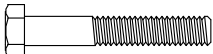

1701420 Cap Screw - 5/16" x 2"

K



1700400 Self-Tapping Screw - 3/8" x 1"

L



1702891 Cap Screw - 3/8" x 1 1/4"

N



1201022 Cap Screw - 5/16" x 3 1/2"

O



1701543 Nylon Lock Nut - 1/4"

P



1700411 Hex Nut - 5/16"

Q



1700419 Nylon Lock Nut - 5/16"

R



1702492 Top Lock Nut - 5/16"

S



1700407 Hex Nut - 3/8"

T



1700427 Flat Washer - 1/4"

V

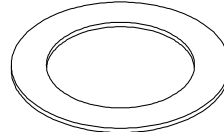

1702890 Flat Washer - 1 1/4"

W



1700428 Flat Washer - 5/16"

Y



1700434 Lock Washer - 3/8"

Z



1700429 Flat Washer - 3/8"

AA

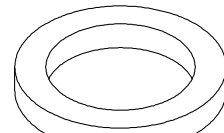

1118318 Spacer Washer - 1/4" x 1.81"

BB



1120291 Pivot Bracket Washer

NOTE: For reverse roll option see pages 24 to 26.

NOTE: Read pages 2 and 3 entirely before drilling holes.

Determine if rivets are centered or off center on front and rear of trailer.

FRONT OF TRAILER

STEP 1: Locate front pivot mount bracket on passenger side of trailer so that center of pivot lies within shaded area shown below. Measure 42" down from top of cap or 44" from top of windshield.

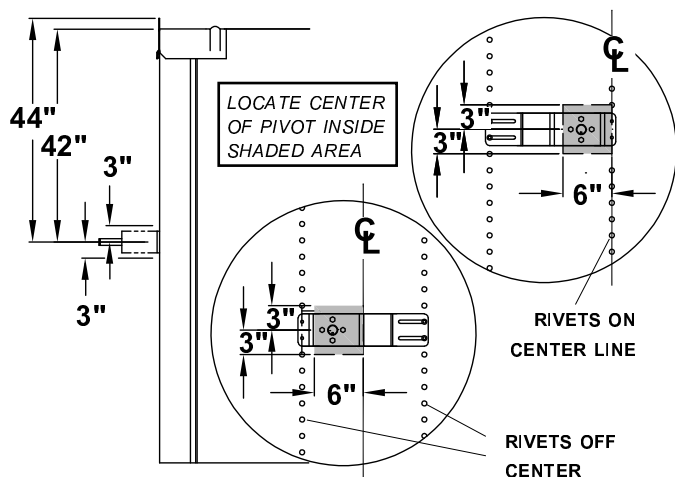

REAR OF TRAILER

STEP 2: Locate rear pivot mount bracket so that center of pivot lies within shaded area shown below.

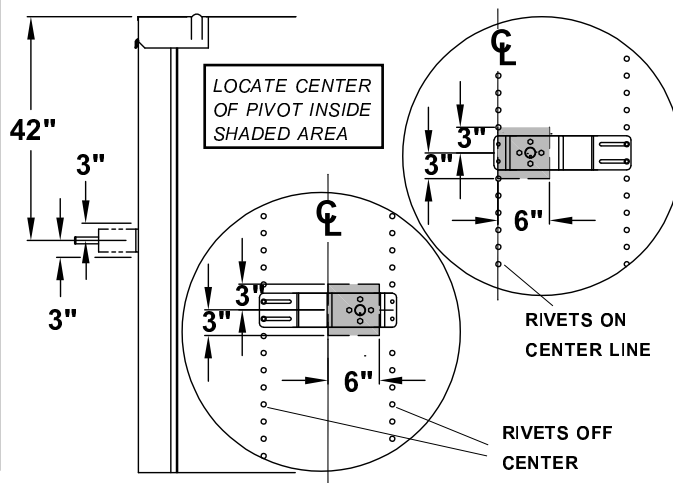

NOTE: Mount brackets into support braces on trailer if possible. If bracket cannot be mounted into support braces, reinforce mounting area with backer plate for adequate support. Before drilling any holes, make sure flex arm has a clear pathway to operate.

INSTALL BRACKETS ON HORIZONTALLY CORRUGATED TRAILERS

NOTE: Use pivot bracket washers **333** only when horizontal corrugation on trailer skin prevents bracket from contacting trailer skin.

STEP 1: If installing pivot bracket or pivot mount bracket on horizontally corrugated trailer skin, center bracket between corrugations and use brackets as a guide to mark hole locations. Mark and drill 13/32" holes in trailer and fasten with 3/8" x 1 1/4" cap screws, flat washers, lock washers, pivot bracket washers and nuts. Locate pivot bracket washers between pivot bracket and trailer skin as shown.

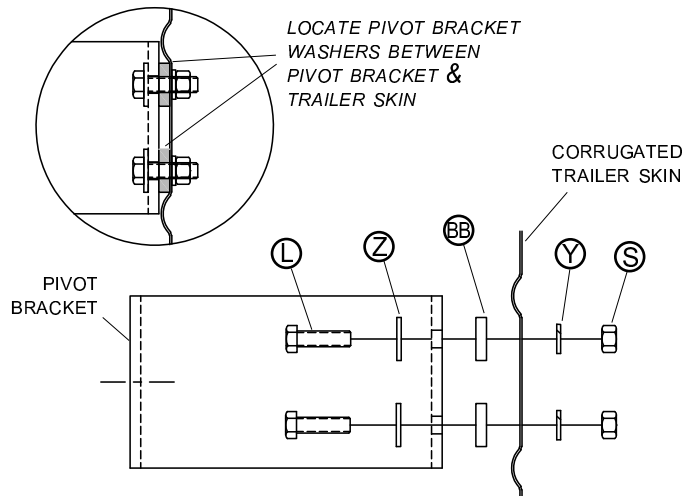

STEP 3: Place pivot mount brackets on trailer in orientation shown below. Using brackets as a guide, mark mounting hole locations.

FRONT OF TRAILER

RIVETS/CORRUGATION ON CENTER

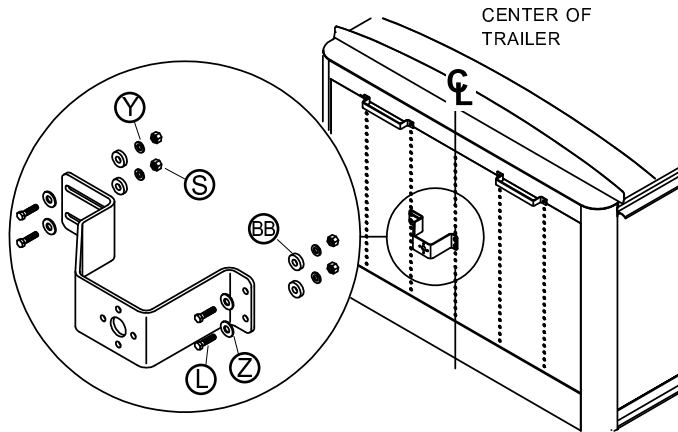

RIVETS /CORRUGATION OFF CENTER

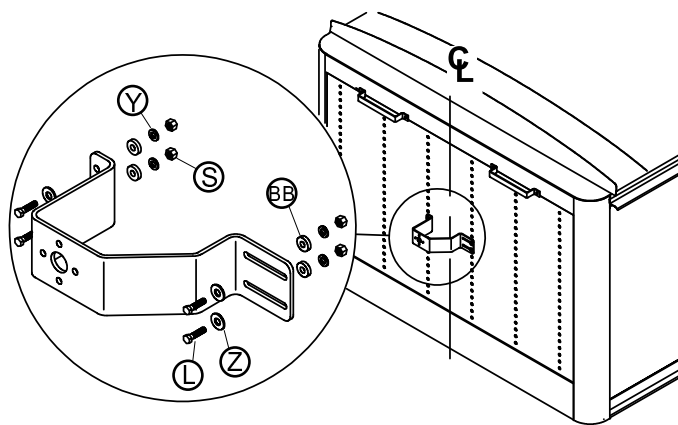

REAR OF TRAILER

RIVETS/CORRUGATION ON CENTER

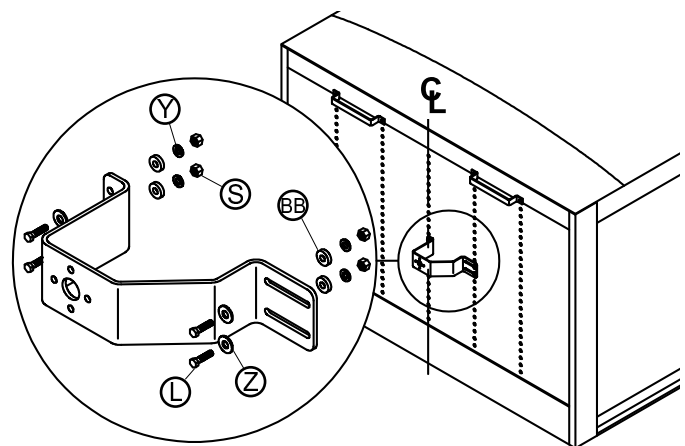

RIVETS/CORRUGATION OFF CENTER

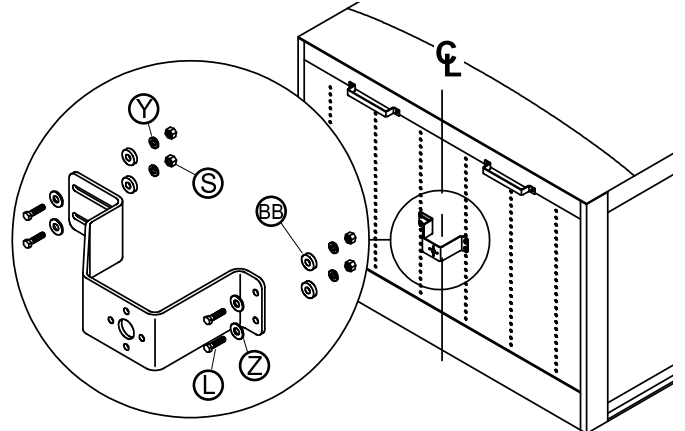

STEP 4: Remove rivets and mount brackets into rivet holes. If this is not possible, drill 13/32" holes in trailer. Fasten with 3/8" x 1 1/4" cap screws, flat washers, lock washers and nuts.

NOTE: Read entire page before drilling holes. Determine if ribs are centered or off center on front and rear of trailer.

NOTE: Use pivot bracket washers **333** only when horizontal corrugation on trailer skin prevents bracket from contacting trailer skin (see instructions on page 2).

FRONT OF TRAILER

STEP 1: Locate sloped pivot mount bracket 42" down from top of cap or 44" from top of windshield, measuring vertically as shown. Do not measure along slope of trailer.

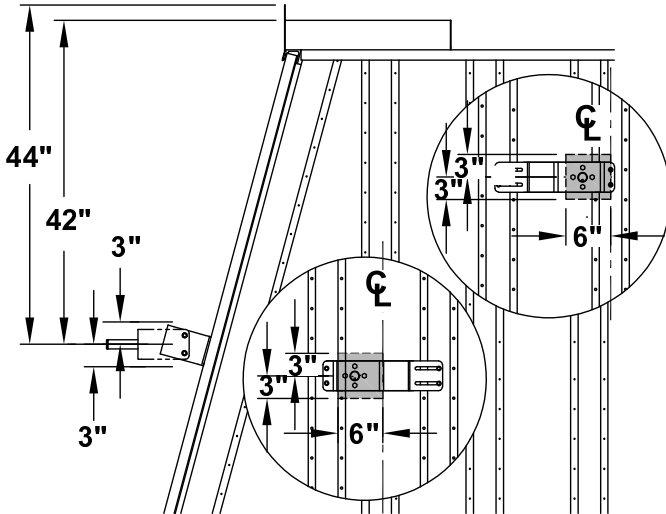

REAR OF TRAILER

STEP 2: Locate sloped pivot mount bracket 42" below top of cap, measuring vertically as shown. Do not measure along slope of trailer.

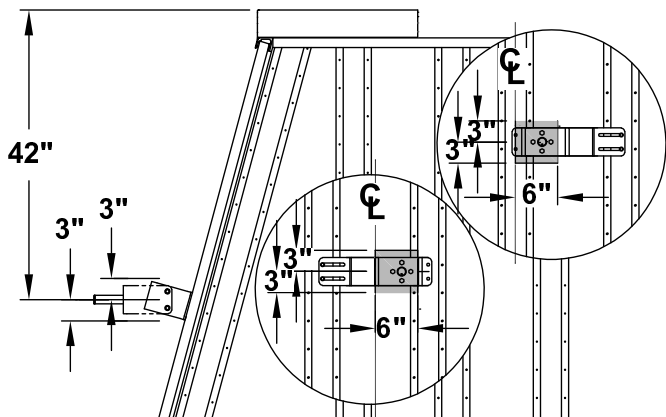

NOTE: Mount brackets into support braces on trailer if possible. If bracket cannot be mounted into support braces, reinforce mounting area with backer plate for adequate support. If bracket does not sit flush with skin of trailer, install spacers between mounting bracket and skin of trailer to assure solid contact through support braces or backer plate.

Before drilling any holes, make sure flex arm has a clear pathway to operate.

STEP 3: Place pivot mount brackets on trailer in orientation shown below. Using brackets as a guide, mark mounting hole locations.

FRONT OF TRAILER

RIVETS/CORRUGATION ON CENTER

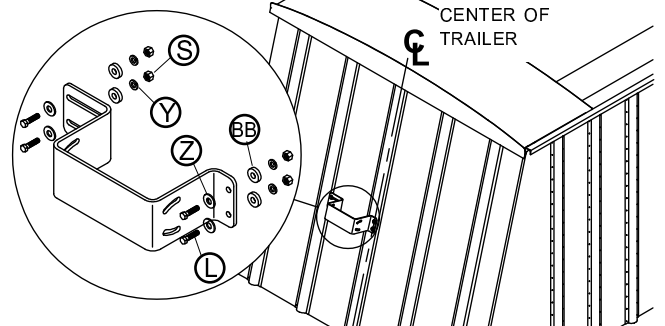

RIVETS/CORRUGATION OFF CENTER

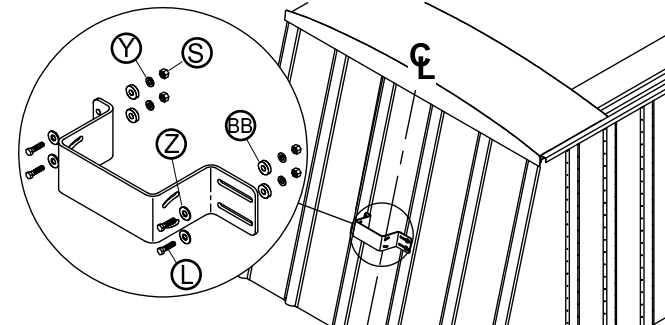

REAR OF TRAILER

RIVETS CORRUGATION ON CENTER

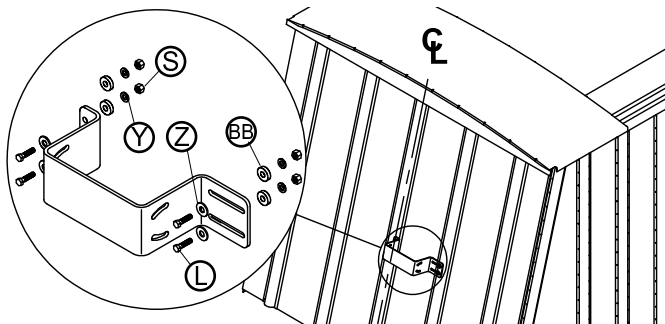

RIVETS/CORRUGATION OFF CENTER

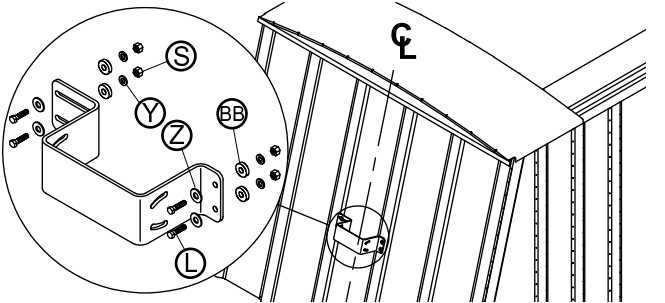

STEP 4: Drill 13/32" holes in trailer. Fasten sloped pivot mount bracket to trailer with 3/8" x 1 1/4" cap screws, flat washers, lock washers and nuts.

STEP 5: Place pivot brackets on pivot mount brackets in orientation shown below. Fasten pivot brackets to pivot mount brackets with 3/8" x 1 1/4" cap screws, flat washers, lock washers and nuts.

FRONT OF TRAILER

RIVETS/CORRUGATION ON CENTER

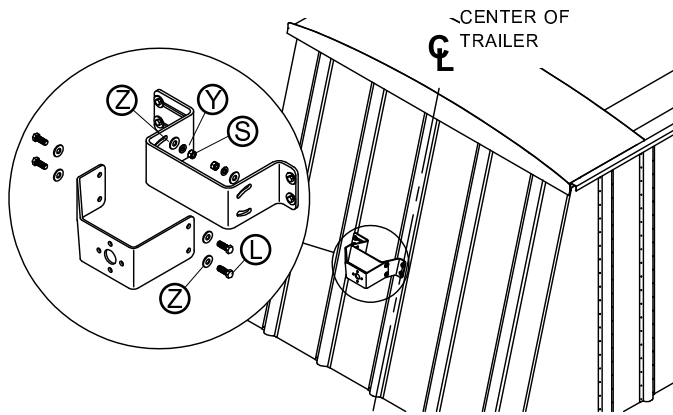

REAR OF TRAILER

RIVETS/CORRUGATION ON CENTER

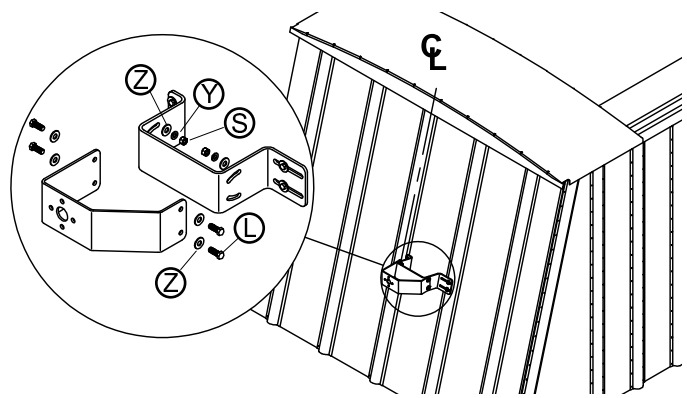

RIVETS/CORRUGATION OFF CENTER

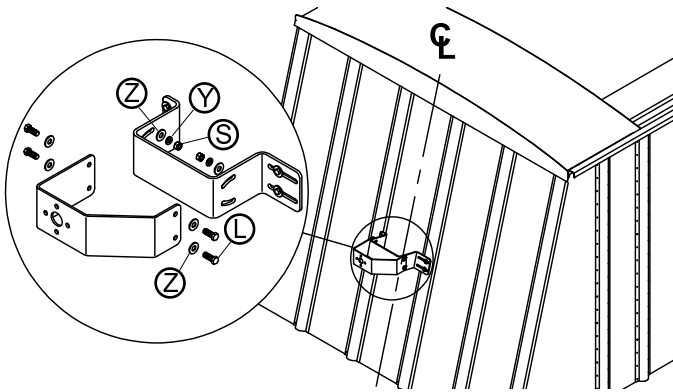

RIVETS/CORRUGATION OFF CENTER

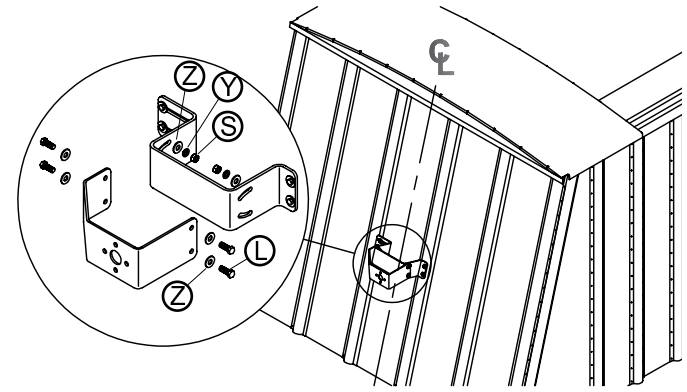

NOTE: Use pivot bracket washers **BB** only when horizontal corrugation on trailer skin prevents bracket from contacting trailer skin (see instructions on page 2).

NOTE: Read entire page before drilling holes.

Determine if ribs are centered or off center on front and rear of trailer.

FRONT OF TRAILER

STEP 1: Locate front pivot mount bracket on passenger's side of trailer so that center of pivot lies within shaded area shown below. Measure 42" down from top of cap or 44" from top of windshield.

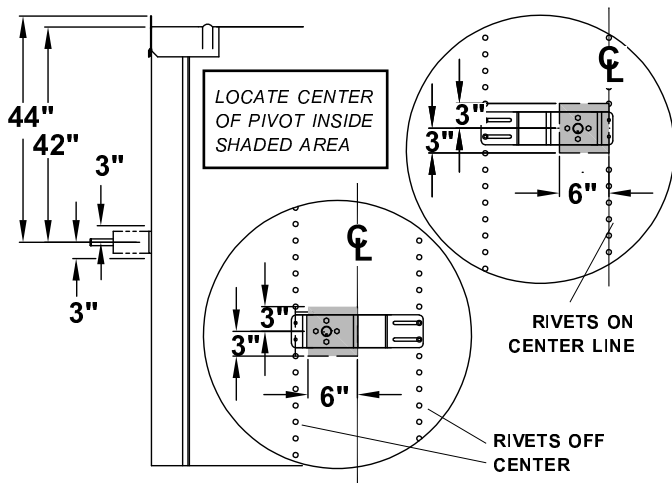

REAR OF TRAILER

STEP 2: Locate rear pivot mount bracket so that center of pivot lies within shaded area shown below.

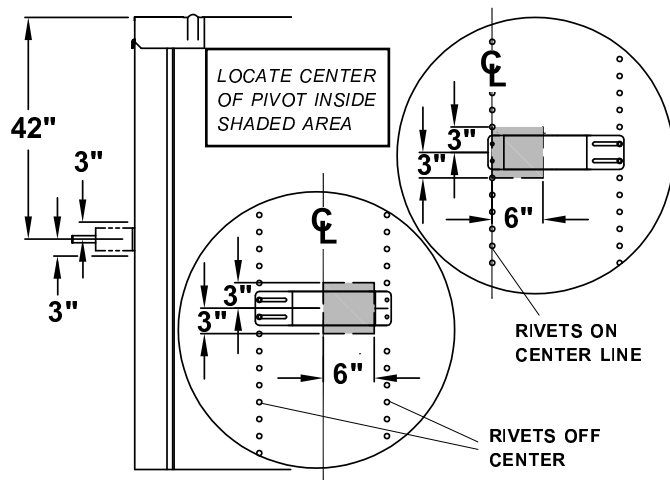

NOTE: Mount brackets into support braces on trailer if possible. If bracket cannot be mounted into support braces, reinforce mounting area with backer plate for adequate support. Before drilling any holes make sure flex arm has a clear pathway to operate.

STEP 3: Place pivot mount brackets on trailer in orientation shown below. Using brackets as a guide, mark mounting hole locations.

FRONT OF TRAILER

RIVETS/CORRUGATION ON CENTER

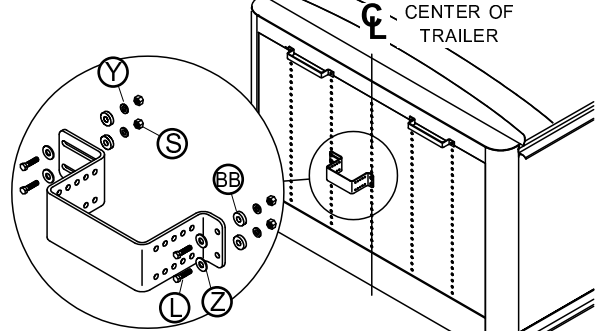

RIVETS/CORRUGATION OFF CENTER

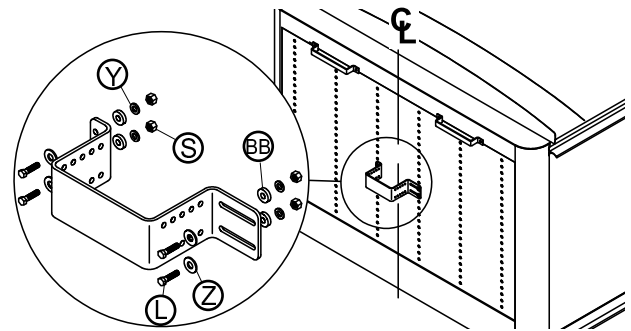

REAR OF TRAILER

RIVETS/CORRUGATION ON CENTER

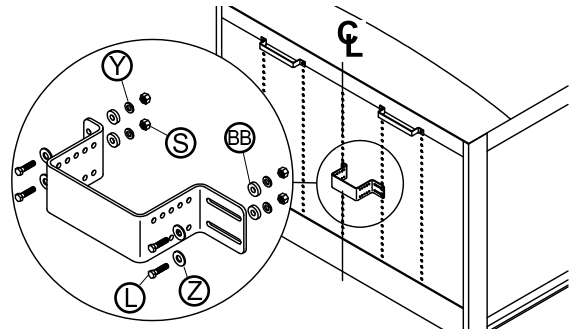

RIVETS/CORRUGATION OFF CENTER

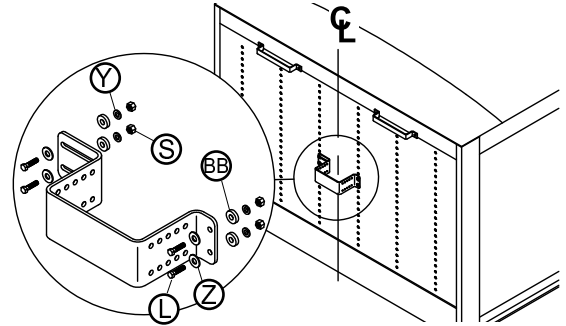

STEP 4: Remove rivets and mount brackets into rivet holes. If this is not possible, drill 13/32" holes in trailer. Fasten with 3/8" x 1 1/4" cap screws, flat washers, lock washers and nuts.

STEP 5: Place pivot brackets on pivot mount brackets in orientation shown below. Fasten pivot brackets to pivot mount brackets with 3/8" x 1 1/4" cap screws, flat washers, lock washers and nuts.

FRONT OF TRAILER

RIVETS/CORRUGATION ON CENTER

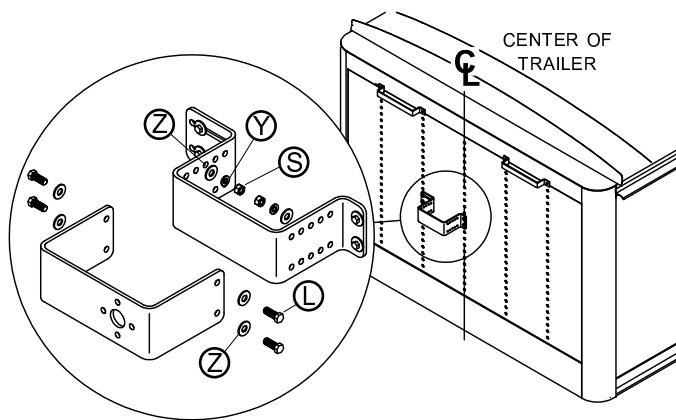

REAR OF TRAILER

RIVETS/CORRUGATION ON CENTER

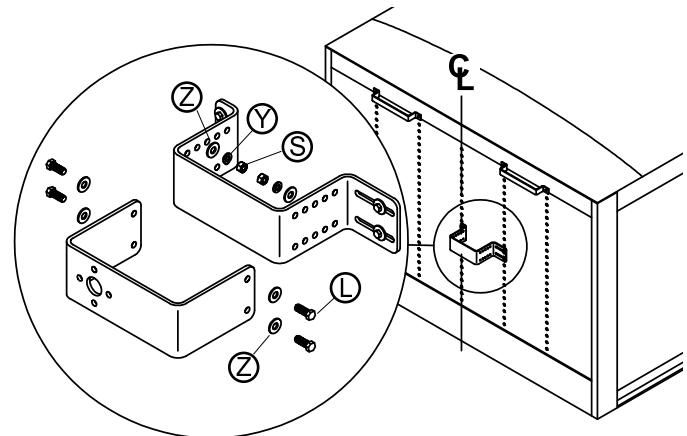

RIVETS/CORRUGATION OFF CENTER

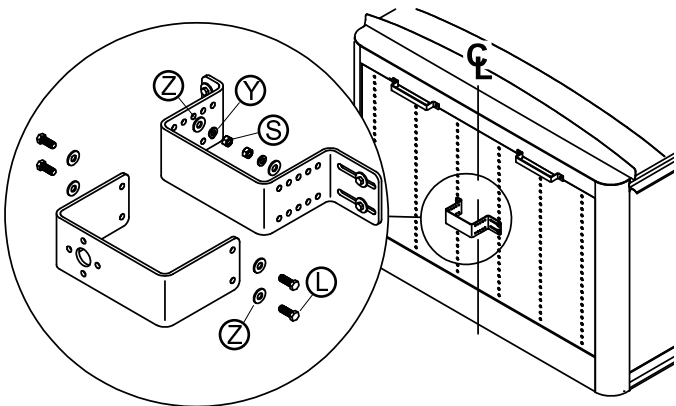

RIVETS/CORRUGATION OFF CENTER

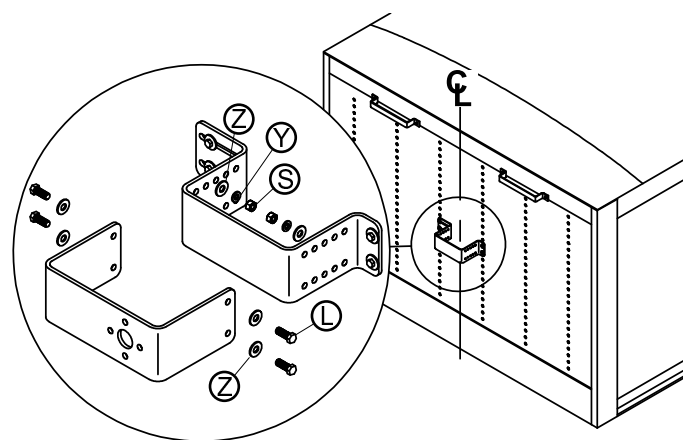

NOTE: Install pivot pin 1116920 before fastening pivot bracket to pivot mount bracket. See page 9.

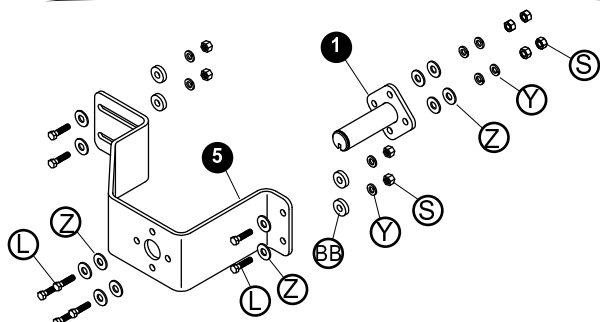

Item	Part #	Description
1.	1116920	Pivot Pin - 4 Spring
2.	1120361	Pivot Backer Plate - 5" x 16"
	1120418	Pivot Backer Plate - 5" x 20"
3.	1116922	Sloped Pivot Mount Bracket - 6" Standoff
	1117580	Sloped Pivot Mount Bracket - 8" Standoff
4.	1116923	Pivot Bracket - Sloped
5.	1116919	Vertical Pivot Mount Bracket - 7 1/4" Standoff
	1117031	Vertical Pivot Mount Bracket - 9 1/4" Standoff
K.	1700400	Self-Tapping Screw - 3/8" x 1"
L.	1702891	Cap Screw - 3/8" x 1 1/4"
S.	1700407	Hex Nut - 3/8"
Y.	1700434	Lock Washer - 3/8"
Z.	1700429	Flat Washer - 3/8"
BB.	1120291	Pivot Bracket Washer

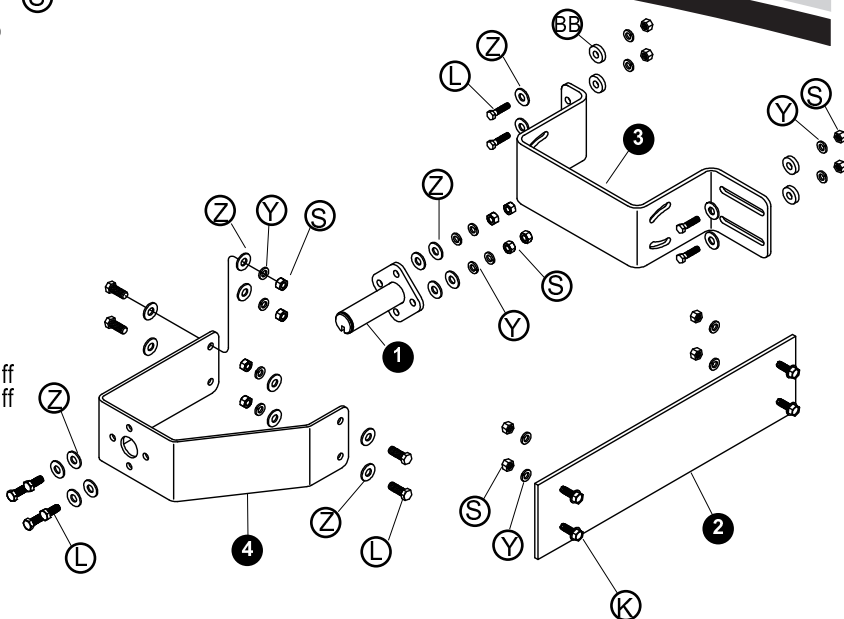

STEP 1: Align and loosely fasten pivot bracket to pivot mount bracket with 3/8" cap screws, lock washers and nuts.

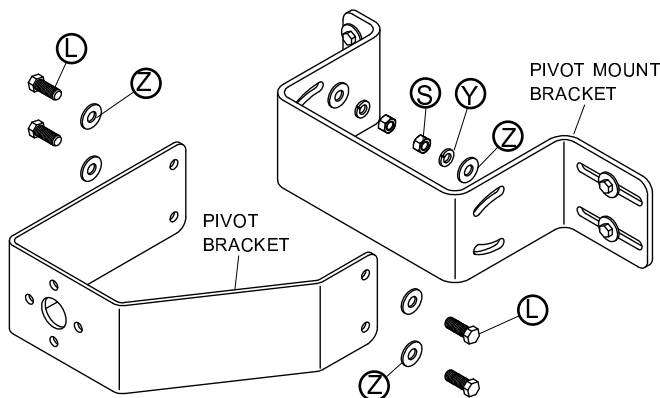

STEP 2: Align face of pivot bracket vertically and align pivot pin parallel with top rail of trailer, then tighten screws.

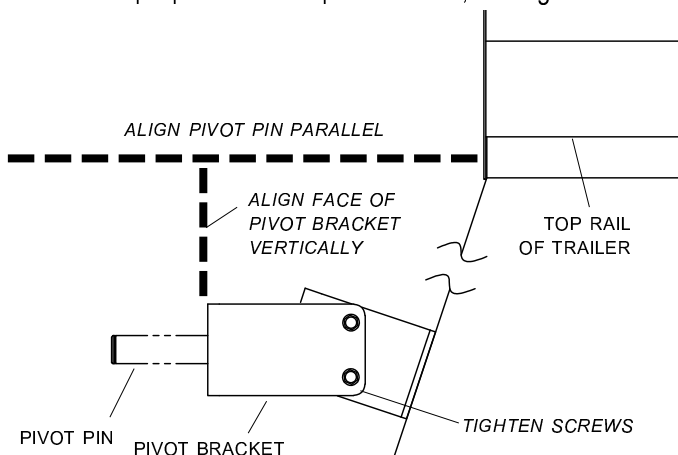

STEP 3: Fasten pivot pins to pivot brackets.

SLOPED TRAILER

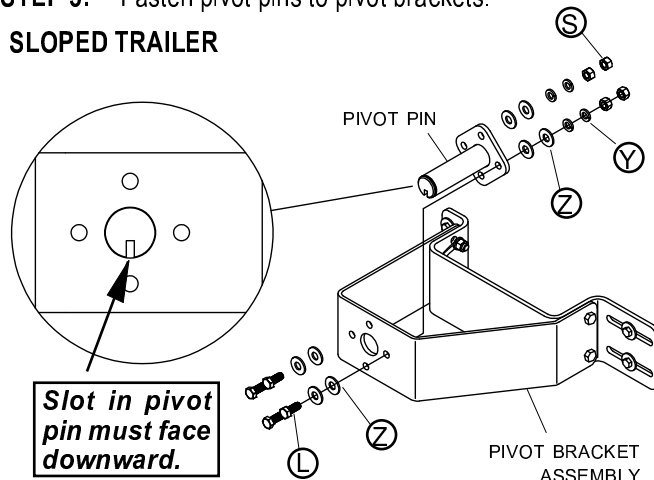

VERTICAL TRAILER

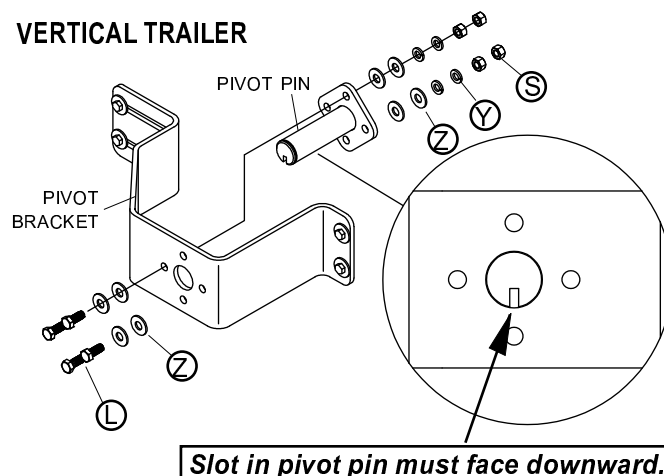

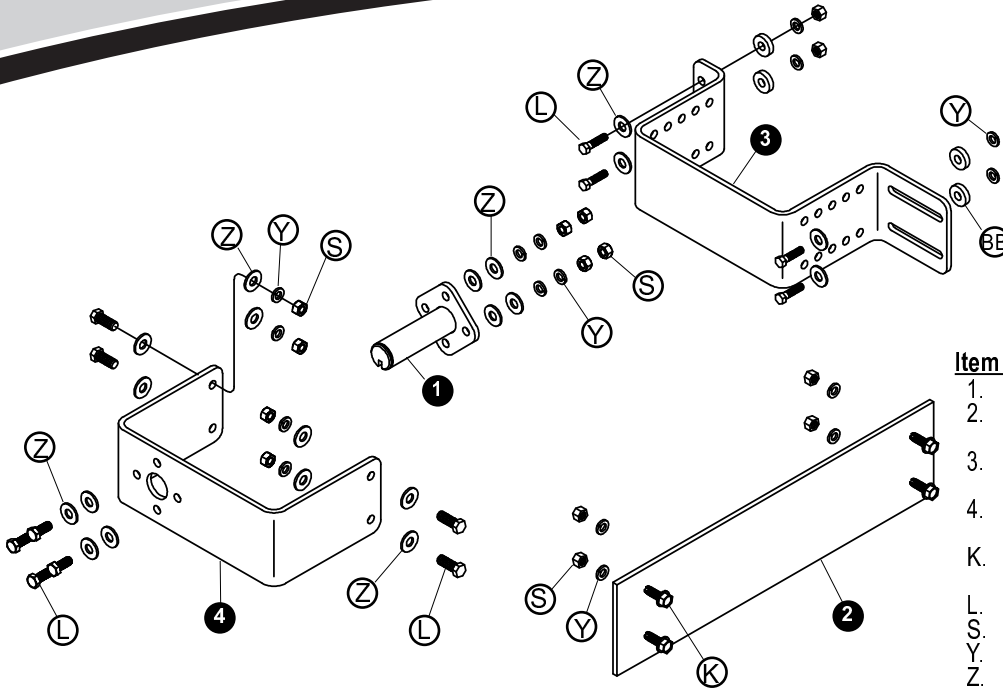

Item	Part #	Description
1.	1116920	Pivot Pin - 4 Spring
2.	1120361	Pivot Backer Plate - 5" x 16"
	1120418	Pivot Backer Plate - 5" x 20"
3.	1118860	Universal Pivot Mount Bracket
4.	1118861	Universal Pivot Bracket - Vertical
K.	1700400	Self-Tapping Screw - 3/8" x 1"
L.	1702891	Cap Screw - 3/8" x 1 1/4"
S.	1700407	Hex Nut - 3/8"
Y.	1700434	Lock Washer - 3/8"
Z.	1700429	Flat Washer - 3/8"
BB.	1120291	Pivot Bracket Spacer

STEP 1: Fasten pivot pins to pivot brackets.

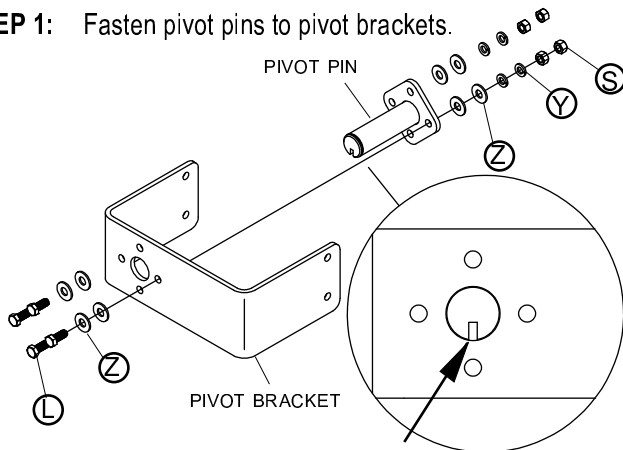

Slot in pivot pin must face downward.

STEP 2: Determine which holes in pivot mount bracket are as close as possible to the trailer but, if used, will not cause lower flex arm to interfere with the ladder or walkway. Use these holes to fasten pivot bracket to pivot mount bracket.

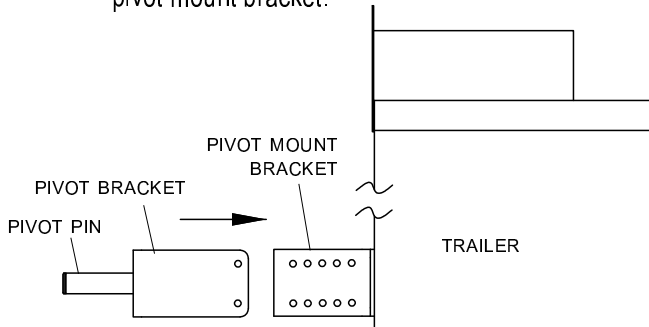

STEP 3: Align holes and loosely fasten pivot bracket to pivot mount bracket with 3/8" cap screws, flat washers, lock washers and nuts. Place lower pivot arm on pivot pin and check for lower flex arm clearance. Re-adjust pivot bracket position, if needed and tighten screws when lower flex arm is able to swing freely.

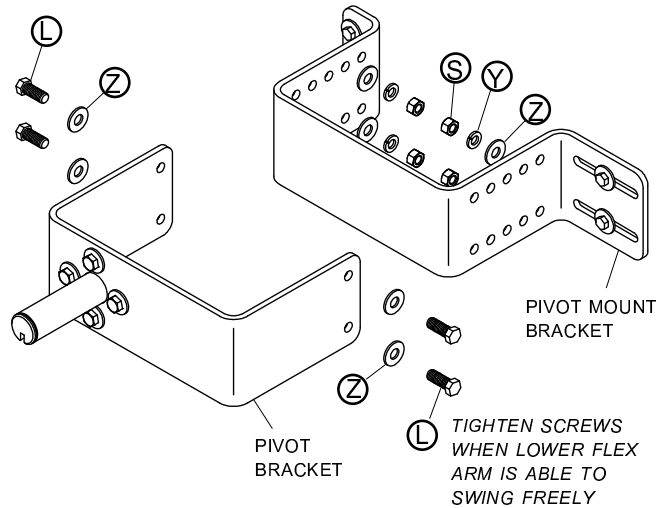

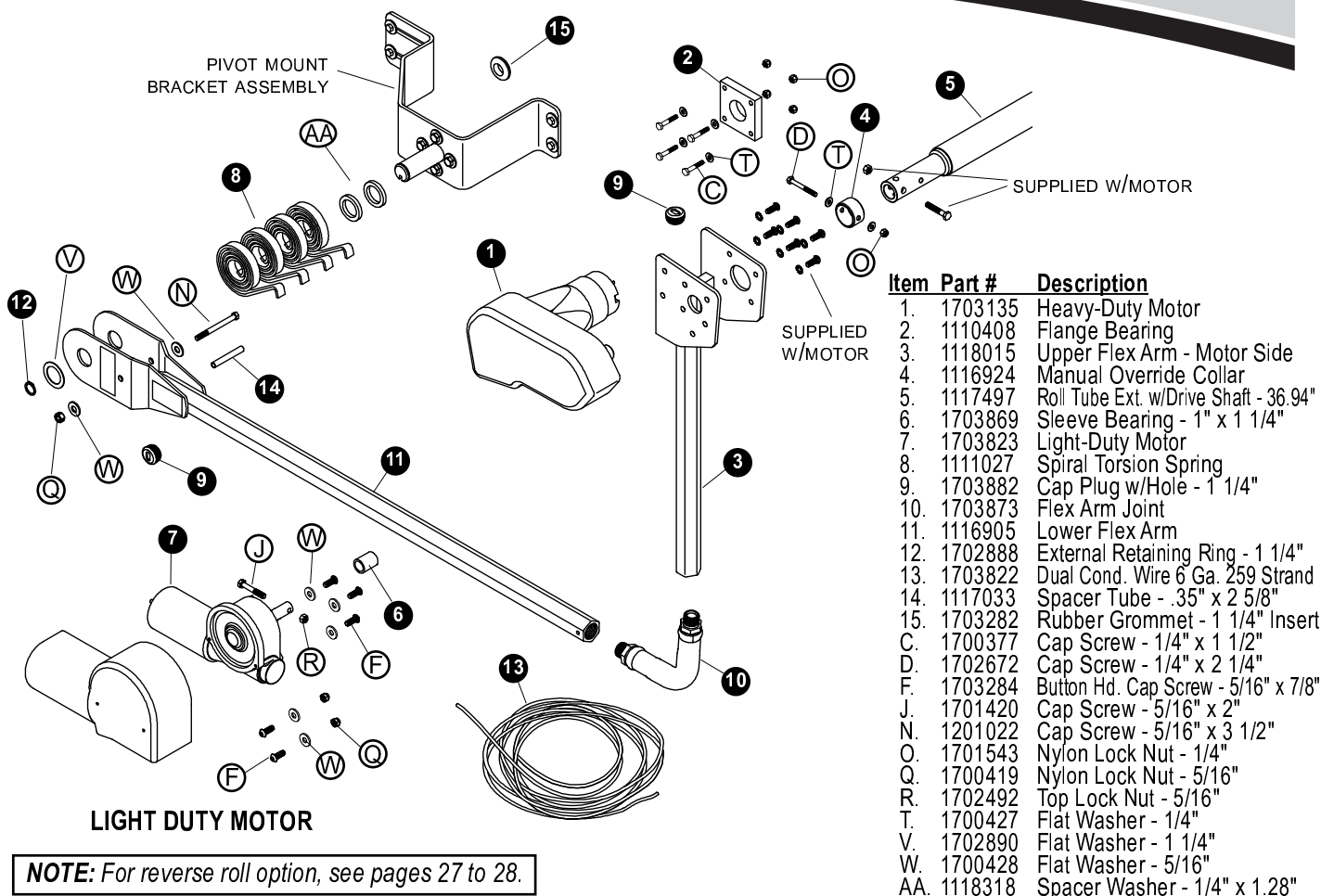

NOTE: For reverse roll option, see pages 27 to 28.

STEP 1: Install cap plug with hole on lower flex arm. Fasten spacer tube into spring support bracket on lower flex arm with 5/16" x 3 1/2" cap screw, two flat washers and nylon lock nut.

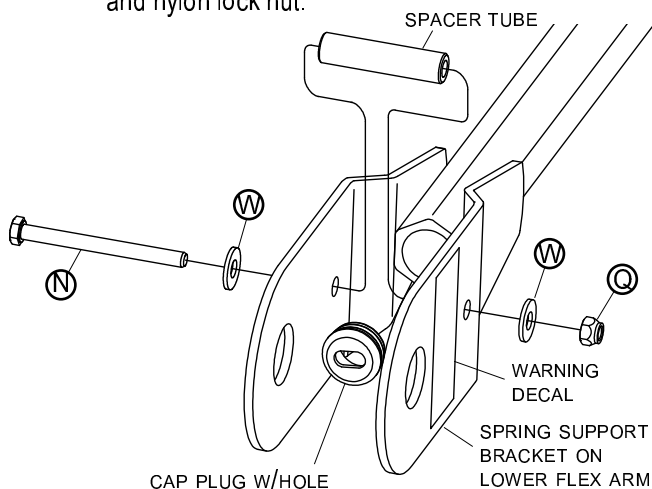

NOTE: Insert cap screw through flex arm so that head of screw will be on the inside of the assembly (toward the trailer). Warning label must be in plain view on outside of assembly.

STEP 2: Assemble spacer washers onto pivot pin.

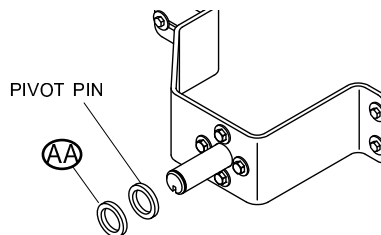

STEP 3: Assemble spiral torsion springs and lower flex arm onto pivot pin. Hook springs over 3/8" x 3 1/2" cap screw and spacer tube.

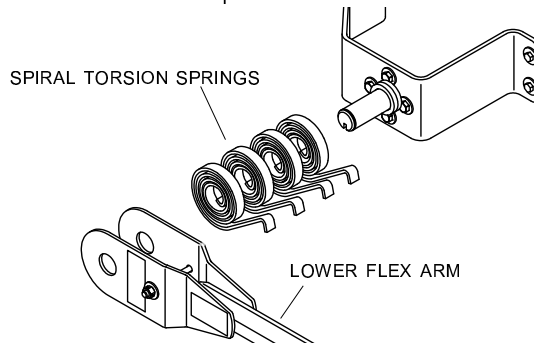

STEP 4: Secure with 1 1/4" flat washer and retaining ring.

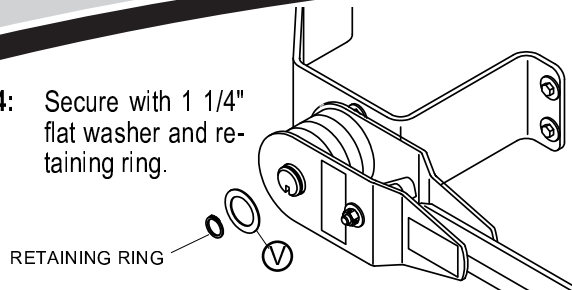

STEP 5: Insert wire (black with red stripe) through lower flex arm and flex arm joint. Thread flex arm joint into lower flex arm. Hand tighten only.

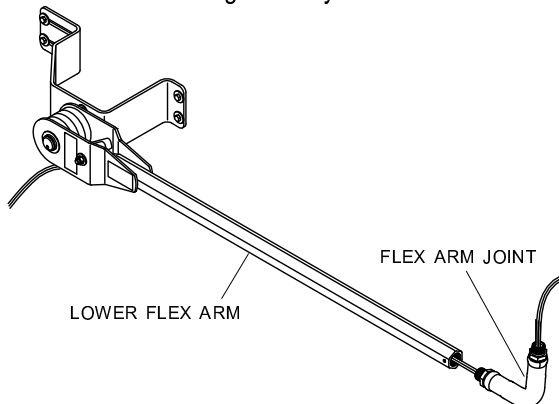

STEP 6: Insert wire through upper flex arm, then thread upper flex arm onto flex arm joint. Hand tighten only.

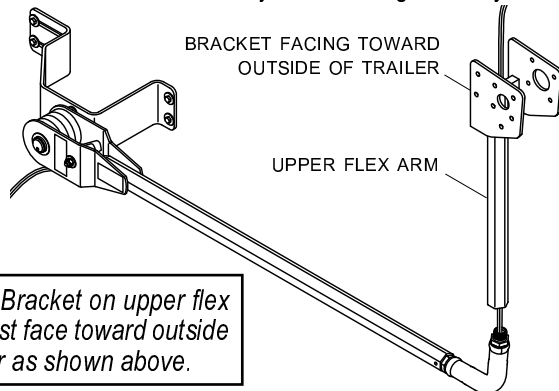

NOTE: Bracket on upper flex arm must face toward outside of trailer as shown above.

STEP 7: Drill 1 1/8" hole below pivot mount bracket. Press rubber grommet into hole and insert wire through grommet, leaving enough slack in wire to allow arm to travel.

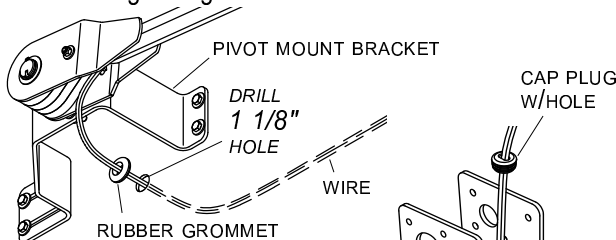

STEP 8: Install cap plug with hole on upper flex arm. Leave about 12" of wire extending out of flex arm.

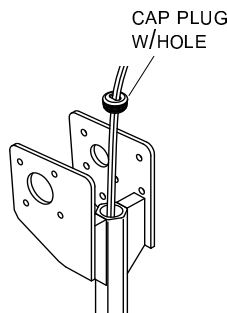

STEP 9: Mount electric motor to upper flex arm. Heavy-duty motor - use 5/16" button head cap screws and star washers supplied with motor. Light-duty motor - use 5/16" button head cap screws and flat washers.

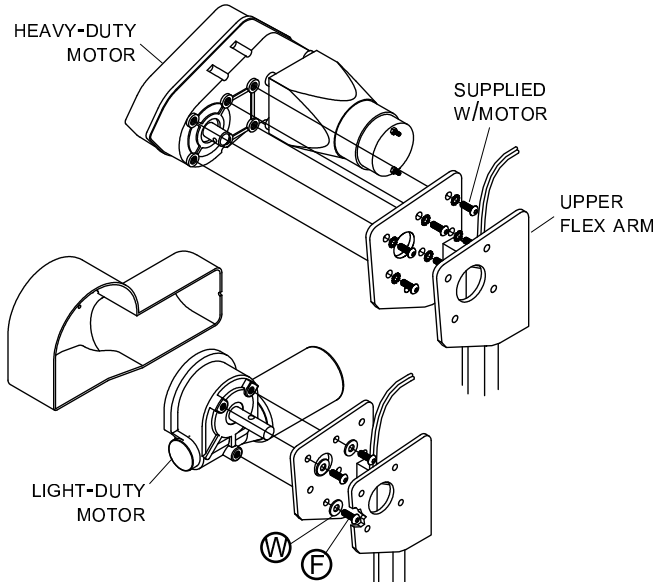

ATTENTION - FOR HEAVY-DUTY MOTOR:

- Use all mounting bolts when mounting gear motor.
- Do not use power tools.
- Do not overtighten (torque 5/16" x 7/8" Button Hd. Bolts to 70 in/lbs).
- Over tightening may crack case.
- Install star washers on the bolt side of the mounting plate.
- Do not use any form of thread locker.

STEP 10: Mount bearing flange to upper flex arm bracket with 1/4" x 1 1/2" cap screws, washers and nuts. **Finger tighten only to allow for adjustment.**

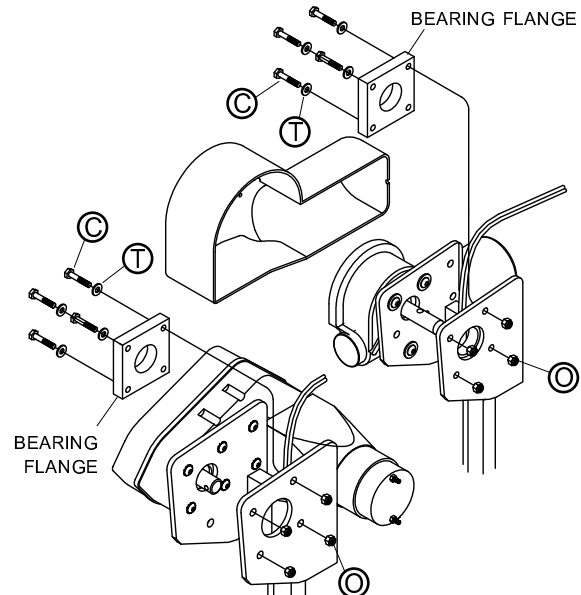

Item	Part #	Description
1.	1118309	Flange Bearing - 2"
2.	1703881	Cap Plug - 1 1/4" x 14-16 Ga.
3.	1117442	Upper Flex Arm - Bearing Side
4.	1704352	Rear Arm Retaining Collar
5.	1700789	Protective Cap
6.	1111027	Spiral Torsion Spring
7.	1702888	Retaining Ring - 1 1/4"
8.	1116905	Lower Flex Arm
9.	1703873	Flex Arm Joint
10.	1117033	Spacer Tube - .35" x 2 5/8"
A.	1704353	Self-Drilling Screw - 1/4" x 1"
H.	1703487	Cap Screw - 5/16" x 1 1/2"
N.	1201022	Cap Screw - 5/16" x 3 1/2"
Q.	1700419	Nylon Lock Nut - 5/16"
T.	1700427	Flat Washer - 1/4"
V.	1702890	Flat Washer - 1 1/4"
W.	1700428	Flat Washer - 5/16"
AA.	1118318	Spacer Washer - 1/4" x 1.28"

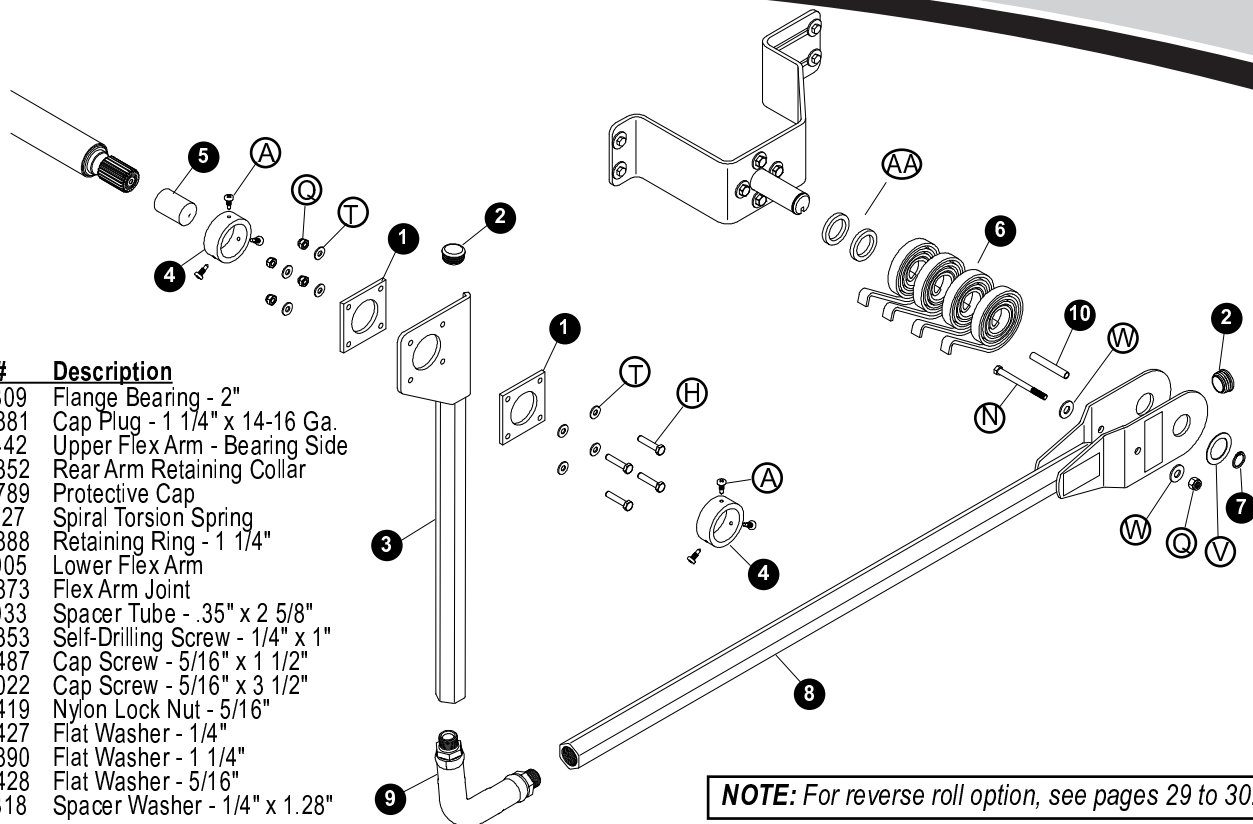

NOTE: For reverse roll option, see pages 29 to 30.

STEP 1: Install cap plug on lower flex arm. Fasten spacer tube into spring support bracket on lower flex arm with 5/16" x 3 1/2" cap screw, two flat washers and nylon lock nut.

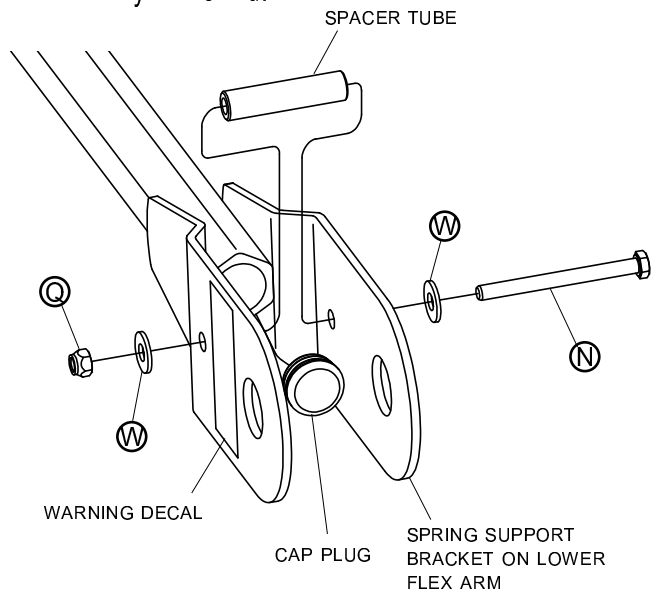

NOTE: Insert cap screw through flex arm so that head of screw will be on inside of assembly (toward the trailer). Warning label must be in plain view on outside of assembly.

STEP 2: Assemble spacer washers onto pivot pin.

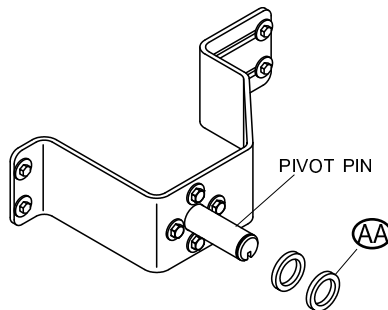

STEP 3: Assemble spiral torsion springs and lower flex arm onto pivot pin. Hook springs over 3/8" x 3 1/2" cap screw.

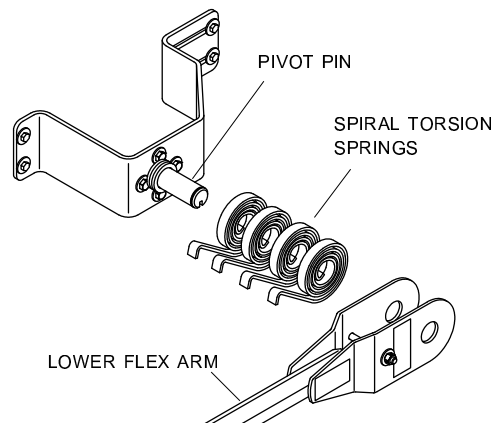

STEP 4: Secure with 1 1/4" flat washer and retaining ring.

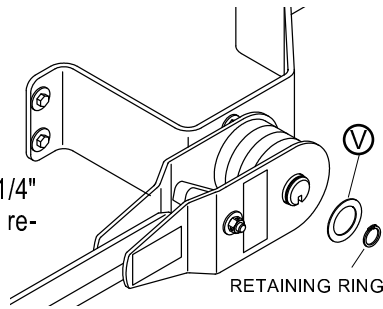

RETAINING RING

STEP 5: Install cap plug on rear upper flex arm.

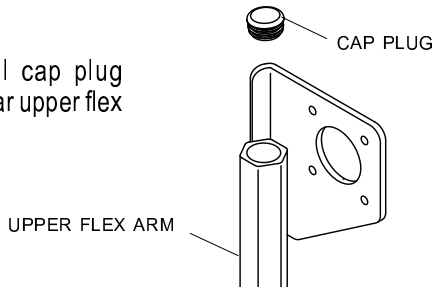

UPPER FLEX ARM

STEP 6: Thread flex arm joint into lower flex arm, then into upper flex arm. Hand tighten only.

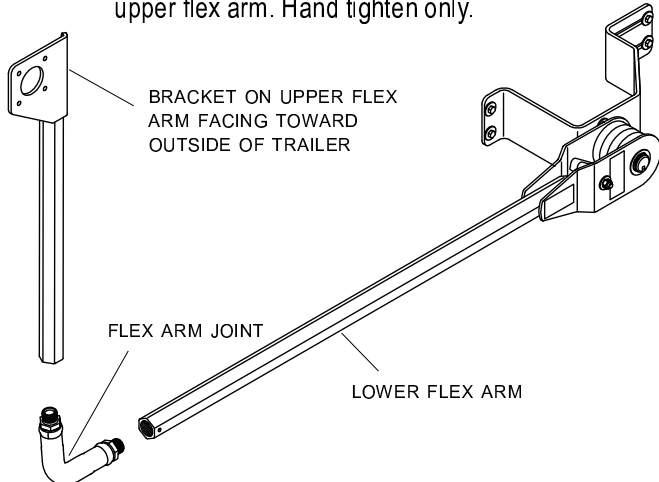

BRACKET ON UPPER FLEX ARM FACING TOWARD OUTSIDE OF TRAILER

FLEX ARM JOINT

LOWER FLEX ARM

NOTE: Bracket on upper flex arm must face toward outside of trailer as shown above.

STEP 7: Fasten bearing flanges to upper flex arm with 5/16" x 1 1/2" cap screws, flat washers and lock nuts as shown. **Finger tighten only to allow for adjustment.**

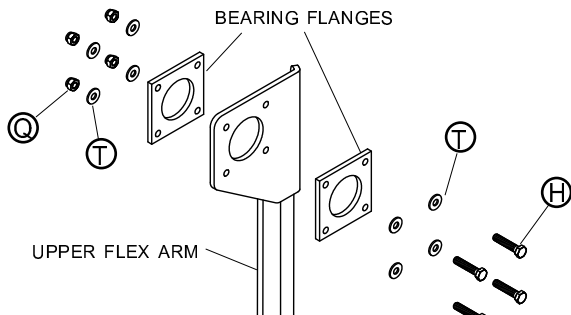

BEARING FLANGES

UPPER FLEX ARM

CAUTION

Do not open or close tarp without U-joint securely fastened to splined shaft with wire lock pin. Failure to do so could result in injury.

STEP 8: Roll tarp closed over box with roll tube hanging below latchplate. Remove crank assembly and U-clamps from roll tube.

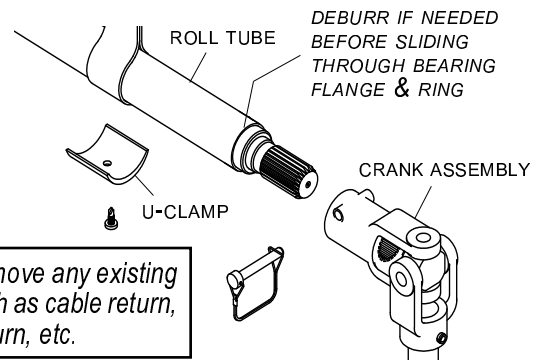

DEBURR IF NEEDED BEFORE SLIDING THROUGH BEARING FLANGE & RING

ROLL TUBE

U-CLAMP

CRANK ASSEMBLY

NOTE: Remove any existing returns such as cable return, bungee return, etc.

STEP 9: Slide first retaining collar over roll tube. Slide roll tube and spline through upper flex arm assembly, extending end of splined shaft 5" past flex arm bearing plate.

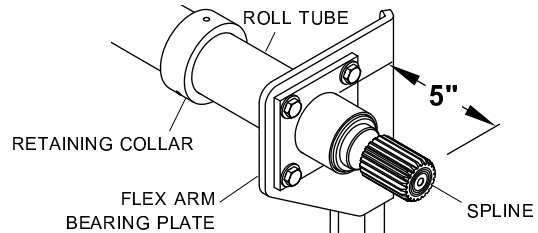

ROLL TUBE

RETAINING COLLAR

FLEX ARM BEARING PLATE

SPLINE

STEP 10: Slide second retaining collar onto roll tube. Align second retaining collar flush against flex arm assembly. Secure retaining collar to roll tube at three locating detents, using three provided 1/4" x 1" self-drilling screws.

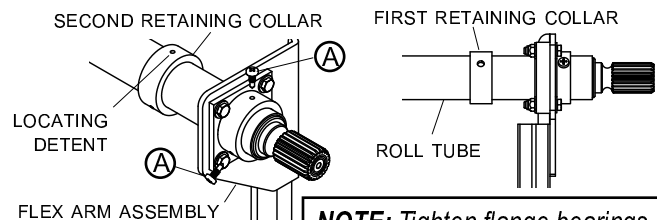

SECOND RETAINING COLLAR

FIRST RETAINING COLLAR

LOCATING DETENT

FLEX ARM ASSEMBLY

ROLL TUBE

NOTE: Tighten flange bearings.

NOTE: Do not leave unattended until flex arm is securely fastened to roll tube extension as shown.

WARNING

Flex arms are under tension while torsion springs are engaged. Use caution while assembling and disassembling arms. Failure to read and follow instructions could result in serious injury or death.

STEP 1: Rear of trailer: Adjust roll tube toward front or rear of trailer so that rear flex arm lies on a vertical plane that is parallel to face panel and perpendicular to the roll tube extension. Mark roll tube where roll tube extension ends.

VERTICAL TRAILER

ALIGN FLEX ARM WITH VERTICAL PLANE PARALLEL TO FACE PANEL

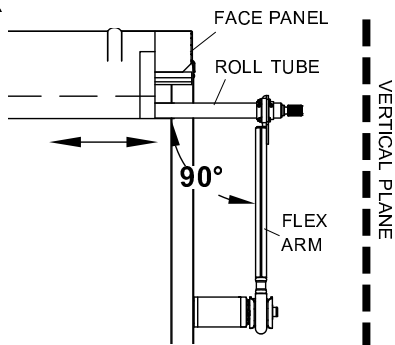

SLOPED TRAILER

ALIGN FLEX ARM WITH VERTICAL PLANE PARALLEL TO FACE PANEL

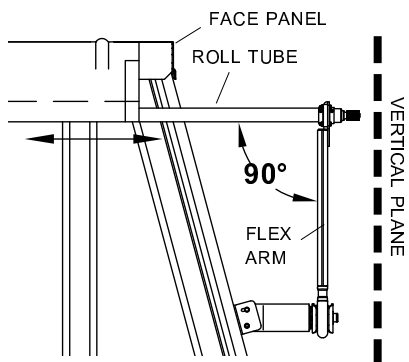

STEP 2: Front of trailer: Slide tarp back on roll tube.

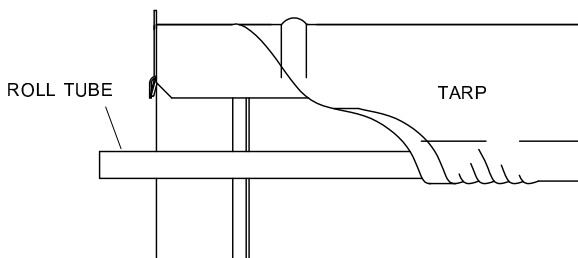

VERTICAL TRAILER

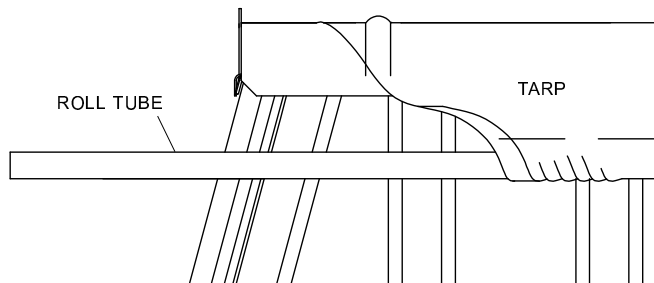

SLOPED TRAILER

STEP 3: Fasten motor to roll tube extension:

LIGHT-DUTY MOTOR

Tap sleeve bearing into end of roll tube extension. Drill two 11/32" holes into sleeve bearing through 11/32" holes in roll tube extension.

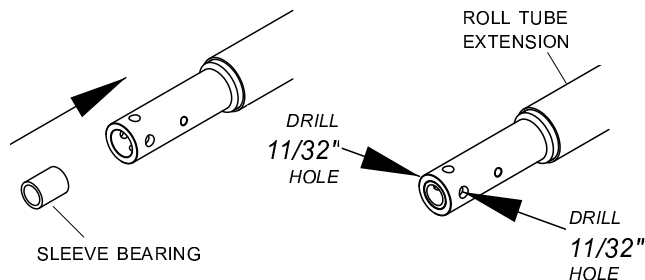

Insert motor shaft into roll tube extension. Fasten motor shaft to roll tube extension with 5/16" x 2" cap screw and top lock nut. Finger tighten only.

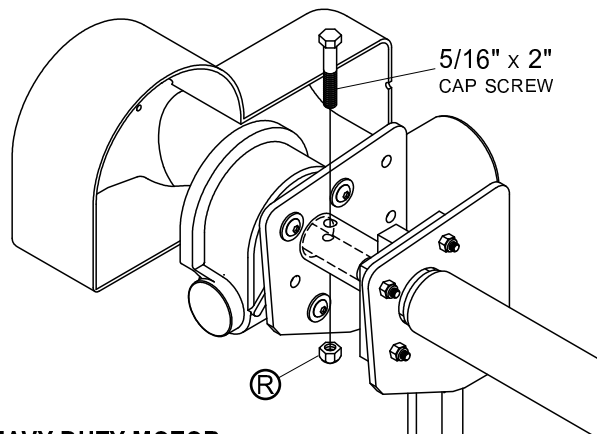

HEAVY-DUTY MOTOR

Insert motor shaft into roll tube extension with drive shaft. Fasten motor shaft to roll tube extension with bolt and nut supplied with motor. Finger tighten only.

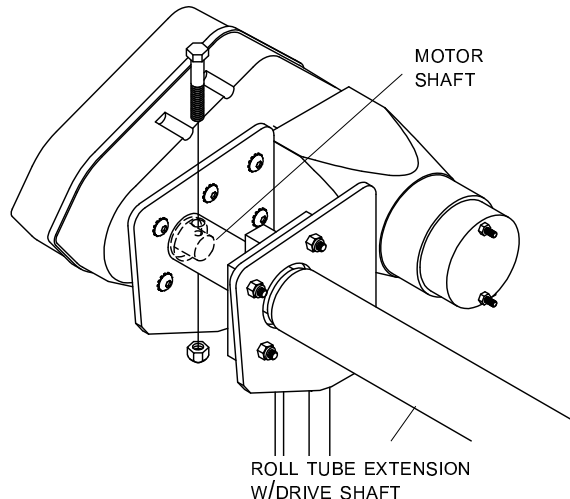

STEP 4: Hold flex arm with motor and roll tube extension in vertical plane to trailer and 90° to roll tube. Mark roll tube at location to be cut.

NOTE: Requires two people for safe installation.



CAUTION

On certain trailers, clearance lights might be in the way of the roll tube and can be damaged if caution is not taken. In some instances, a 'deflector' might have to be installed to prevent the roll tube from causing damage to these lights.

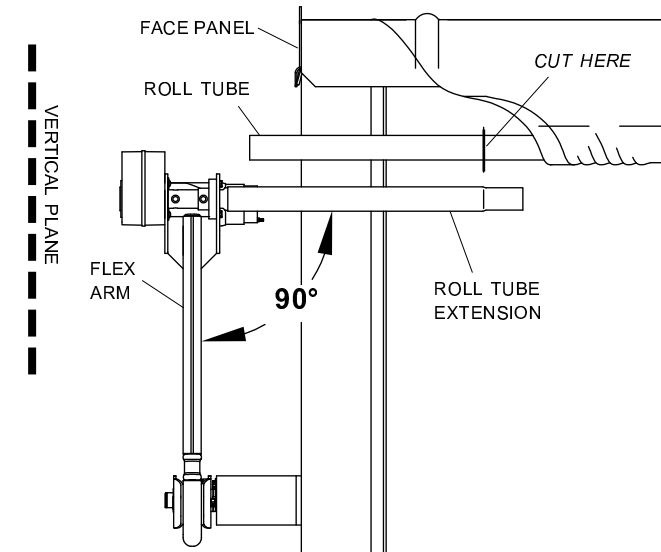

VERTICAL TRAILER

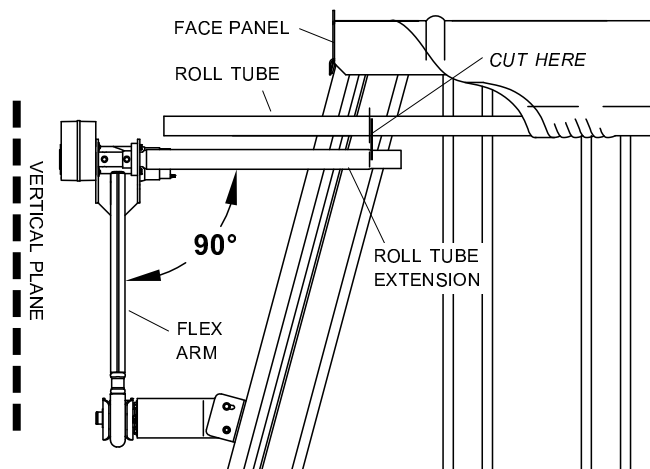

SLOPED TRAILER

STEP 5: Unfasten and remove motor from roll tube extension. Remove roll tube extension from roll tube. Cut roll tube at marked location.

STEP 6: Insert swaged end of roll tube extension w/drive shaft into roll tube. Align extension straight with roll tube and weld all around. Grind smooth.

NOTE: Pull roll tube away from tarp and trailer before welding to protect from weld spatter. Align roll tube extension straight with roll tube before welding so tarping system will roll smoothly.

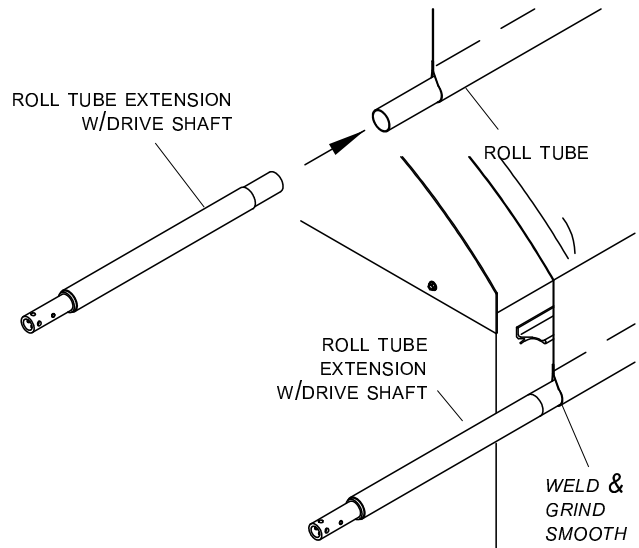

NOTE: To prevent rust, paint all exposed metal such as weld seams and/or metal exposed by grinding or cutting, with corrosion-resistant paint.

STEP 7: Slide roll tube/roll tube extension weldment back into position and align upper flex arm on front of trailer. Follow steps 8 to 10 to install motor, positioning motor as shown below. Make sure torsion springs load when tarp opens.

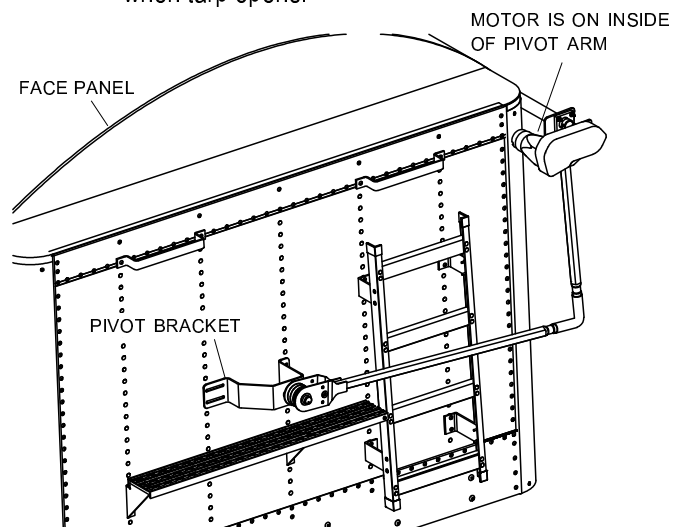

STEP 8: Hang manual override collar over electric motor shaft.

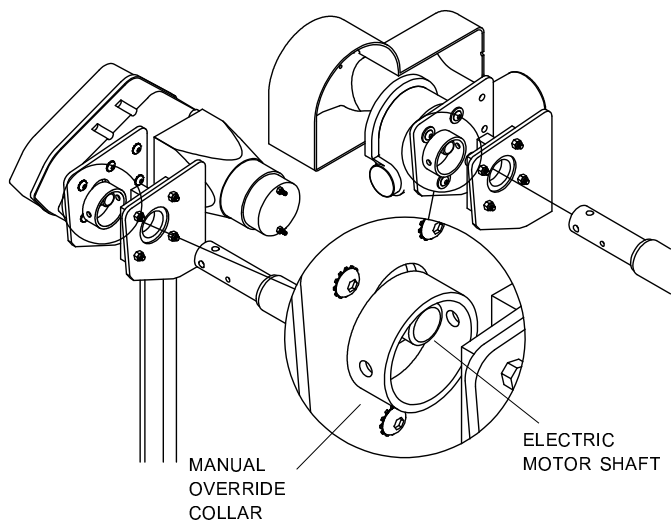

WARNING
 Flex arms are under tension while torsion springs are engaged. Use caution while assembling and disassembling arms. Failure to read and follow instructions could result in serious injury or death.

STEP 9: Insert roll tube extension through upper flex arm bracket and manual override collar. Secure roll tube to electric motor shaft with 3/8" x 2 1/4" cap screw and top lock nut (supplied with motor). Light-duty motor - secure with 5/16" x 2" cap screw and top lock nut.

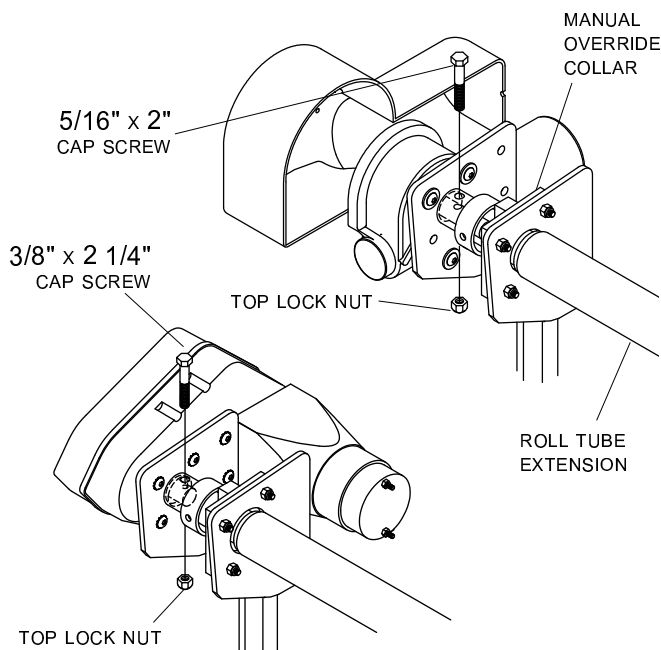

STEP 10: Fasten manual override collar to roll tube with 1/4" x 2 1/4" cap screw, two flat washers and lock nut.

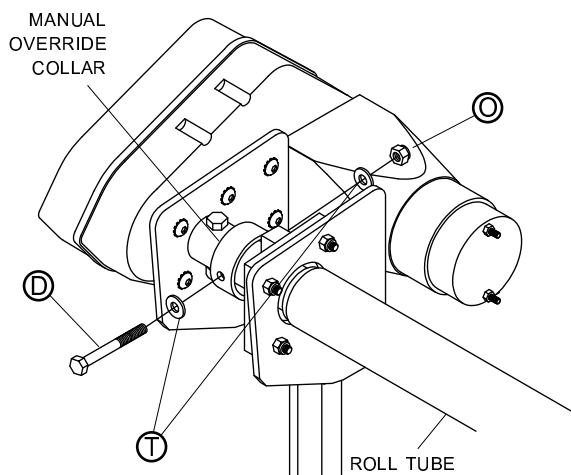

NOTE: Verify again that flex arm is on a vertical plane and is parallel to the face panel before proceeding. Make sure all fasteners holding motor to upper flex arm bracket are tightened securely.

STEP 11: Adjust rear roll tube extension to align flex arm on a vertical plane that is parallel to face panel. Do not drill holes and/or fasten until tarp and roll tube are in desired position.

STEP 12: When both front and rear flex arms are vertical, slide first retaining collar flush with bearing plate. Fasten collar to roll tube at three locating detents, using three provided 1/4" x 1" self-drilling screws.

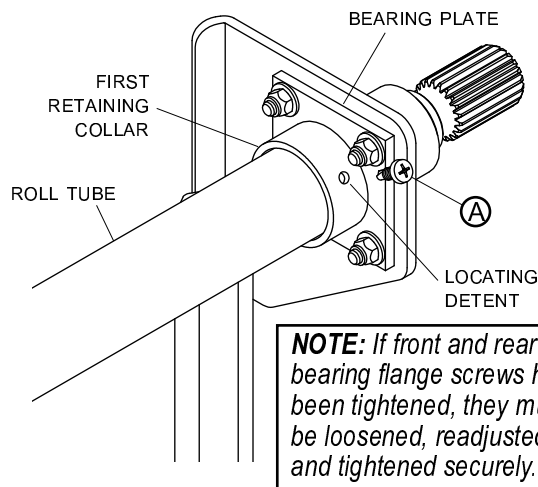

STEP 13: Re-fasten tarp to roll tube with existing U-clamps and screws. Tighten all fasteners securely. Tighten front and rear flex arm connections.

Item	Part #	Description
1.	1703661	Rocker Switch Mounting Bracket
2.	1116020	Rocker Switch
3.	1703845	Motor Reversing Solenoid
4.	1109015	Mounting Bracket - Conductor Socket
5.	1115385	Heavy-Duty Dual Conductor Plug
6.	1115386	Heavy-Duty Dual Conductor Socket
7.	1704354	40-Amp Modified Reset Circuit Breaker
8.	1704573	Conductor Socket Sealed Boot
9.	1703896	Solenoid Cover
10.	1703245	Ring Terminal - 6 Ga. x #10 Stud
11.	1703244	Ring Terminal - 6 Ga. x 3/8"
12.	1704153	Ring Terminal - 14 Ga. x 1/4" Stud
13.	1703659	Push On Terminal - 14 Ga. x 1/4"
14.	1702707	Ring Terminal - 6 Ga. 1/4 Stud
B.	1700381	Cap Screw - 1/4" x 1"
E.	1701045	Cap Screw - 5/16" x 3/4"
K.	1700400	Self-Tapping Screw - 3/8" x 1"
O.	1701543	Nylon Lock Nut - 1/4"
P.	1700411	Hex Nut - 5/16"
S.	1700407	Hex Nut - 3/8"
Y.	1700434	Lock Washer - 3/8"

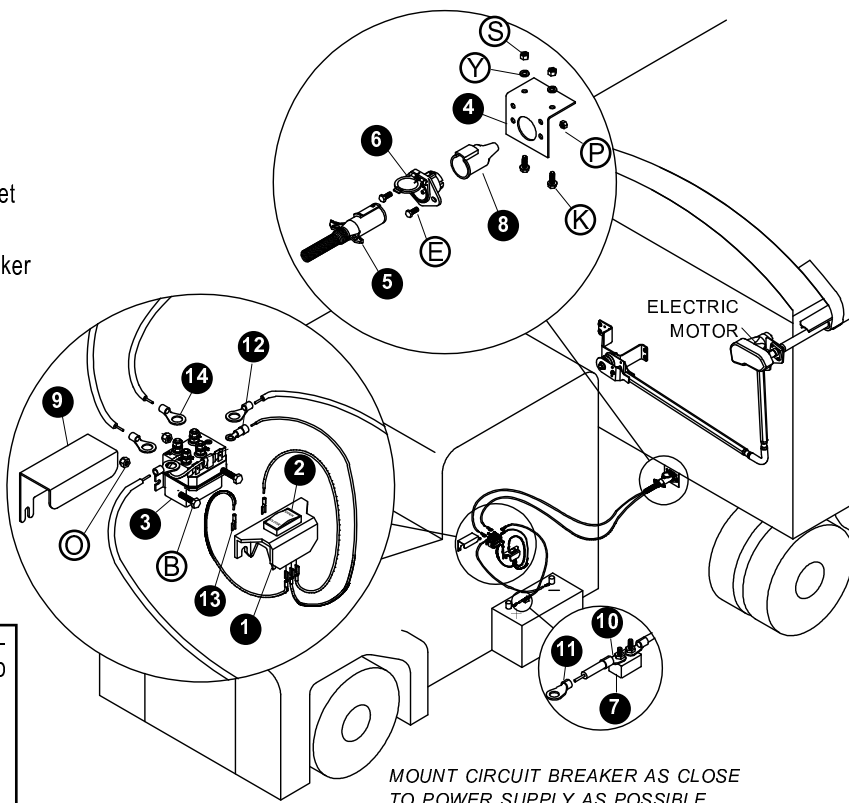

Cut wires to length and strip only enough wire insulation to install ring terminals. Insert bare wire into ring terminals and crimp securely.

STRIP WIRE INSULATION
RING TERMINAL
CRIMP SECURELY

STEP 1: Circuit breaker & battery. Mount circuit breaker as close as possible to battery or power supply.

STEP 2: Mount solenoid. Mount solenoid in a suitable location - a ventilated area near the battery is ideal. Determine best route for wire. This is usually along the frame with existing wire harness. Run 6-ga. wire from conductor plug to solenoid and from power supply to solenoid as shown in diagram. Run 14-ga. wires from solenoid to switch.

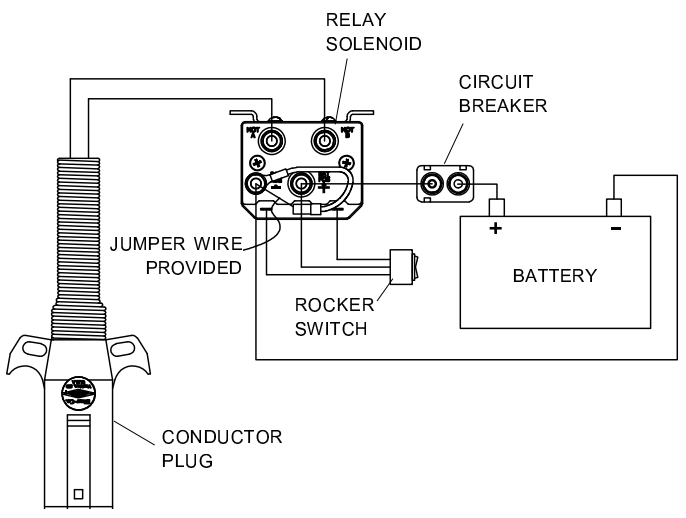

STEP 3: Rocker switch. Locate rocker switch in a convenient operating location. Switch can be mounted in cab, on dash panel, on driver side door jamb or in a convenient location outside the cab.

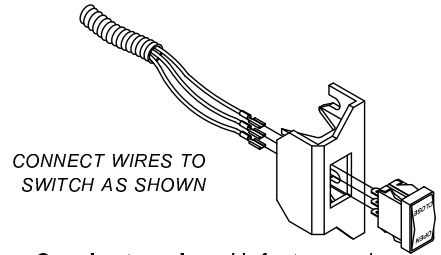

STEP 4: Conductor plug. Unfasten and remove insert from conductor plug. Feed 6-ga. wire through plug and into brass contacts on insert. Tighten set screws to secure wires. Replace insert into conductor plug and secure screw.

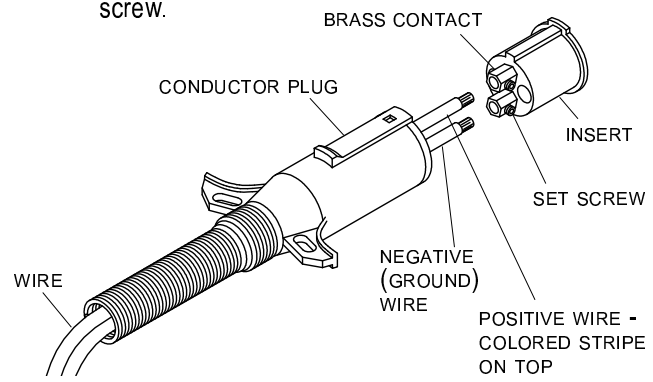

STEP 1: Mounting bracket.

Mount bracket at suitable location on front of trailer, usually near existing plugs. Mark and drill 5/16" holes and fasten with 3/8" x 1" self-tapping screws, lock washers and nuts.

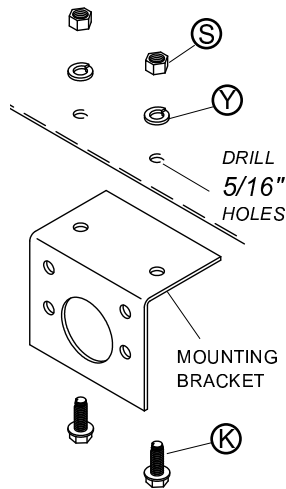

STEP 2: Conductor socket. Fasten conductor socket to mounting bracket with screws **E** and nuts **P**.

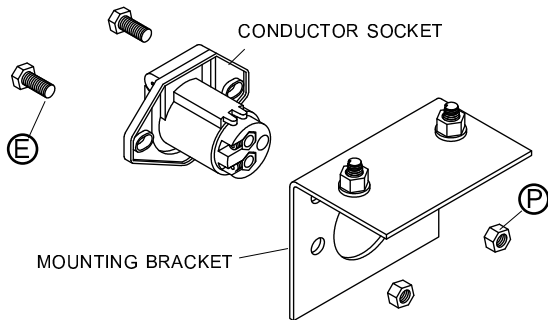

Bring 6 ga. wire from lower end of pivot arm through sealed boot. Connect wire ends to conductor socket, aligning positive wire on socket with positive wire on conductor plug. Slide sealed boot against conductor socket and secure boot to wire with cable tie.

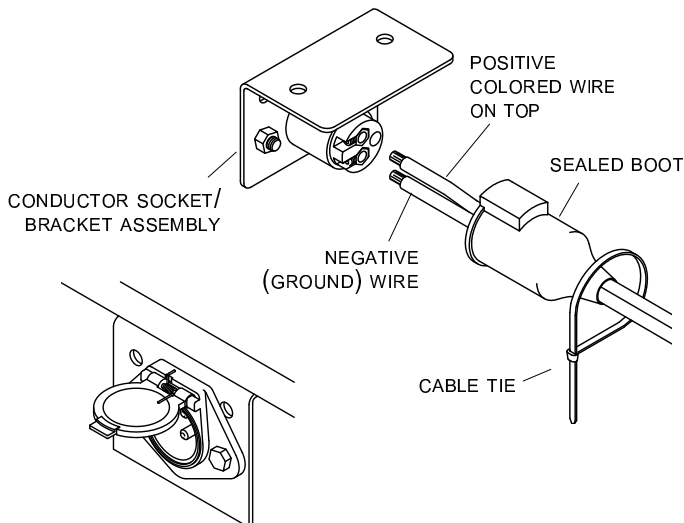

STEP 3. Connect wires at top of pivot arm to motor.

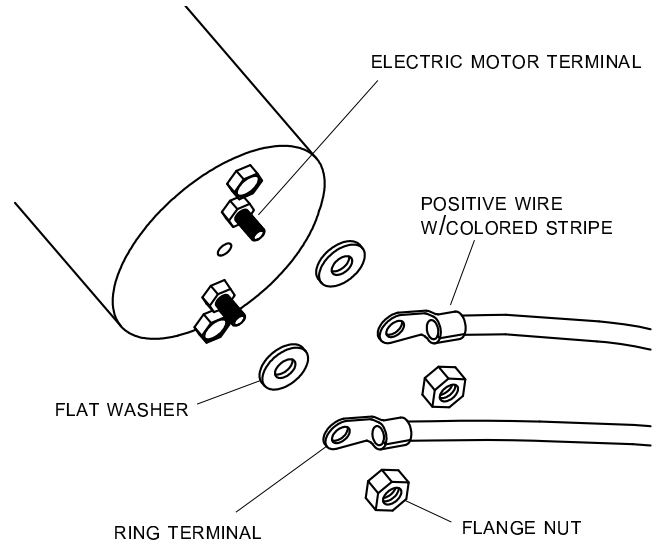

CAUTION
Check all hardware for complete assembly before operating. Inspect system at this time and adjust as required.

OPERATION:

- A)** Check motor direction by activating switch to "OPEN". If switch is running system backwards, change wire leads on motor to opposite connections.
- B) Close tarp:** Push switch to "CLOSE" and hold. Observe tarp and release switch when tarp is fully closed.
- C) Open tarp:** Push switch to "OPEN" and hold. Observe tarp and release switch when tarp is fully open.

NOTE: Release switch at end of cycle or modified-reset circuit breaker will trip. After breaker resets, switch will activate motor again. To reduce unnecessary strain on tarp components, release switch at end of each cycle.

Item	Part #	Description
1.	1118257	Shur-Co® Wireless Receiver
2.	1109015	Mounting Bracket
3.	1115385	Heavy-Duty Dual Conductor Plug
4.	1115386	Heavy-Duty Dual Conductor Socket
5.	1704354	40-Amp Modified-Reset Circuit Breaker
6.	1702707	Ring Terminal - 6 Ga. 1/4" Stud
7.	1704330	Rubber Insulating Boot
8.	1704573	Conductor Socket Sealed Boot
9.	1703282	Rubber Grommet - 1 1/4" Insert
10.	1702108	Wire Clip - 3/4"
11.	1704338	Self-Tapping Screw - 1/4" x 1"
12.	1703244	Ring Terminal - 6 Ga. x 3/8" Stud
E.	1701045	Cap Screw - 5/16" x 3/4"
G.	1702926	Cap Screw - 5/16" x 7/8"
K.	1700400	Self-Tapping Screw - 3/8" x 1"
P.	1700411	Hex Nut - 5/16"
Q.	1700419	Lock Nut - 5/16"
S.	1700407	Hex Nut - 3/8"
W.	1700428	Flat Washer - 5/16"
Y.	1700434	Lock Washer - 3/8"

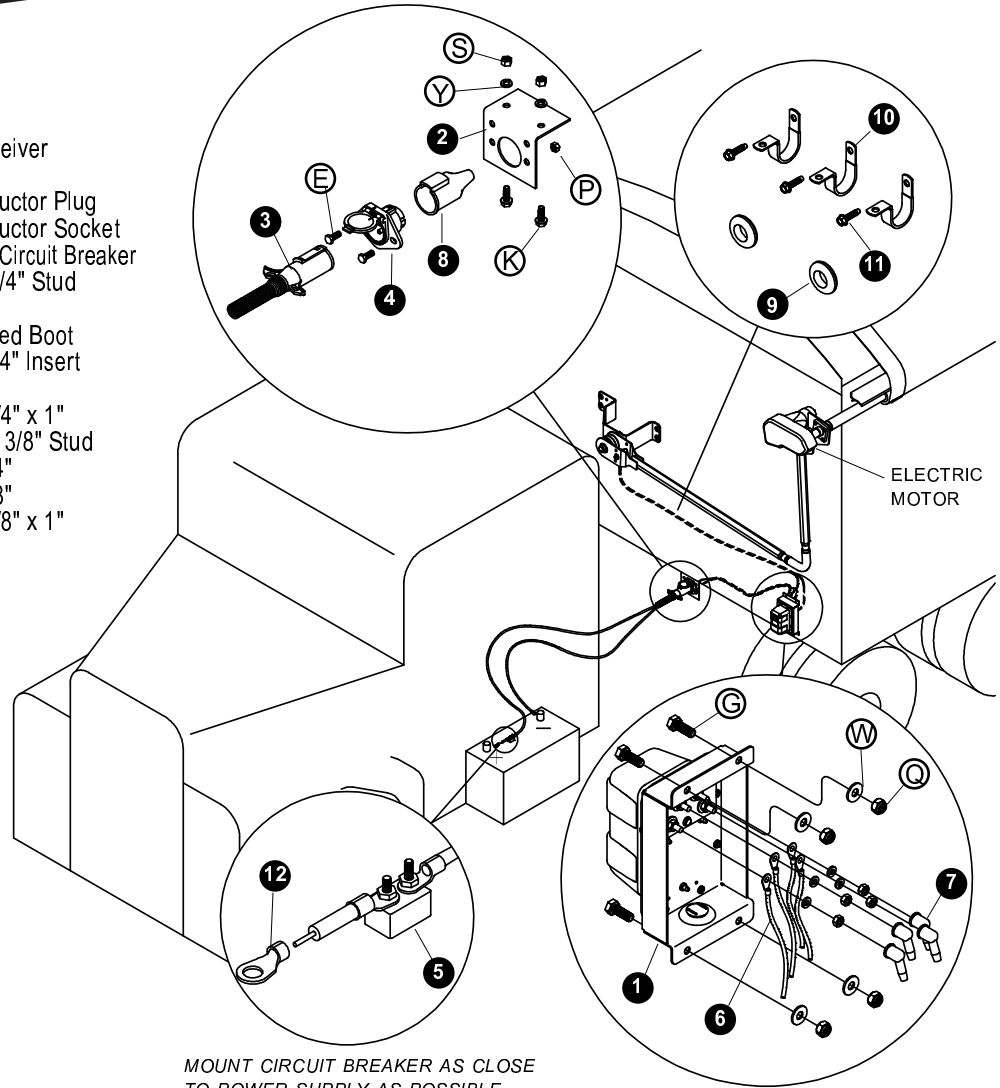

Cut wires to length and strip only enough wire insulation to install ring terminals. Insert bare wire into ring terminals and crimp securely.

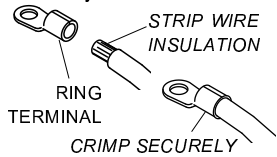

MOUNT CIRCUIT BREAKER AS CLOSE TO POWER SUPPLY AS POSSIBLE

STEP 1: Circuit breaker & battery: Mount circuit breaker as close as possible to battery or power supply.

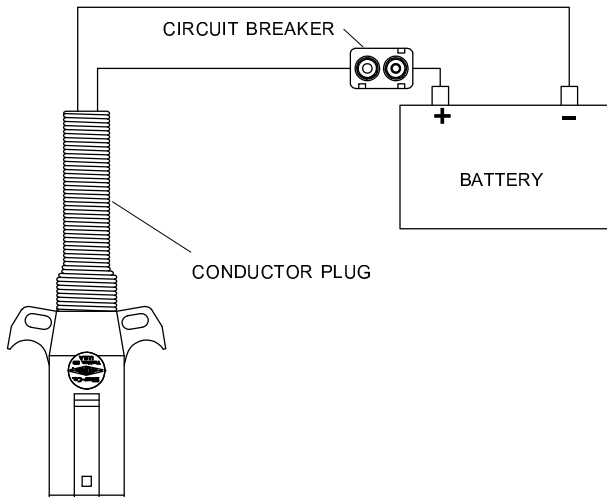

STEP 2: Conductor plug: Unfasten and remove insert from conductor plug. Feed 6 ga. wire through plug and into brass contacts on insert. Tighten set screws to secure wires. Replace insert into conductor plug and secure screw.

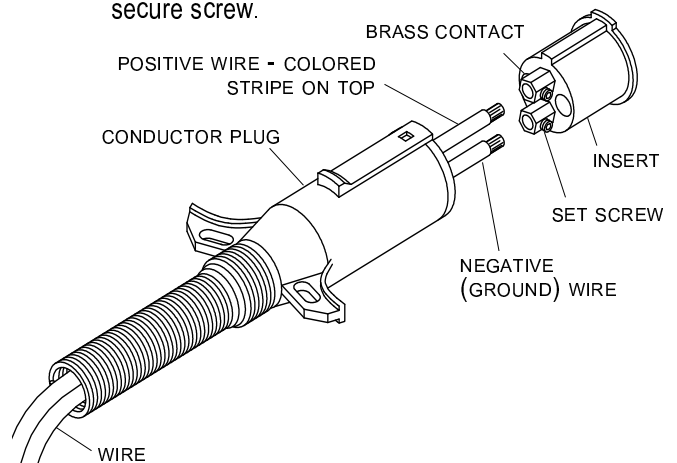

STEP 1: Mounting bracket.

Mount bracket at suitable location on front of trailer, usually near existing plugs. Mark and drill 5/16" holes and fasten with screws **K**, lock washers **Y** and nuts **S**.

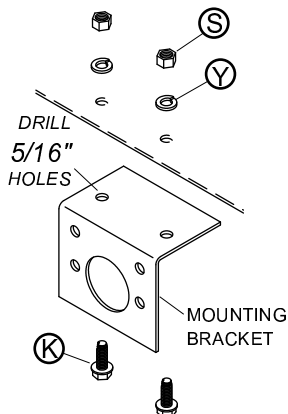

STEP 2: Conductor socket. Fasten conductor socket to mounting bracket with screws **B** and nuts **P**. Bring 6-ga. wire from lower end of pivot arm through sealed boot. Connect wire ends to conductor socket, aligning positive wire on socket with positive wire on conductor plug. Slide sealed boot against conductor socket and secure boot to wire with cable tie.

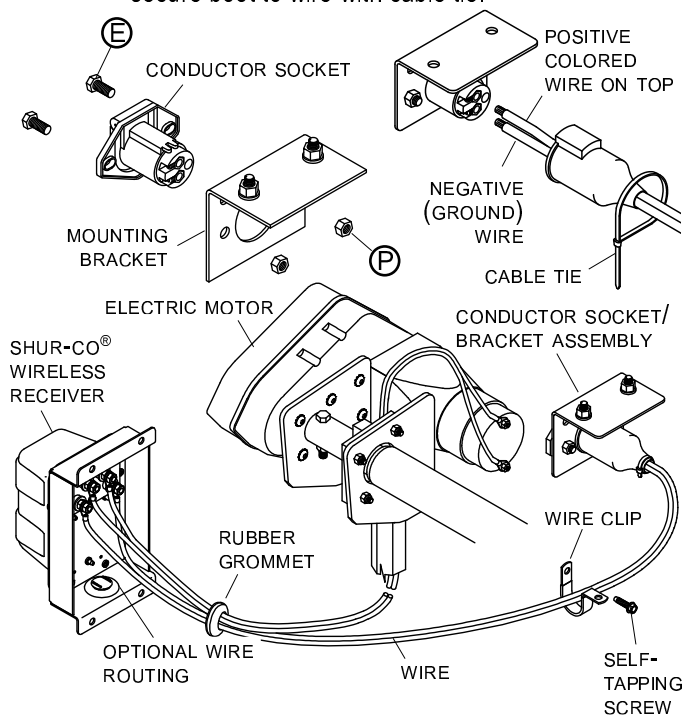

STEP 3: Shur-Co® wireless receiver. Identify 6-ga. wires running from electric motor through front pivot arm and grommets. Route wires as desired, securing with wire clips and self-tapping screws. Drill 1 1/8" hole through front of trailer at suitable location for wireless receiver. Insert grommet into hole and push wire through grommet. Insert ends of wires through rubber boots, then crimp 1/4" ring terminals onto wire ends. Remove nuts and lock washers from back of wireless receiver. Place positive wire on upper orange post and negative wire on upper black post. Secure lock washers and hex nuts. Coat with dielectric grease and install rubber boots over ring terminals.

USE DIELECTRIC GREASE (PART #1704378) TO PREVENT CORROSION ON TERMINALS.

Run section of 6 ga. wire, long enough to reach conductor socket, through rubber boots. Crimp 1/4" ring terminals to wire ends. On back of wireless receiver, place positive wire on lower orange post and negative wire on lower black post. Secure with 1/4" lock washers and hex nuts. Coat with dielectric grease and install rubber boots over ring terminals. When wiring socket, align positive wire with positive wire on conductor plug.

Mount wireless receiver to cover grommet. Mark and drill 11/32" holes and fasten with 5/16" x 7/8" cap screws, flat washers and lock nuts.

STEP 4: Connect wires at top of pivot arm to motor.

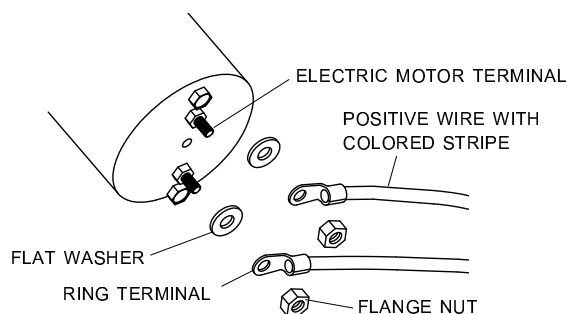

CAUTION
Check all hardware for complete assembly before operating. Inspect system at this time and adjust as required.

OPERATION:

A) Check motor direction by activating switch to "OPEN". If switch is running system backwards, change wire leads on motor to opposite connections.

B) Close tarp: Push switch to "CLOSE" and hold. Observe tarp and release switch when tarp is fully closed.

C) Open tarp: Push switch to "OPEN" and hold. Observe tarp and release switch when tarp is fully open.

NOTE: Release switch at end of cycle or modified-reset circuit breaker will trip. After breaker resets, switch will activate motor again. To reduce unnecessary strain on tarp components, release switch at end of each cycle.

NOTE: Pressure wash. Receiver may be pressure washed, but keep nozzle at least 3' from system while spraying.

Power-up/down:

The transmitter will power up when the lid is opened. The transmitter will power down when the lid is closed or when the lid is left open three minutes after the last button is pushed.

Standard operation:

After power-up, the first channel will be immediately active and the LED indicator for this channel will be flashing. The *Open/On* and *Close/Off* buttons are operational for the indicated active channel. While pressed, the LED indicator will flash faster, indicating channel operation.

The *Select* button will cycle between enabled channels. If only one channel is enabled, there will be no apparent change when the *Select* button is pressed.

Channel programming mode:

The Shur-Co® SMARTransmitter® has five channels. Pressing the *Select* button toggles through these channels. Unused channels can be disabled if desired, using the following process, but your transmitter is fully operational as shipped. This process may be skipped. Unused transmitter channels will not perform any functions.

Hold the *Select* button down for 10 seconds and the transmitter will enter *Channel Programming Mode*. Each time *Channel Programming Mode* is entered, the status of all five channels must be reset.

While In *Channel Programming Mode*, the programmable channel will be indicated by a solid lit LED.

NOTE: The transmitter will NOT activate any motor or lighting system while the transmitter is in *Channel Programming Mode*.

Press the *Open/On* button to enable the current channel (designated by the indicator light). Press the *Close/Off* button to disable the current channel. The indicator light will automatically jump to the next channel.

After programming all five channels, the transmitter will display the programmed channel status for all channels for three seconds. All enabled channel LEDs will be lit solid and all disabled channel LEDs will not be lit. Buttons will not function during this three second period.

The transmitter will automatically exit *Channel Programming Mode* after three seconds and return to *Operational Mode*.

NOTE: If there is not at least one enabled channel after programming, the transmitter will not save the changes and will revert back to the previously saved channel settings.

TIP: To cancel your changes and exit *Channel Programming Mode*, close the transmitter cover.

Channel programming example:

The transmitter in this example is labeled with the following five channels:

- Tarp System
- Front Hopper
- Back Hopper
- Lights
- Auxiliary

These channel labels are for a standard agricultural transmitter. Your transmitter label may differ.

The task is to enable the *Tarp System*, *Front Hopper* and *Back Hopper* channels.

1. Hold down the *Select* button for 10 seconds. The transmitter will enter *Learn Mode*. The *Tarp System* channel LED will be lit. All other channel LEDs are off.
2. Press the *Open/On* button to enable the *Tarp System* channel. The *Front Hopper* LED will now be lit.
3. Press the *Open/On* button to enable the *Front Hopper*. The *Back Hopper* LED will be lit.
4. Press the *Open/On* button to enable the *Back Hopper*. The *Lights* channel LED will be lit.
5. Press the *Close/Off* button to disable the lights. The *Auxiliary* LED will be lit.
6. Press the *Close/Off* button to disable the *Auxiliary* channel LED.
7. The transmitter will display all activated channels for three seconds. The transmitter will automatically exit *Channel Programming* and revert to *Operational Mode*. The *Tarp System* LED will be flashing, indicating that the channel is active and ready for operation.

SMARTransmitter® to receiver programming:

Shur-Co® SMARTrailer® wireless systems are typically pre-programmed at the factory or by the dealer and should be ready to use as shipped. Re-programming is necessary after replacement transmitters or receivers are installed.

Use the following method to program the RF receiver to accept and respond to signals from up to five transmitters. The receiver will not accept or respond to signals from transmitters that have not been programmed using this method.

1. Remove the receiver cover, pulling gently on the cover to prevent damage to wires that are connected to the rocker switch.
2. Check to be sure the 3500 is connected to the power supply. The receiver must be connected to power to be programmed. If a battery disconnect switch is installed, make sure it is turned on.
3. The receiver can learn to recognize and respond to up to five transmitters. Gather all of the transmitters to be introduced to the receiver. Open the transmitter lid(s) in order to turn them on.
4. Set the transmitter(s) to the appropriate channel (*Tarp System*, etc.). See *Transmitter Operation & Programming Instructions*.

NOTE: Read the following steps in their entirety before proceeding. Steps 6 to 8 must be completed within 10 seconds.

5. Press and hold the programming button on the bottom of the RF solenoid for five seconds. The solenoid will beep to indicate that it is in programming mode. Release the programming button.
6. Press the *Open/On* button on the first transmitter being introduced. The receiver will beep after receiving the transmitter signal.
7. Repeat step 6 for any remaining transmitters.
8. The receiver will expect five signals, so if you are programming less than five transmitters, press the *Open/On* button additional times on the last transmitter you are programming. Push the *Open/On* button a total of five times (see programming example).
9. After pushing the *Open/On* button five times, the receiver will beep twice to indicate that it has been programmed successfully.

NOTE: The receiver will exit program mode after 10 seconds, whether or not it has five *Open/On* button signals.

10. Verify each transmitter is operating correctly. If none of the transmitters are operating correctly, verify there are 12 to 14 volts from the receiver positive to negative, then repeat steps 3 to 9.

11. Refasten receiver cover.

Receiver programming example:

In this example, the receiver controls the 3500 motor. The task is to program the receiver to recognize three transmitters.

1. Remove the receiver cover and turn on the three transmitters.
2. Set all three transmitters to the tarp system channel.
3. Press and hold the programming button on the RF solenoid for five seconds. The solenoid will beep to indicate it has entered *Channel Programming Mode*. Release the programming button.
4. Press the *Open/On* button on the first transmitter. The receiver will beep to indicate that it has received a signal and memory slot #1 has been filled.
5. Press the *Open/On* button on the second transmitter. The receiver will beep to indicate that it has received a signal and memory slot #2 has been filled.
6. Press the *Open/On* button on the third transmitter. The receiver will beep to indicate that it has received a signal and memory slot #3 has been filled.
7. Press the *Open/On* button on the third transmitter again. The receiver will beep to indicate that it has received a signal and memory slot #4 has been filled.
8. Press the *Open/On* button on the third transmitter again. The receiver will beep twice to indicate that it has received a signal, and memory slot #5 has been filled. The double beep also indicates that the receiver has exited programming mode.
9. Verify the tarp system *Open* and *Close* operations are functioning correctly on all three transmitters.
10. Refasten the receiver cover to motor assembly.

Perform the following steps to change your 3500 Series Electric system to a manual crank operation:

NOTE: Store manual crank arm in truck or mounted to trailer.
(Example - above kingpin in the apex.)

STEP 1: Close tarp, letting roll tube hang loose under latchplate.

HEAVY-DUTY MOTOR

STEP 2A: At front of trailer, remove 3/8" x 2 1/4" cap screw and nut from motor shaft and roll tube extension connection.

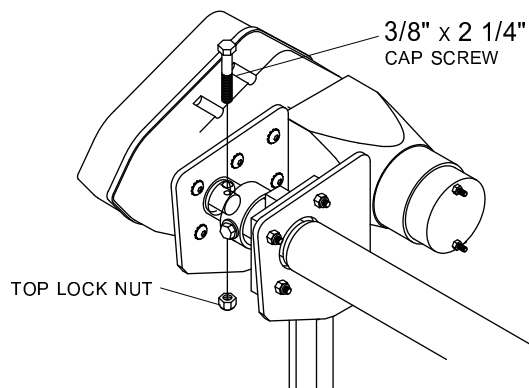

LIGHT-DUTY MOTOR

STEP 2B: At front of trailer, remove 5/16" x 2" cap screw and nut from motor shaft and roll tube extension connection.

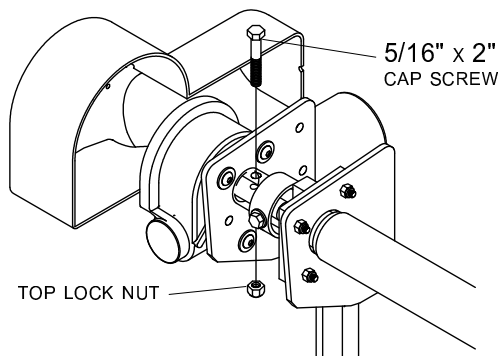

CAUTION

Do not open or close tarp without U-joint securely fastened to splined shaft with wire lock pin. Failure to do so could result in injury.

STEP 3: Remove protective cap and install crank arm assembly as shown in Shur-Lok® owner's manual. View owner's manual at <http://www.shurco.com>.

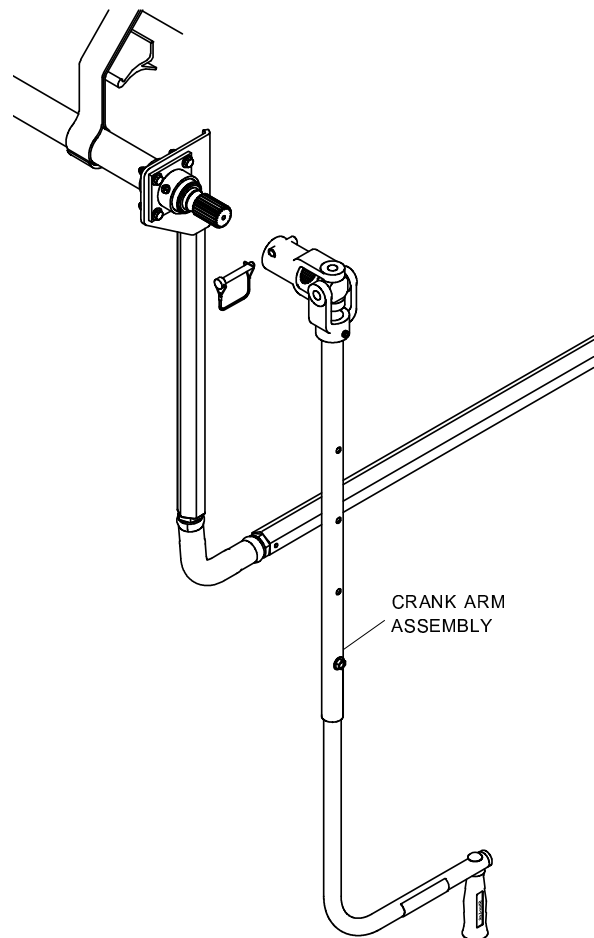

NOTE: Read entire page before drilling holes. Determine if rivets are centered or off center on front and rear of trailer.

NOTE: Pages 24 to 30 are for reverse roll systems.

NOTE: Use pivot bracket washers **BB** only when horizontal corrugation on trailer skin prevents bracket from contacting trailer skin (see instructions on page 2).

FRONT OF TRAILER

STEP 1: Locate front pivot mount bracket on driver side of trailer so center of pivot lies within shaded area shown below. Measure 42" down from top of cap or 44" from top of windshield.

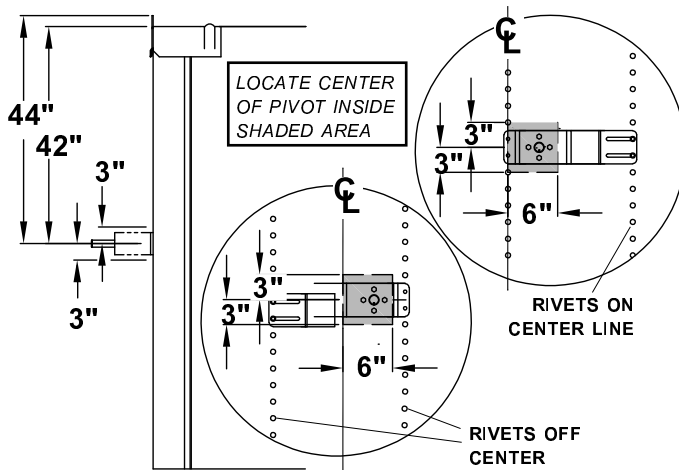

REAR OF TRAILER

STEP 2: Locate rear pivot mount bracket so center of pivot lies within shaded area shown below.

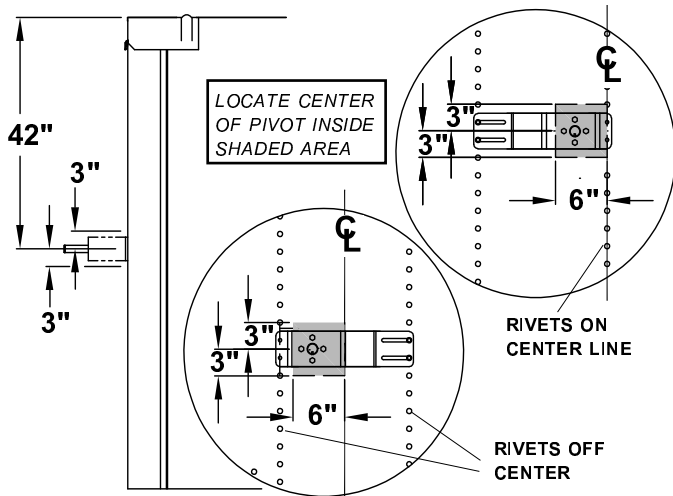

NOTE: Mount brackets into support braces on trailer if possible. If bracket cannot be mounted into support braces, reinforce mounting area with backer plate for adequate support.

Before drilling any holes, make sure flex arm has a clear pathway to operate.

STEP 3: Place pivot mount brackets on trailer in orientation shown below. Using brackets as guide, mark mounting hole locations.

FRONT OF TRAILER

RIVETS/CORRUGATION ON CENTER

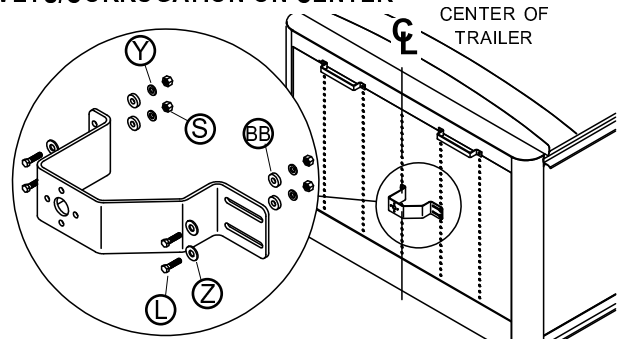

RIVETS/CORRUGATION OFF CENTER

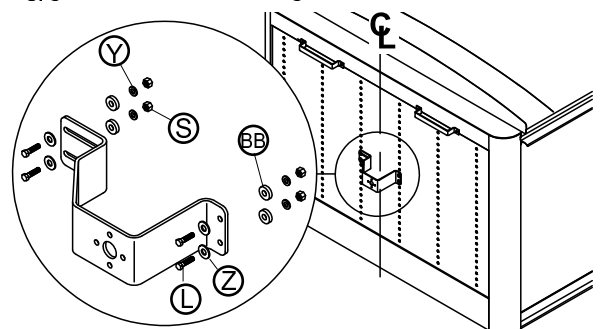

REAR OF TRAILER

RIVETS/CORRUGATION ON CENTER

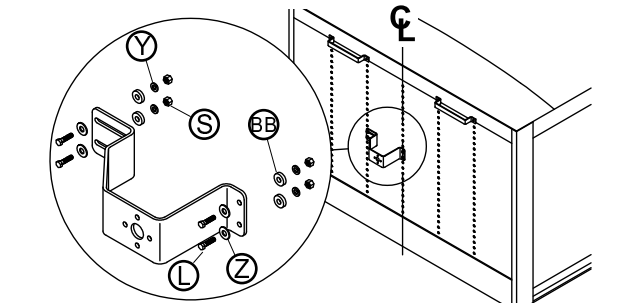

RIVETS/CORRUGATION OFF CENTER

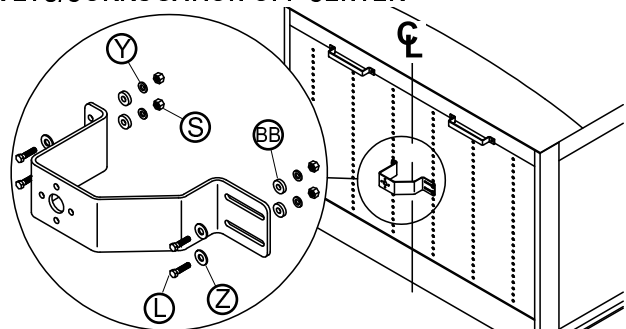

STEP 4: Remove rivets and mount brackets into rivet holes. If this is not possible, drill 13/32" holes in trailer. Fasten with 3/8" x 1 1/4" cap screws, flat washers, lock washers and nuts.

NOTE: Read entire page before drilling holes. Determine if rivets are centered or off center on front and rear of trailer.

FRONT OF TRAILER

STEP 1: Locate sloped pivot mount bracket 42" down from top of cap or 44" from top of windshield, measuring vertically as shown. Do not measure along slope of trailer.

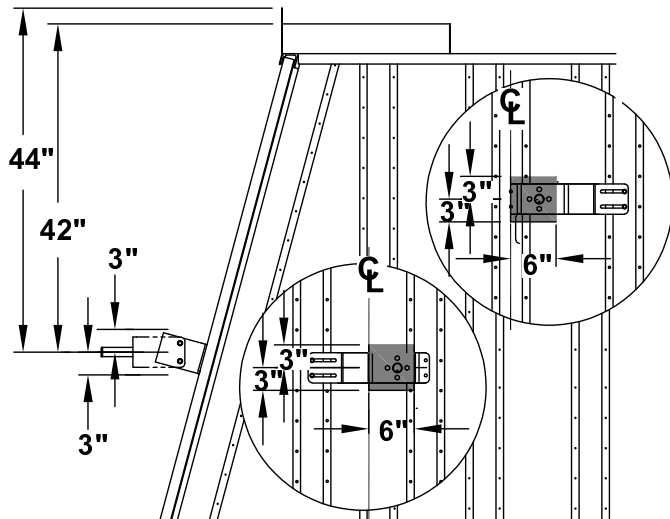

REAR OF TRAILER

STEP 2: Locate sloped pivot mount bracket 42" below top of cap, measuring vertically as shown. Do not measure along slope of trailer.

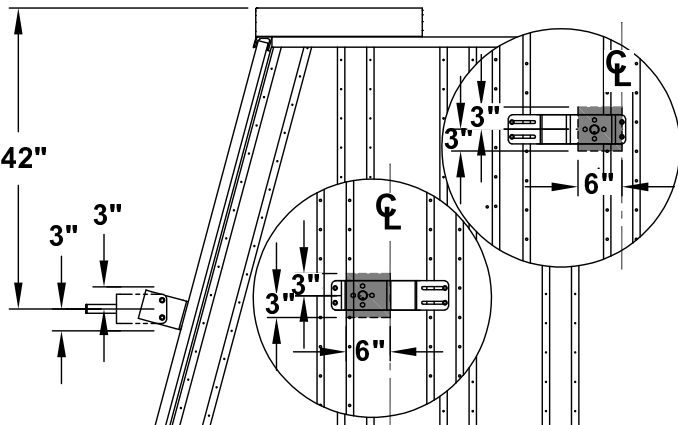

NOTE: Mount brackets into support braces on trailer if possible. If bracket cannot be mounted into support braces, reinforce mounting area with backer plate for adequate support. If bracket does not sit flush with skin of trailer, install spacers between mounting bracket and skin of trailer to assure solid contact through support braces or backer plate. Before drilling any holes, make sure flex arm has a clear pathway to operate.

NOTE: Use pivot bracket washers **BB** only when horizontal corrugation on trailer skin prevents bracket from contacting trailer skin (see instructions on page 2).

STEP 3: Place pivot mount brackets on trailer in orientation shown below. Using brackets as guide, mark mounting hole locations.

FRONT OF TRAILER

RIVETS/CORRUGATION ON CENTER

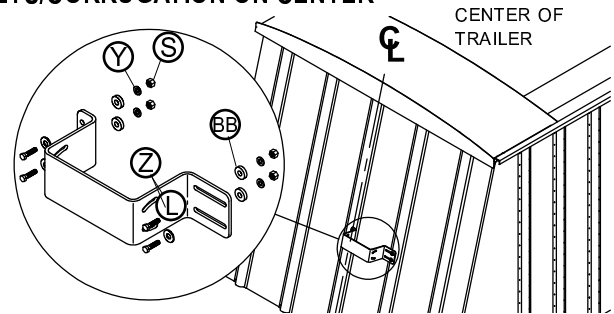

RIVETS/CORRUGATION OFF CENTER

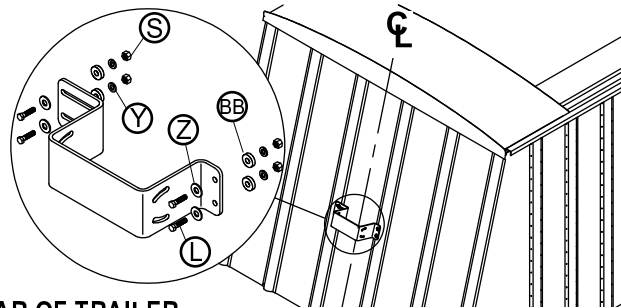

REAR OF TRAILER

RIVETS/CORRUGATION ON CENTER

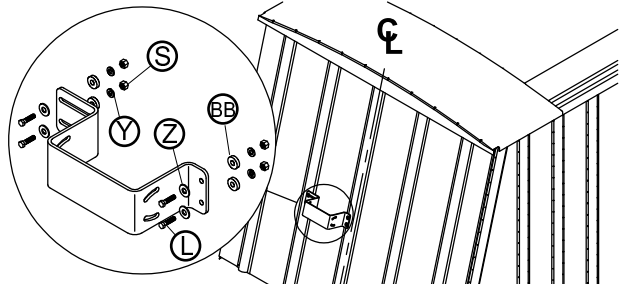

RIVETS/CORRUGATION OFF CENTER

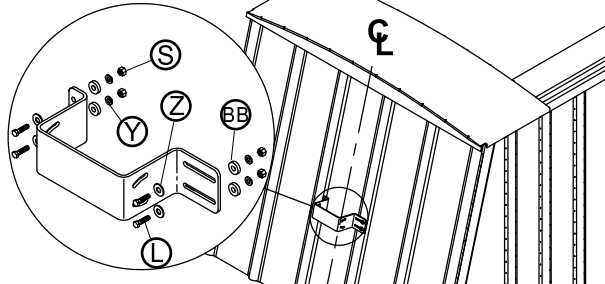

STEP 4: Drill 13/32" holes in trailer. Fasten sloped pivot mount bracket to trailer with 3/8" x 1 1/4" cap screws, flat washers, lock washers and nuts.

STEP 5: Place pivot brackets on pivot mount brackets in orientation shown below. Fasten pivot brackets to pivot mount brackets with 3/8" x 1 1/4" cap screws, flat washers, lock washers and nuts.

FRONT OF TRAILER

RIVETS/CORRUGATION ON CENTER

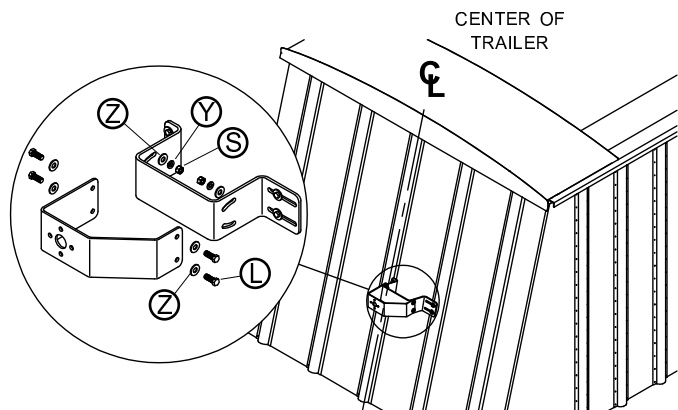

REAR OF TRAILER

RIVETS/CORRUGATION ON CENTER

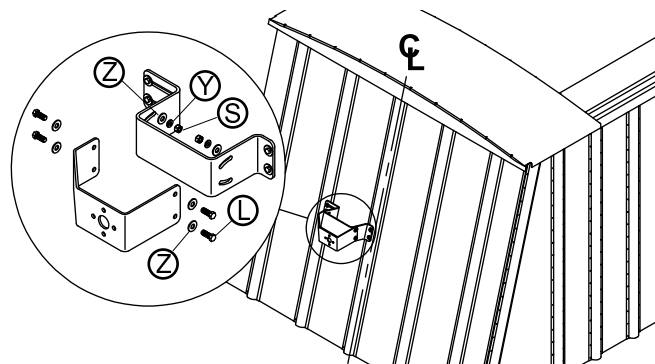

RIVETS/CORRUGATION OFF CENTER

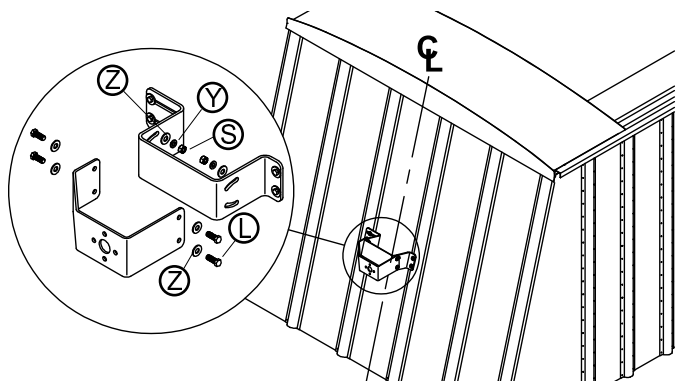

RIVETS/CORRUGATION OFF CENTER

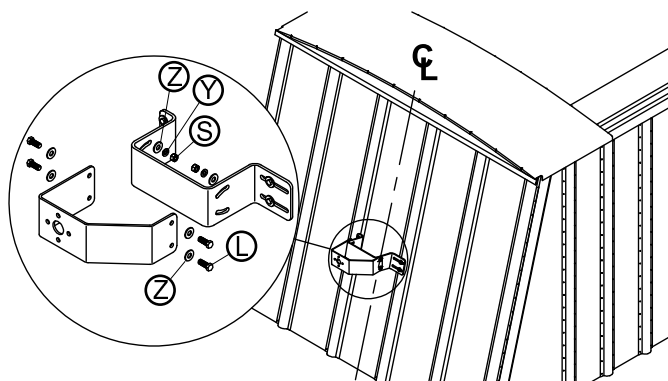

Item	Part #	Description
1.	1703135	Heavy-Duty Motor
2.	1110408	Flange Bearing
3.	1119373	Upper Flex Arm - Motor Side - RR
4.	1116924	Manual Override Collar
5.	1117497	Roll Tube Ext. w/Drive Shaft - Sloped
6.	1703869	Sleeve Bearing - 1" x 1 1/4"
7.	1703823	Light-Duty Motor
8.	1111027	Spiral Torsion Spring
9.	1703882	Cap Plug w/Hole - 1 1/4"
10.	1703873	Flex Arm Joint
11.	1116905	Lower Flex Arm
12.	1702888	Retaining Ring - 1 1/4"
13.	1703822	Dual-Cond. Wire 6 Ga. - 259 Strand
14.	1117033	Spacer Tube - .35" x 2 5/8"
15.	1703282	Rubber Grommet - 1 1/4" Insert

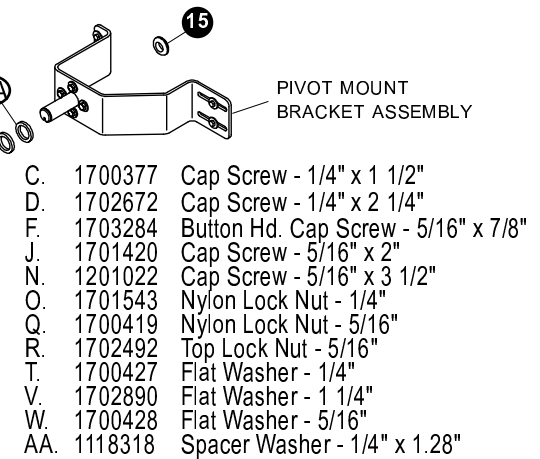
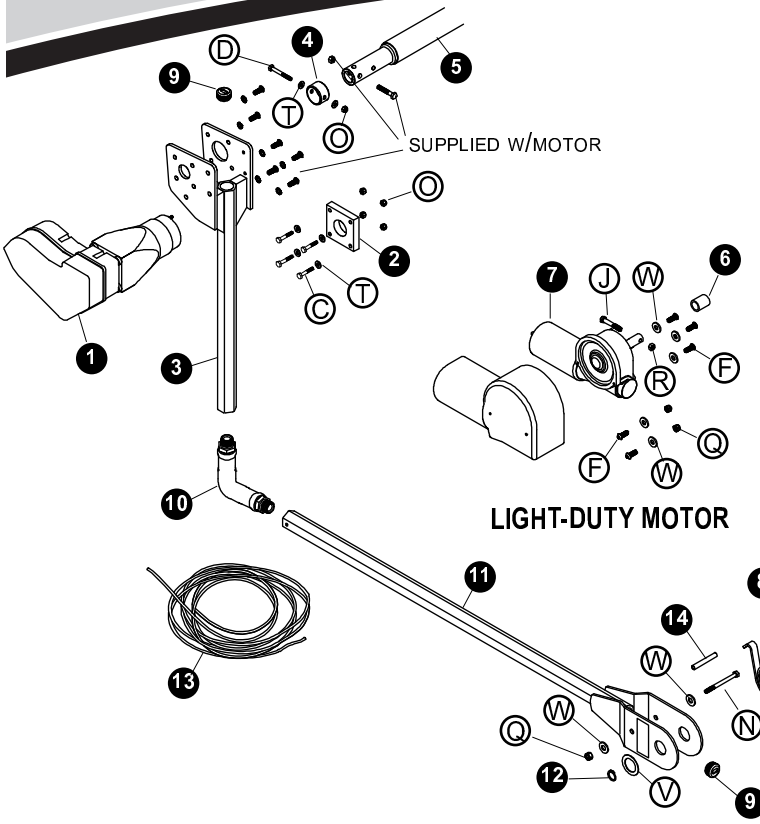

STEP 1: Install cap plug with hole on lower flex arm. Fasten spacer tube into spring support bracket on lower flex arm with 5/16" x 3 1/2" cap screw, two flat washers and nylon lock nut.

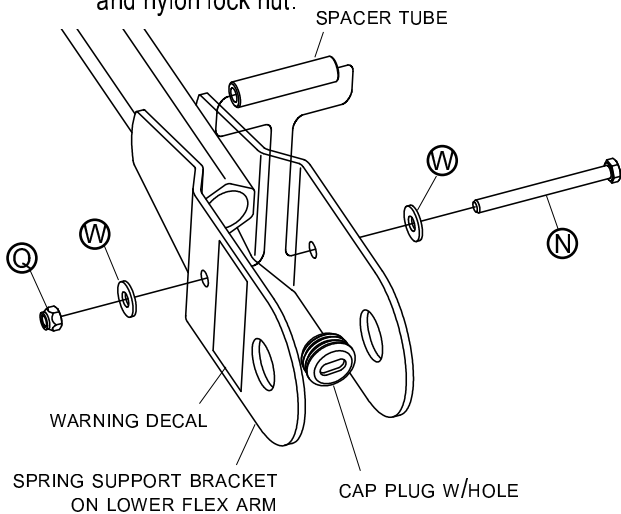

NOTE: Insert cap screw through flex arm so head of screw will be on inside of assembly (toward trailer). Warning label must be in plain view on outside of assembly.

STEP 2: Assemble spacer washers onto pivot pin.

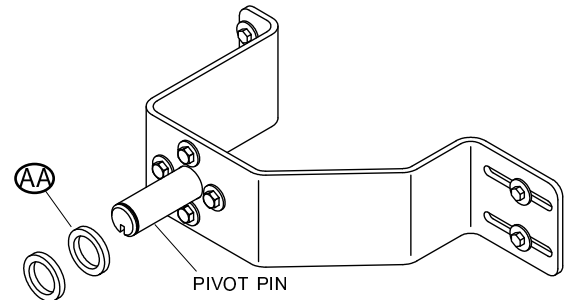

STEP 3: Assemble spiral torsion springs and lower flex arm onto pivot pin. Hook springs over 3/8" x 3 1/2" cap screw and spacer tube.

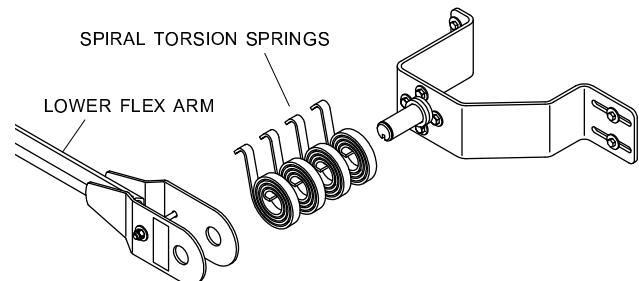

STEP 4: Secure with 1 1/4" flat washer and retaining ring.

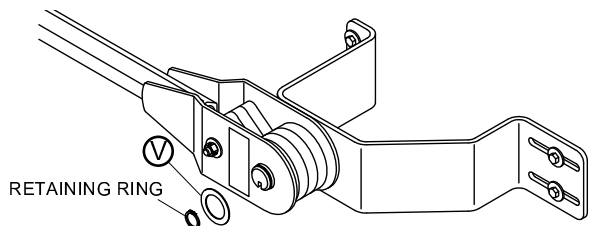

STEP 5: Insert wire (black with red stripe) through lower flex arm and flex arm joint. Thread flex arm joint into lower flex arm. Hand tighten only.

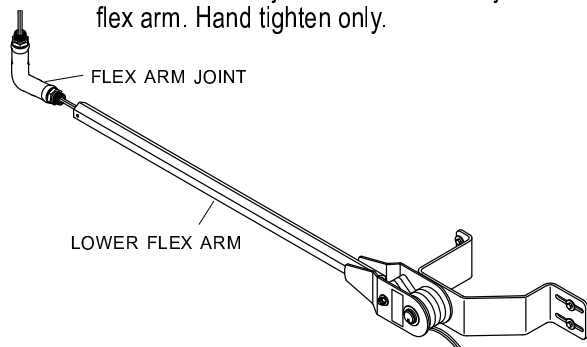

STEP 6: Insert wire through upper flex arm, then thread upper flex arm on to flex arm joint. Hand tighten only.

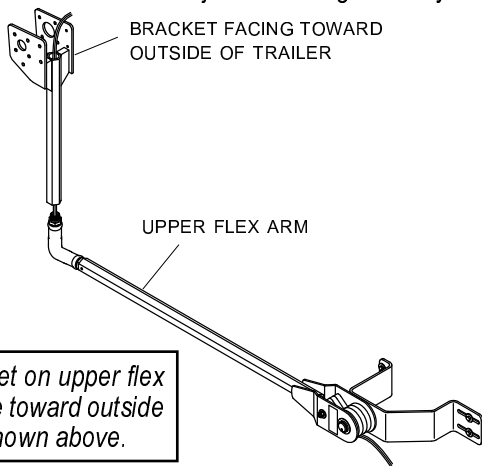

NOTE: Bracket on upper flex arm must face toward outside of trailer as shown above.

STEP 7: Drill 1 1/8" hole below pivot mount bracket. Press rubber grommet into hole and insert wire through grommet, leaving enough slack in wire to allow arm to travel.

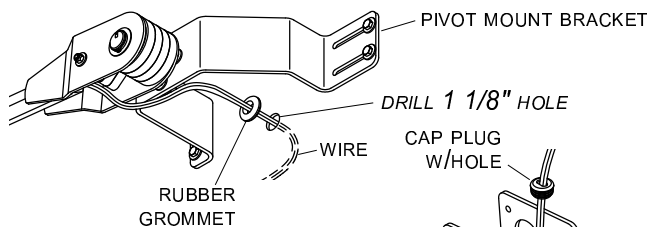

STEP 8: Install cap plug with hole on upper flex arm. Leave about 12" of wire extending out of flex arm.

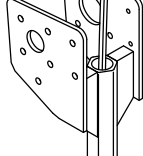

STEP 9: Mount electric motor to upper flex arm. For heavy-duty motor, use 5/16" button head cap screws and star washers supplied with motor. Light-duty motor - use 5/16" button head cap screws and flat washers.

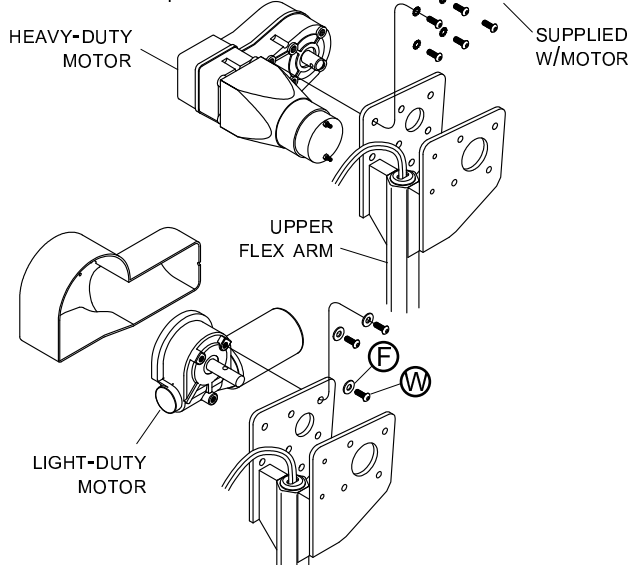

ATTENTION - FOR HEAVY-DUTY MOTOR:

- Use all mounting bolts when mounting gear motor.
- Do not use power tools.
- Do not overtighten (torque 5/16" x 7/8" Button Hd. Bolts to 70 in/lbs).
- Over tightening may crack case.
- Install star washers on the bolt side of the mounting plate.
- Do not use any form of thread locker.

STEP 10: Mount bearing flange to upper flex arm bracket with 1/4" x 1 1/2" cap screws, washers and nuts. **Finger tighten only to allow for adjustment.**

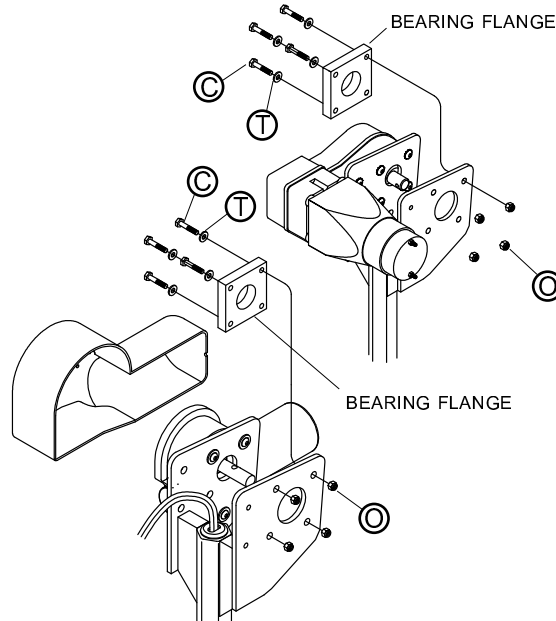

Item	Part #	Description
1.	1118309	Flange Bearing - 2"
2.	1703881	Cap Plug - 1 1/4" x 14-16 Ga.
3.	1119374	Upper Flex Arm - Bearing Side - RR
4.	1704352	Rear Arm Retaining Collar
5.	1700789	Protective Cap
6.	1111027	Spiral Torsion Spring
7.	1702888	Retaining Ring - 1 1/4"
8.	1116905	Lower Flex Arm
9.	1703873	Flex Arm Joint
10.	1117033	Spacer Tube - .35" x 2 5/8"
A.	1704353	Self-Drilling Screw - 1/4" x 1"
H.	1703487	Cap Screw - 5/16" x 1 1/2"
N.	1201022	Cap Screw - 5/16" x 3 1/2"
Q.	1700419	Nylon Lock Nut - 5/16"
T.	1700427	Flat Washer - 1/4"
V.	1702890	Flat Washer - 1 1/4"
W.	1700428	Flat Washer - 5/16"
AA.	1118318	Spacer Washer - 1/4" x 1.28"

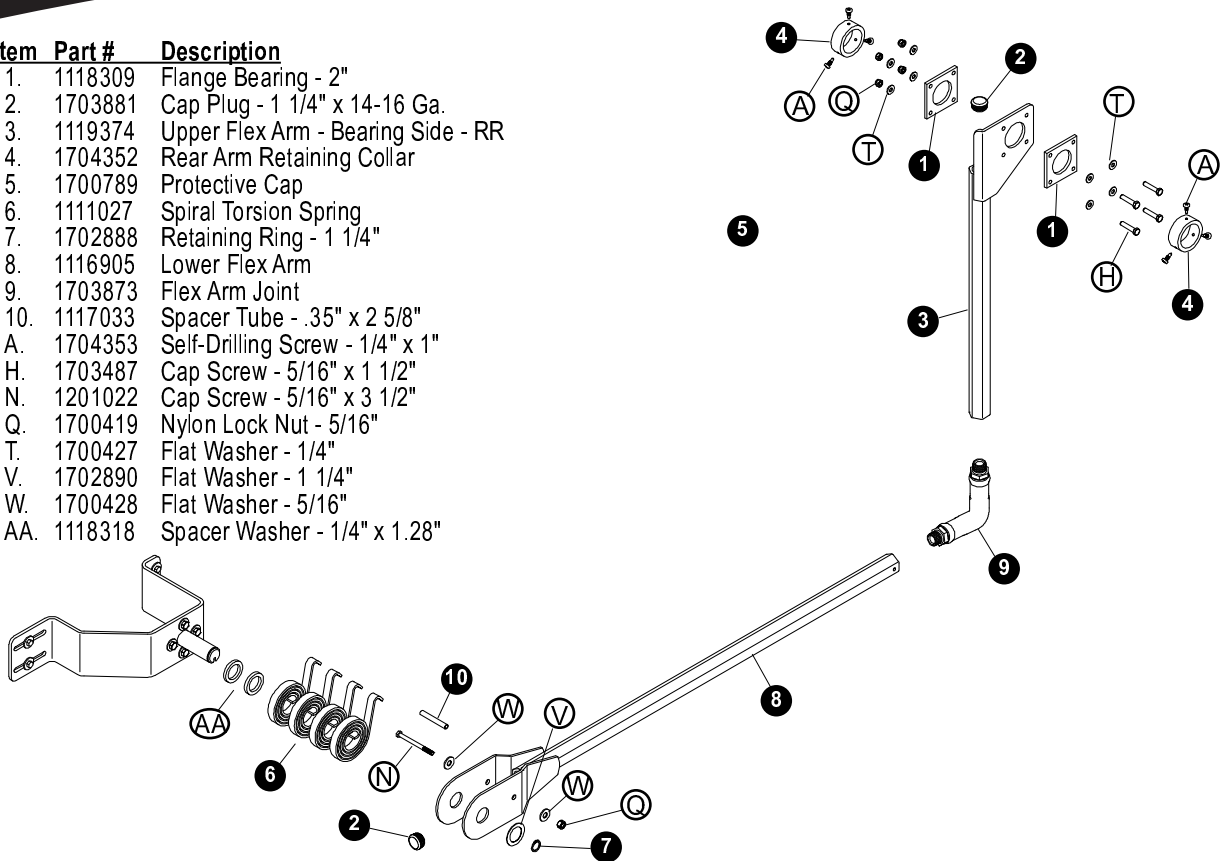

STEP 1: Install cap plug on lower flex arm. Fasten spacer tube into spring support bracket on lower flex arm with 5/16" x 3 1/2" cap screw, two flat washers and nylon lock nut.

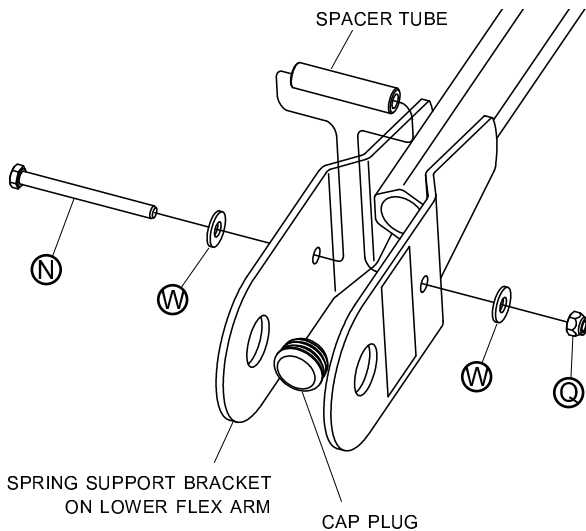

STEP 2: Assemble spacer washers on to pivot pin.

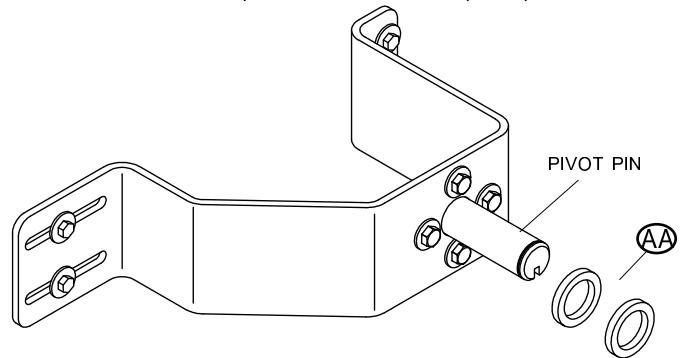

STEP 3: Assemble spiral torsion springs and lower flex arm on to pivot pin. Hook springs over 3/8" x 3 1/2" cap screw.

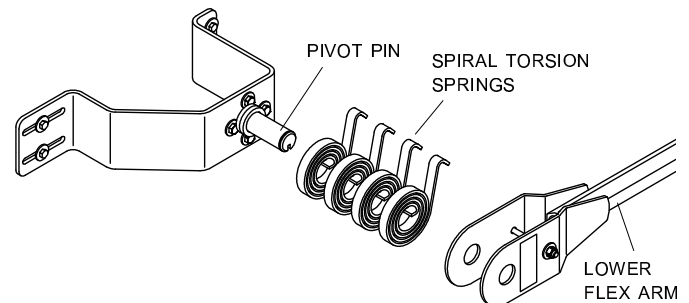

NOTE: Insert cap screw through flex arm so head of screw will be on inside of assembly (toward the trailer). Warning label must be in plain view on outside of assembly.

STEP 4: Secure with 1 1/4" flat washer and retaining ring.

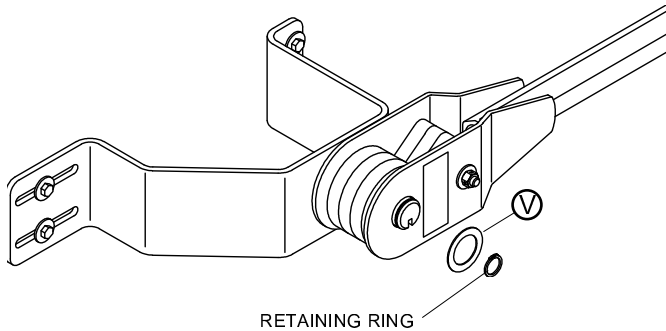

STEP 5: Install cap plug on rear upper flex arm.

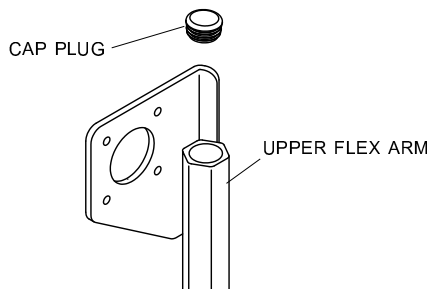

STEP 6: Thread flex arm joint into lower flex arm, then into upper flex arm. Hand tighten only.

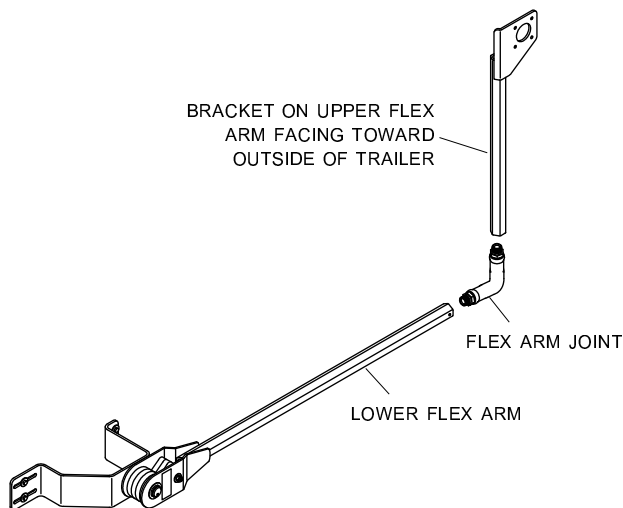

NOTE: Bracket on upper flex arm must face toward outside of trailer as shown above.

NOTE: Go to page 13 to continue installing your reverse roll 3500 tarping system.

STEP 7: Fasten bearing flanges to upper flex arm with 5/16" x 1 1/2" cap screws, flat washers and lock nuts as shown. Finger tighten only to allow for adjustment.

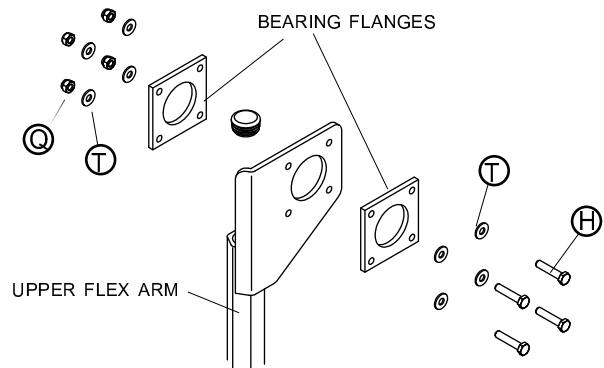

NOTE: Replace system parts only with Genuine Shur-Co® parts to ensure proper system function. If Genuine Shur-Co® parts are not used, warranty could be void.

FRONT

Item	Part #	Description
1.	1700419	Nylon Lock Nut - 5/16"
2.	1700429	Flat Washer - 3/8"
3.	1700407	Hex Nut - 3/8"
4.	1700434	Lock Washer - 3/8"
5.	1116920	Pivot Pin - 4 Spring
6.	1116919	Vertical Pivot Mount Bracket - 7 1/4" Standoff
	1117031	Vertical Pivot Mount Bracket - 9 1/4" Standoff
7.	1702891	Cap Screw - 3/8" x 1 1/4"
8.	1118318	Spacer Washer - 1/4" x 1.81" x 1.28"
9.	1111027	Spiral Torsion Spring - 1 1/4" Pins
10.	1201022	Cap Screw - 5/16" x 3 1/2"
11.	1702890	Flat Washer - 1 1/4"
12.	1702888	Retaining Ring - 1 1/4"
13.	1116905	Lower Flex Arm
14.	1703873	Flex Arm Joint
15.	1703135	Heavy-Duty Motor
16.	1110408	Flange Bearing
17.	1118015	Upper Flex Arm - Motor Side
	1119373	Upper Flex Arm - Motor Side - Reverse Roll
18.	1703882	Cap Plug w/Hole - 1 1/4" x 14-16 Ga.
19.	1116924	Manual Override Collar
20.	1117497	Roll Tube Extension w/Drive Shaft - 36.94"
	1119433	Roll Tube Extension w/Drive Shaft - 28.88"
21.	1702672	Cap Screw - 1/4" x 2 1/4"
22.	1701543	Nylon Lock Nut - 1/4"
23.	1700427	Flat Washer - 1/4"
24.	1700377	Cap Screw - 1/4" x 1 1/2"
25.	1117033	Spacer Tube - .35" x 2 5/8"
26.	1700428	Flat Washer - 5/16"
27.	1120291	Pivot Bracket Washer
28.	1703823	Light Duty Motor
29.	1701420	Cap Screw - 5/16" x 2"
30.	1703869	Sleeve Bearing - 1" x 1 1/4"
31.	1702492	Top Lock Nut - 5/16"
32.	1700428	Flat Washer - 5/16"
33.	1703284	Button Hd. Cap Screw - 5/16" x 7/8"

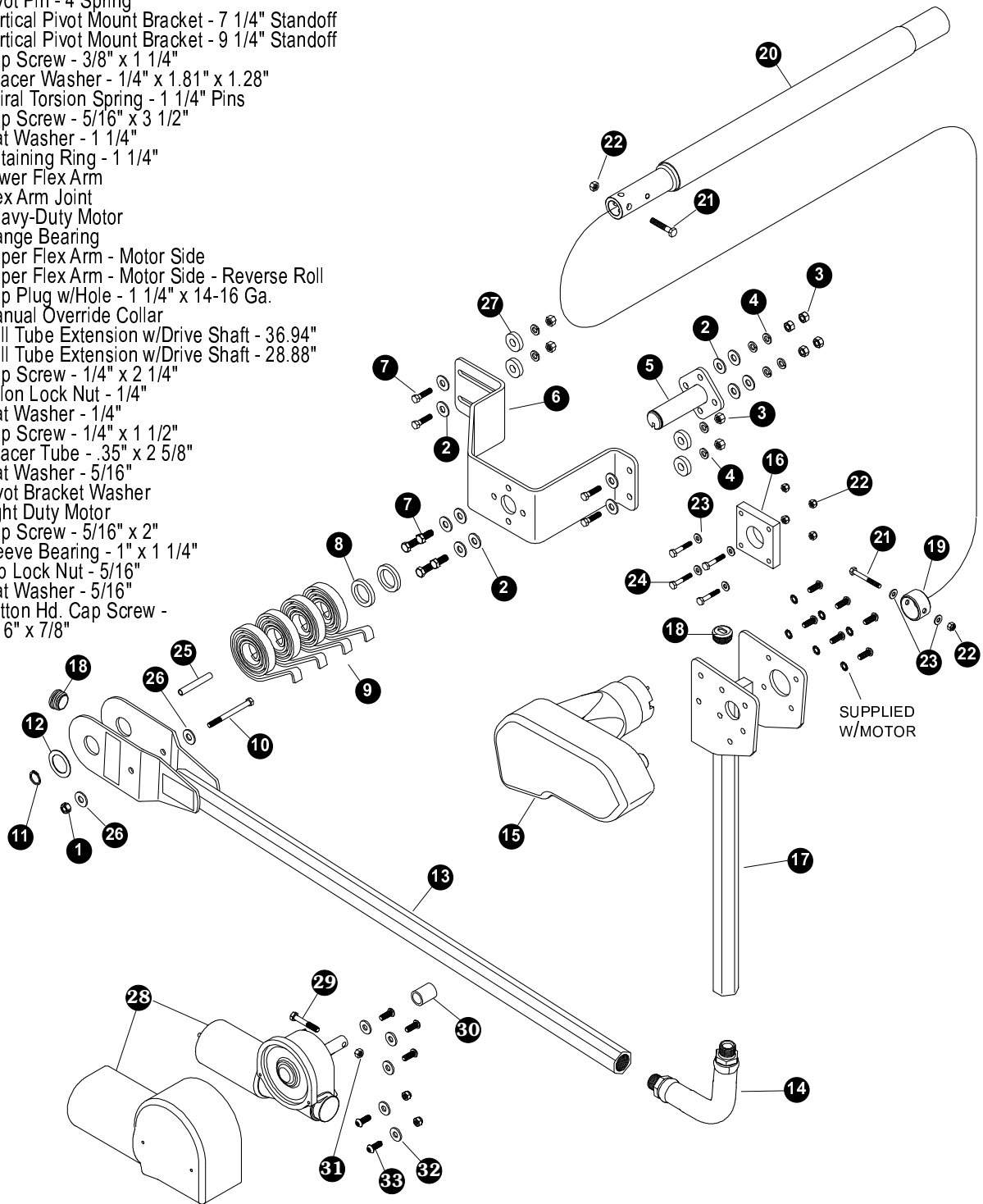

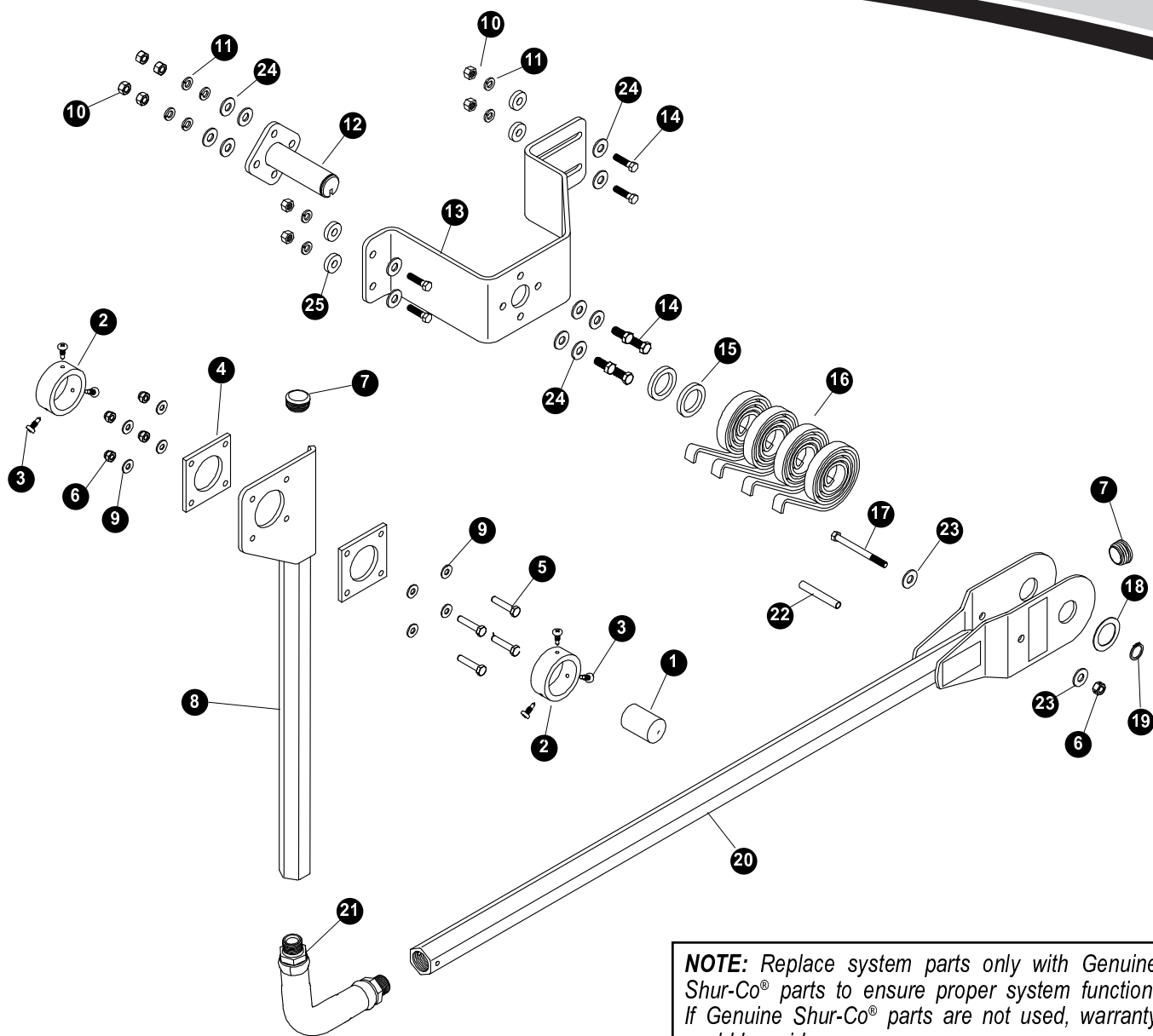

REAR

Item	Part #	Description
1.	1700789	Protective Cap
2.	1704352	Rear Arm Retaining Collar
3.	1704353	Self-Drilling Screw - 1/4" x 1"
4.	1118309	Flange Bearing - 2"
5.	1703487	Cap Screw - 5/16" x 1 1/2"
6.	1700419	Nylon Lock Nut - 5/16"
7.	1703881	Cap Plug - 1 1/4" x 14-16 Ga.
8.	1117442	Upper Flex Arm - Bearing Side
	1119374	Upper Flex Arm - Bearing Side - Reverse Roll
9.	1700427	Flat Washer - 1/4"
10.	1700407	Hex Nut - 3/8"
11.	1700434	Lock Washer - 3/8"
12.	1116920	Pivot Pin - 4 Spring

Item	Part #	Description
13.	1116919	Vertical Pivot Mt. Bracket - 7 1/4" Stand-off
	1117031	Vertical Pivot Mt. Bracket - 9 1/4" Stand-off
14.	1702891	Cap Screw - 3/8" x 1 1/4"
15.	1118318	Spacer Washer - 1/4" x 1.8" x 1.28"
16.	1111027	Spiral Torsion Spring
17.	1201022	Cap Screw - 5/16" x 3 1/2"
18.	1702890	Flat Washer - 1 1/4"
19.	1702888	Retaining Ring - 1 1/4"
20.	1116905	Lower Flex Arm
21.	1703873	Flex Arm Joint
22.	1117033	Spacer Tube - .35" x 2 5/8"
23.	1700428	Flat Washer - 5/16"
24.	1700429	Flat Washer - 3/8"
25.	1120291	Pivot Bracket Washer

3500 ELECTRIC COMPONENTS

Item	Part #	Description
	1116473	Cab Wiring Kit - Rocker Switch
	1116928	Cab Wiring Kit - SMARTransmitter®
	1116929	Trailer Wiring Kit - SMARTransmitter®
	1116930	Trailer Wiring Kit - Rocker Switch
	1118368	Electric Parts Kit w/Rocker Switch - 40-Amp Mod.
	1118257	Shur-Co® Wireless Receiver
1.	1703245	Ring Terminal - 6 Ga. x #10 Stud - Motor/Breaker
2.	1703244	Ring Terminal - 6 Ga. x 3/8" Stud - Battery
3.	1704153	Ring Terminal - 14 Ga. x 1/4" Stud - Solenoid
4.	1703659	Push On Terminal - 14 Ga. 1/4" - Switch/Solenoid
5.	1702707	Ring Terminal - 6 Ga. 1/4 Stud - Motor/Solenoid
6.	1118437	5-Channel SMARTransmitter® Battery
	1704597	SMARTransmitter® Replacement Battery
7.	1704330	Rubber Boot
8.	1704308	Cap Screw - #10 x 1/2"
9.	1120695	Motor Reversing Solenoid - RF
10.	1704343	Cap Screw - 1/4" x 1 1/2"
11.	1700408	Hex Nut - 1/4"
12.	1700427	Flat Washer - 1/4"
13.	1118296	Modular Control Bracket
14.	1118297	Insulating Plate
15.	1703282	Rubber Grommet - 1 1/4" Insert
16.	1701595	End Plug - 1" x 14-23 Ga.
17.	1118037	Black Plastic Washer
18.	1118250	Orange Plastic Washer
19.	1700436	Lock Washer - 1/4"
20.	1118340	Solenoid Cover/Gasket
21.	1704369	Trim Seal
22.	1703822	Dual Conductor Wire - 6 Ga. 259-Strand
23.	1116482	Electrical Wire - 14 Ga. 3 Lead - 15'
24.	1704354	40-Amp Modified Reset Circuit Breaker
25.	1116020	Rocker Switch
26.	1703661	Rocker Switch Mounting Bracket
27.	1703231	Cable Tie - 8"
28.	1703845	Motor Reversing Solenoid
29.	1703896	Solenoid Cover
30.	1700381	Cap Screw - 1/4" x 1"
31.	1701543	Nylon Lock Nut - 1/4"
32.	1115385	Heavy-Duty Dual Conductor Plug
33.	1119557	Heavy-Duty Dual Conductor Socket
	1704573	Conductor Socket Sealing Boot
34.	1700407	Hex Nut - 3/8"
35.	1700434	Lock Washer - 3/8"
36.	1700411	Hex Nut - 5/16"
37.	1701045	Cap Screw - 5/16" x 3/4"
38.	1109015	Mounting Bracket
39.	1700400	Self-Tapping Screw - 3/8" x 1"
40.	1702108	Wire Clip - 3/4"
41.	1704338	Self-Tapping Screw - 1/4" x 1"

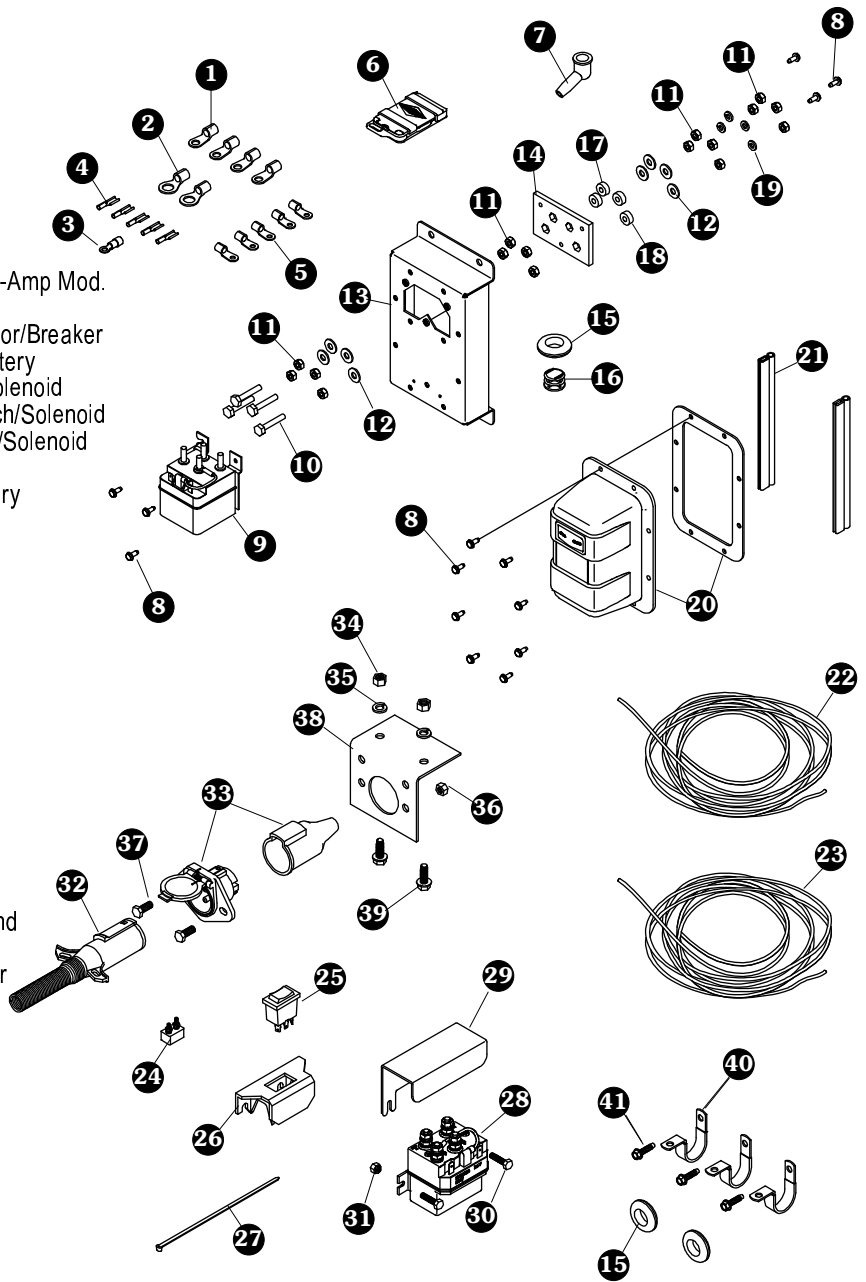

SLOPED PIVOT MOUNT

Item	Part #	Description
1.	1700429	Flat Washer - 3/8"
2.	1700407	Hex Nut - 3/8"
3.	1700434	Lock Washer - 3/8"
4.	1116920	Pivot Pin - 4 Spring
5.	1702891	Cap Screw - 3/8" x 1 1/4"
6.	1120361	Pivot Backer Plate - 5" x 16"
	1120418	Pivot Backer Plate - 5" x 20"
7.	1116922	Sloped Pivot Mount Bracket - 6" Standoff
	1117580	Sloped Pivot Mount Bracket - 8" Standoff
8.	1116923	Sloped Pivot Bracket
9.	1700400	Self-Tapping Screw - 3/8" x 1"
10.	1120291	Pivot Bracket Washer

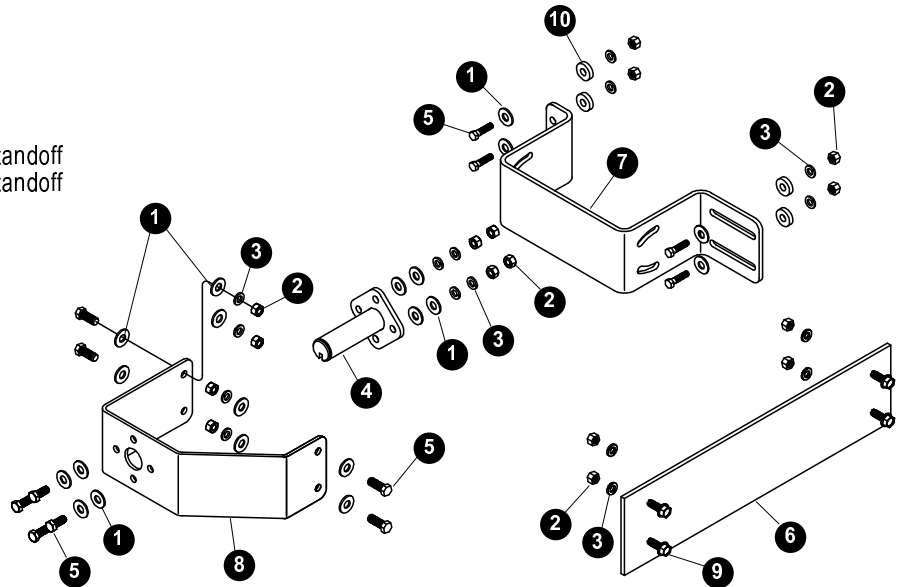

Our **Advanced Troubleshooting Guide** is available on our website: <http://www.shurco.com>, or call our Help Line: **1-866-748-7435**.

PROBLEM:	TRY THIS:
<p>The SMARTransmitter® is not working.</p> <p>None of the lights on the remote turn on when I open the lid.</p>	<ol style="list-style-type: none"> 1. Make sure the battery is placed correctly. 2. The battery may be dead and must be replaced. Replacement high-capacity SMARTransmitter® batteries may be purchased from Shur-Co® (part # 1704597). 3. The SMARTransmitter® may be damaged. Call Shur-Co's Help Line.
<p>The SMARTransmitter® is not working.</p> <p>I can operate the system with the rocker switch but not with the remote. The SMARTransmitter® channel light (<i>Tarp System</i>, for example) is blinking and when I press the <i>Open/On</i> button, the light blinks faster.</p>	<ol style="list-style-type: none"> 1. Make sure the remote is set to the right channel. If you cannot set the remote to the desired channel (<i>Tarp System</i>, for example), the remote must be reprogrammed. See the SMARTransmitter® programming instructions. 2. Make sure you are within a couple feet of the receiver and try again. <ol style="list-style-type: none"> a) If it works at short range but not at greater distances, you have a range problem. A new battery may be needed. If the remote battery is not the cause, call Shur-Co's Help Line. 3. Reprogram the receiver. See the receiver programming instructions. If this doesn't work, call Shur-Co's Help Line.
<p>The system will not operate with the rocker switch or with the SMARTransmitter®.</p> <p>When I try to use the rocker switch or SMARTransmitter®, I don't hear any noises (a clicking noise, for example) from the receiver</p>	<ol style="list-style-type: none"> 1. Make sure the master disconnect switch is turned to the "ON" position. 2. The circuit breaker may have tripped. Wait one minute and try again. 3. Check the vehicle's battery to make sure it isn't dead. 4. Check all connections from the battery to the system. Check for polarity, good connections and corrosion. Verify that you have at least 12V on the back side of the receiver on the battery hookup posts. 5. Call Shur-Co's Help Line.
<p>The system will not operate with the rocker switch or with the SMARTransmitter®.</p> <p>When I try to use the rocker switch or SMARTransmitter®, I hear a clicking noise, but nothing happens.</p>	<ol style="list-style-type: none"> 1. Verify that you have at least 12V on the back side of the receiver on the battery hookup posts. 2. Call Shur-Co's Help Line.
<p>The rocker switch is not sticking, but the motor continues to run after I release the rocker switch.</p>	<ol style="list-style-type: none"> 1. Call Shur-Co's Help Line.
<p>The rocker switch is sticking.</p>	<ol style="list-style-type: none"> 1. Check the switch for excessive dirt, rocks or other objects. If the rocker switch cannot be cleaned, call Shur-Co's Help Line for a replacement receiver. <p>Pressure wash: The receiver may be pressure washed, but keep nozzle at least three feet from system while spraying.</p>

Our **Advanced Troubleshooting Guide** is available on our website: <http://www.shurco.com>, or call our Help Line: **1-866-748-7435**.

MORE QUALITY PRODUCTS FROM SHUR-CO®

- **Genuine Replacement Tarps**
- **Genuine Replacement Parts**

- **Agriculture Products**
 - Value Series Shur-Lok®
 - Super Duty Shur-Lok®
 - Shur-Lok® Junior
 - Premium Belt 'n Ratchet
 - Cable-Lok™
 - Turning Point™ Bow

- **SMARTrailer™ Accessories for Agriculture Products**
 - SMART2™ Remote
 - SMART1 +™ Remote
 - 4500 Series HD Electric
 - Electric Shur-Lok®
 - AutoTrap™ Hopper Opener
 - ProTrap® Hopper Opener
 - Electric Gate & Hoist
 - LiteALL™ Work Lights
 - Cable-Lok™ Electric Upgrade
 - Electric Turning Point™ Bow
 - Solar Power Pack

- **Flatbed Products**
 - ShurTite™ Retractable Tarps
 - Stock Lumber & Steel Tarps

- **Custom Products**
 - Fitted Truck Covers
 - Flat Utility Tarps
 - Bean Drill Covers
 - Shur-Lok® Tarp Cords
 - Gustbuster™ Tarp Cords

- **Construction Products**
 - Super Duty Shur-Lok®
 - Shur-Trak II™
 - Cover-Pro II®
 - Turning Point™ Bow
 - IronSide™ Side-Dump System
 - Arm-Matic™
 - DuraPull™
 - Econo-Pull™
 - Turbo Tarp2™
 - 2000 Series
 - 5000 Series
 - Hammer™
 - Bullet™
 - Flash™
 - Long Arm™

- **SMARTrailer™ Accessories for Construction Products**
 - 4500 Series HD Electric w/Gate Flex™
 - Shur-Trak II™ Electric Upgrade
 - Cover-Pro II® Electric Upgrade
 - Electric Turning Point™ Bow
 - Solar Power Pack

- **Waste Products**
 - The Ox™
 - Quick-Flip III™
 - Sidewinder™
 - Sidewinder™ 350
 - HyTower™ SL
 - HyTower™ DL
 - Double-Flip™

TARPING SYSTEMS & ACCESSORIES

