



TARPING SYSTEMS & ACCESSORIES

P/N 1117014 Rev. U

OWNER'S MANUAL



Aluminum System for End Dump

READ BEFORE INSTALLING

PO BOX 713 ■ 2309 SHUR-LOK STREET ■ YANKTON, SD 57078-0713
PHONE 1-800-4-SHUR-LOK (1-800-474-8756) ■ FAX 605-665-0501
www.shurco.com

SHOP ONLINE: www.shopshurco.com

SHIPPING. Orders are shipped F.O.B. from the Shur-Co®, LLC sites listed below. No full freight is allowed or prepaid shipment accepted unless quoted and approved in writing prior to acceptance of the order. All shipments are made by the most reasonable means in accordance with size and weight of order, unless specified routing instructions are furnished by the customer. Shipments are made daily via U.P.S. and common carrier. Claims for shortages must be made within 10 days. All claims for damages or loss in transit must be made with the carrier. No collect calls will be accepted. To ensure delivery of orders, we need your full street address and phone number. When you receive your shipment, examine it carefully. Be sure all cartons listed on the delivery sheet are accounted for. Large items may be packaged separately. If a carton is damaged, open it and inspect the contents before signing for delivery. If merchandise is damaged, describe damage on the delivery receipt. Failure on your part to document damaged or missing merchandise on the delivery receipt releases the carrier of all liability; repair or replacement will be the customer's responsibility.

WARRANTY. We warrant all new products are free of defects in materials and workmanship.* This warranty is effective if products are properly installed and used for the purpose for which they were intended and applies to the original buyer only. Except as set forth above or in any product-specific warranty documentation, we make no other warranties, express or implied, including but not limited to warranties of merchantability of fitness for a particular use.

Returns of a product for warranty must be accompanied by a Return Merchandise Authorization number (RMA#), obtained by calling Customer Service at 866-748-7435, and sent, with freight paid by us, to Shur-Co®, LLC, 2309 Shur-Lok St., PO Box 713, Yankton, SD 57078. All products returned without an RMA# will be refused. When we issue the RMA#, we will also issue a call tag to have UPS (or other freight company) pick up the product. C.O.D. returns not accepted. We will pay no storage fees for a warranty product return prior to pick by us or the freight company. If a warranty product return is scheduled to be picked up by us, we will pick up the product at our earliest convenience.

If a product returned is found, in our judgement, to be defective in material or workmanship, our obligation under this warranty is limited to the repair or replacement of the product, which will be made by us. Repair or replacement will be at our discretion, with replacements being made using current products performing in the equivalent function. Labor charges, other than those incurred at our factory, including, but not limited to, any labor to install a repaired or replacement product, are not covered under this warranty. All expenses associated with delivering defective products to our factory and delivering repaired or replacement products from our factory to the owner will be paid by us.

If the product returned is found, in our judgement, to be non-warrantable, the owner will be contacted to authorize repair work, purchase of a replacement product or return of the product, all of which will be at the owner's expense. Payment authorization must be received by us before any non-warrantable product is repaired, replaced or returned. All expenses associated with delivering the repaired non-warrantable product, a replacement product or the non-warrantable product from our factory to the owner will be paid by the owner.

In no event will we be liable for any damages of any kind to person, product or property, including but not limited to indirect, incidental, special, consequential or punitive damages, or damages for loss of profits or revenue, even if we have been advised of the possibility of such damages. There are no warranties for used products or products that have been repaired, altered, modified or subjected to misuse, negligence or accident. We will not repair or replace products that fail or malfunction due to ordinary wear and tear, except as expressly noted in a product-specific warranty. Use of non-Shur-Co®, LLC parts in conjunction with Shur-Co®, LLC products will void this product warranty.

*Certain products have specific warranties that differ from this warranty, for example motors and electronics. Product-specific warranty documentation is available for these items. In the event of a conflict between this warranty and a product-specific warranty, the product-specific warranty will govern.

RETURN POLICY. All sales final. See WARRANTY above for return details.

OTHER. All prices, product listings, sizes, weights and manufacturing details are subject to change without notice. No person is authorized to modify the foregoing conditions of sale whatsoever.

SHUR-CO®, LLC SERVICE AND DISTRIBUTION CENTERS

Corporate HQ and Outlet Store

SHUR-CO® of SOUTH DAKOTA
2309 Shur-Lok St., PO Box 713
Yankton, SD 57078-0713
Ph 800.474.8756 | Fax 605.665.0501

ShurTite™ Service Centers

SHUR-CO® of CANADA
490 Elgin St., Unit #1
Brantford, Ontario N3S 7P8
Ph 800.265.0823 | Fax 519.751.3997

SHUR-CO® of SIOUX FALLS
47184 258th St., Suite B
Sioux Falls, SD 57107
Ph 844.573.9322 | Fax 605.543.5469

SHUR-CO® of ILLINOIS
Ph 866.356.0246 | Fax 217.877.8270

SHUR-CO® of OHIO
Ph 866.356.0242 | Fax 330.297.5599

SHUR-CO® of COLORADO
10220 Brighton Rd., Unit #1
Henderson, CO 80640
Ph 866.355.9173 | Fax 303.289.2298

SHUR-CO® of FLORIDA
3353 SE Gran Park Way
Stuart, FL 34997
Ph 800.327.8287 | Fax 772.287.0431

SHUR-CO® of ILLINOIS
3993 E. Mueller Ave.
Decatur, IL 62526
Ph 866.356.0246 | Fax 217.877.8270

SHUR-CO® of IOWA
3839 Midway Blvd.
Ft. Dodge, IA 50501
Ph 866.356.0245 | Fax 515.576.5578

SHUR-CO® of MICHIGAN
5100 Lakeshore Dr.
Lexington, MI 48450
Ph 800.327.8287 | Fax 772.287.0431

SHUR-CO® of NORTH DAKOTA
1746 4th Ave. NW
West Fargo, ND 58078
Ph 877.868.4488 | Fax 701.277.1283

SHUR-CO® of OHIO
1100 N. Freedom, St. Rt. 88 & 14
Ravenna, OH 44266
Ph 866.356.0242 | Fax 330.297.5599

SHUR-CO® of TEXAS
34505 I-10 West, S. Frontage Rd.
Brookshire, TX 77423
Ph 866.689.0039 | Fax 281.934.3311

SHUR-CO® UK, Ltd.
Unit 41 Rochester Airport Estates
Laker Rd., Rochester, Kent ME1 3QX
Ph +44 (0)1795.473499
Fax +44 (0)871.272.8278

For more info, log on to our website:
www.shurco.com

MESSAGE TO OWNERS

Thank you for buying this tarping system from Shur-Co® We appreciate your confidence in our products. Please read and thoroughly understand this manual before installing and/or operating this system.

Pay particular attention to important safety and operating instructions, as well as warnings and cautions. The hazard symbol  is used to alert users to potentially hazardous conditions and is followed by caution, warning or danger messages.

Failure to READ AND FOLLOW INSTRUCTIONS could result in failure of your tarping system and/or personal injury. Your trailer requirements may, however, call for minor variations to these instructions.

Please inspect your tarping system periodically. Repair or replace worn or damaged parts to your system.

QUESTIONS? CALL OUR HELP LINE:

1-866-748-7435

MON-FRI 8 AM-5 PM CENTRAL TIME

SAFETY

We at Shur-Co® are concerned with your safety and the safety of all those operating this system. Therefore, we have provided safety decals at various locations on your tarping system. Keep decals as clean as possible at all times. Replace any decal that has become worn or damaged, painted over or otherwise difficult to read. Replacement decals are available through Shur-Co® dealers.

PARTS INSPECTION

Inspect all parts in your 3500 Series Electric kit upon arrival. Please inspect your tarping system regularly, and repair or replace parts when continued use could damage your system.

SAFETY INSTRUCTIONS

- 1. Always wear safety glasses during installation and operation.**
- 2. Stay clear of moving parts.**
- 3. No other use of this system is authorized, except as designed.**

RUST PREVENTION

To prevent rust, paint all exposed metal, such as weld seams and/or metal exposed by grinding or cutting, with corrosion-resistant paint.





TABLE OF CONTENTS



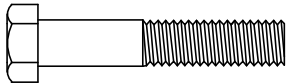
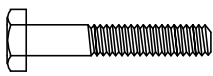
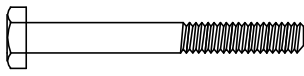
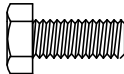
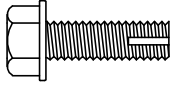
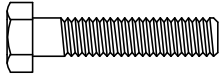
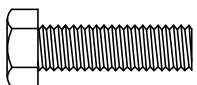
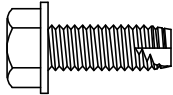
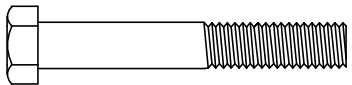
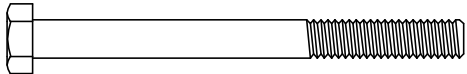

- Hardware Identification..... 1
- Vertical Front Pivot Bracket 2
- Sloped Front Mounting Bracket..... 3
- Sloped Front Pivot Bracket..... 4
- Rear Pivot Bracket..... 5
- Front Flex Arm & Electric Motor 6-7
- Rear Flex Arm..... 8-9
- Roll Tube Extension..... 9-11
- Electric Mounting & Wiring 12-15
- Wireless SMARTransmitter® Programming & Operating..... 16
- Program Wireless SMARTransmitter® to Receiver..... 17
- Change to Manual Power 18
- Replacement Parts 19-21
- Troubleshooting Guide 22-23

TOOLS REQUIRED

- 1. Welder
- 2. Hammer
- 3. Center Punch or Transfer Punch
- 4. #3 Phillips Insert Bit
- 5. Air or Electric Impact Wrench (9/16" deep socket)
- 6. 7/16" Deep Socket
- 7. 3/8" Combination Wrench
- 8. 9/16" Combination Wrench
- 9. 1/2" Combination Wrench
- 10. 1/8" Hex Wrench Long T-Handle
- 11. 3/16" Hex Wrench Long T-Handle (recommended)
- 12. 5/16" Drill Bit (for 3/8" self-tapping screws)
- 13. 13/32" Drill Bit
- 14. 3/8" Drill Bit
- 15. 1/4" Drill Bit
- 16. 17/64" Drill Bit
- 17. 3/8" Drill
- 18. 2" Hole Saw
- 19. Standard/Flathead Screwdriver
- 20. #2 Phillips Screwdriver
- 21. Utility Knife
- 22. Ratchet
- 23. Hack Saw (metal cutter)
- 24. Pliers
- 25. Snap Ring Pliers
- 26. Wire Cutters
- 27. Grinder
- 28. Tape Measure

- A**  1704264 Cap Screw - 3/8" x 2"
- B**  1700377 Cap Screw - 1/4" x 1 1/2"
- C**  1702672 Cap Screw - 1/4" x 2 1/4"
- D**  1701045 Cap Screw - 5/16" x 3/4"
- E**  1701059 Cap Screw - 5/16" x 1"
- F**  1703487 Cap Screw - 5/16" x 1 1/2"
- G**  1702891 Cap Screw - 3/8" x 1 1/4"
- H**  1700400 Self-Tapping Screw - 3/8" x 1"
- J**  1702573 Cap Screw - 3/8" x 2 1/2"
- K**  1201022 Cap Screw - 5/16" x 3 1/2"

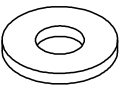
- L**  1700408 Hex Nut - 1/4"
- M**  1701543 Nylon Lock Nut - 1/4"
- N**  1700411 Hex Nut - 5/16"
- O**  1700419 Nylon Lock Nut - 5/16"
- P**  1700407 Hex Nut - 3/8"
- Q**  1700418 Centerlock Nut - 3/8"
- R**  1701580 Nylon Lock Nut - 3/8"

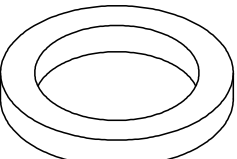
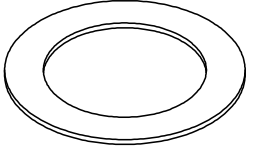
- S**  1700436 Lock Washer - 1/4"
- T**  1700427 Flat Washer - 1/4"
- V**  1700428 Flat Washer - 5/16"
- W**  1700434 Lock Washer - 3/8"
- X**  1700429 Flat Washer - 3/8"
- Y**  1118318 Spacer Washer - 1/4" x 1.81"
- Z**  1702890 Flat Washer - 1 1/4"

NOTE: Self-Tapping Screws - Use lock washers and nuts with self-tapping screws whenever possible. A minimum material thickness of 3/16" is required in order to use self-tapping screws without lock washers and nuts. Drill 13/32" holes if lock washers and nuts are used. Drill 5/16" holes if lock washers and nuts are not used.

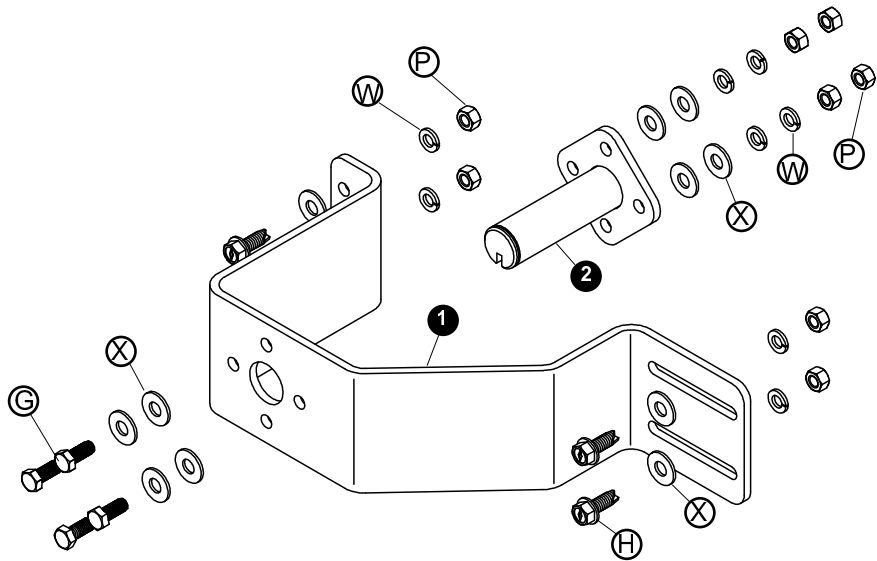

Item	Part #	Description
1.	1116919	Vertical Pivot Mount Bracket
2.	1116920	Pivot Pin - 4 Spring
G.	1702891	Cap Screw - 3/8" x 1 1/4"
H.	1700400	Self-Tapping Screw - 3/8" x 1"
P.	1700407	Hex Nut - 3/8"
W.	1700434	Lock Washer - 3/8"
X.	1700429	Flat Washer - 3/8"

STEP 1: Locate front pivot mount bracket on passenger side of trailer so that center of pivot lies within shaded area shown below. Measure 42" down from top of cap or 44" from top of windshield.

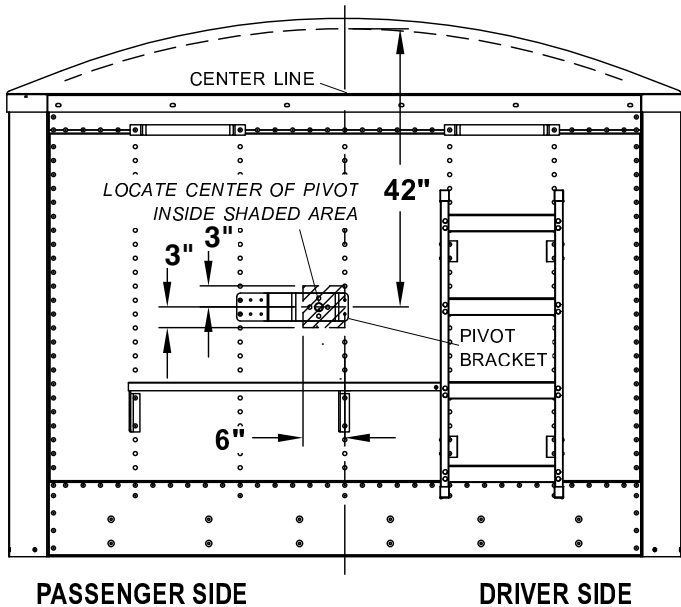

STEP 2: Hold pivot mount brackets in place. Using brackets as a guide, mark hole locations.

NOTE: Mount brackets into support braces on trailer if possible. Reinforce mounting area for adequate support if bracket cannot be mounted into support braces.

NOTE: Before drilling any holes, make sure flex arm has clear pathway to operate.

STEP 3: Remove rivets and mount brackets into rivet holes where possible. Otherwise, drill 5/16" holes in trailer. Fasten bracket to trailer with 3/8" self-tapping screws, flat washers, lock washers and nuts.

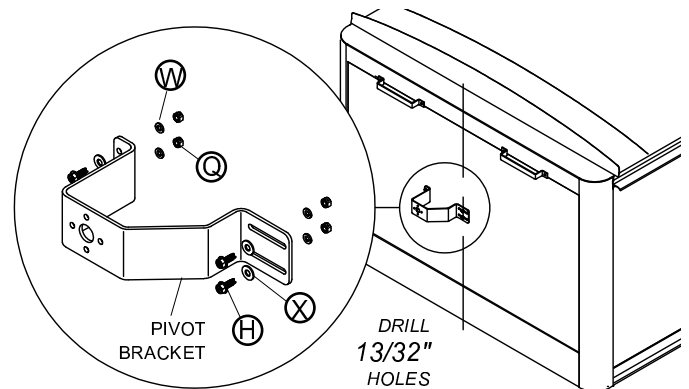

STEP 4: Fasten pivot pin to pivot bracket with 3/8" x 1 1/4" cap screws, flat washers, lock washers and nuts.

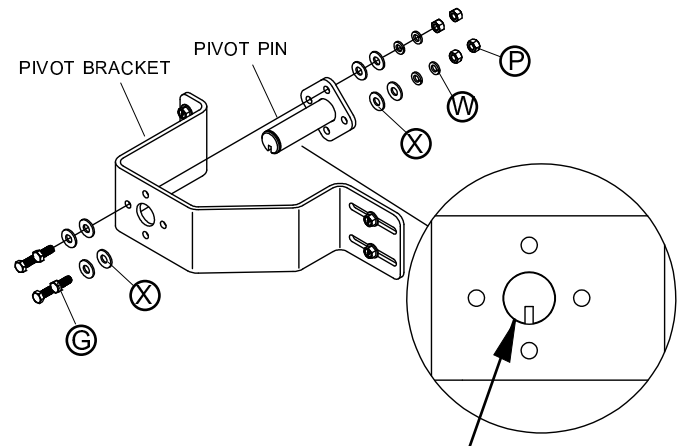

Slot in pivot pin must face downward.

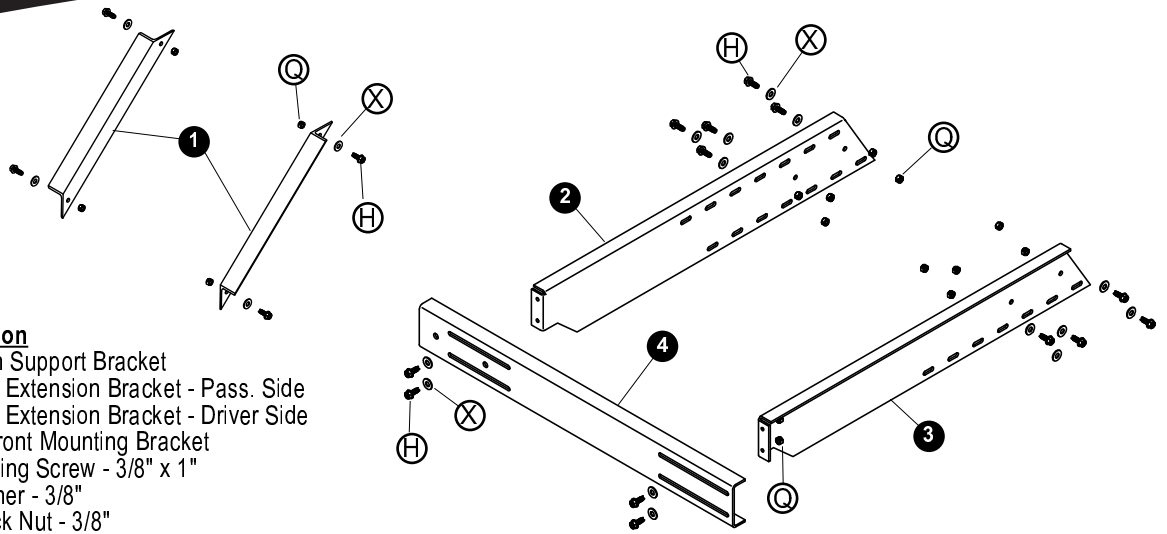

Item	Part #	Description
	1112310	Extension Support Bracket
2.	1113306	Universal Extension Bracket - Pass. Side
3.	1113307	Universal Extension Bracket - Driver Side
4.	1112178	Sloped Front Mounting Bracket
H.	1700400	Self-Tapping Screw - 3/8" x 1"
X.	1700429	Flat Washer - 3/8"
Q.	1700418	Centerlock Nut - 3/8"

STEP 1: Locate extension brackets 40" down from top of front cap. Mark line on box parallel to top rails on front and outer sides of cylinder box.

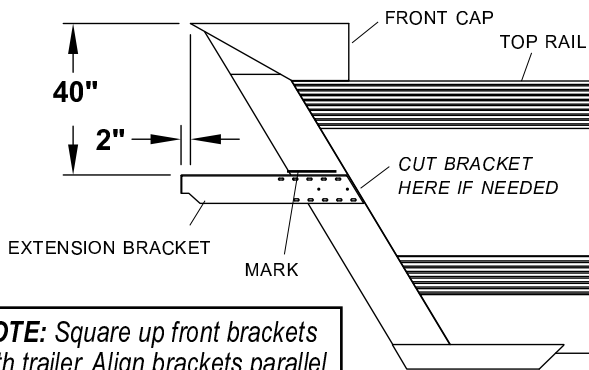

NOTE: Square up front brackets with trailer. Align brackets parallel to top rails.

STEP 2: Align front edge of extension bracket 2" past farthest point of front cap. Cut back end of bracket to fit.

STEP 3: Using bracket as guide, mark and drill 5/16" holes at two slots and fasten bracket to cylinder box with 3/8" x 1" self-tapping screws and flat washers.

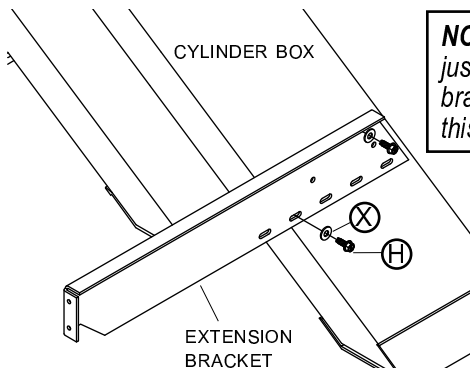

NOTE: Tighten bolts just enough to hold bracket in place at this time.

STEP 4: Align center of sloped front mounting bracket with center of trailer. Fasten sloped front bracket to extension brackets with 3/8" x 1" self-tapping screws, flat washers and centerlock nuts.

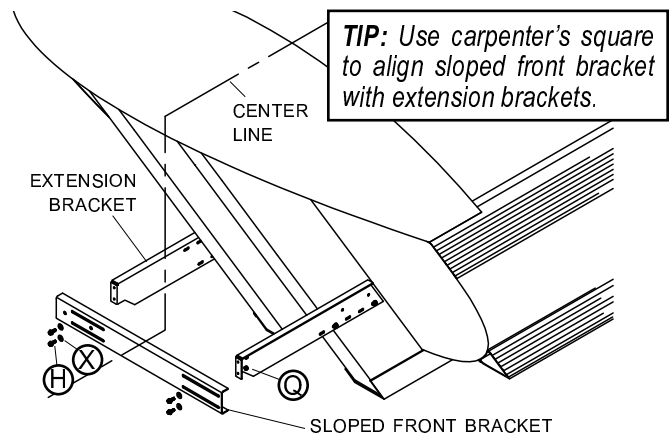

STEP 5: Fasten support brackets to extension brackets and cylinder box with 3/8" x 1" self-tapping screws, flat washers and centerlock nuts.

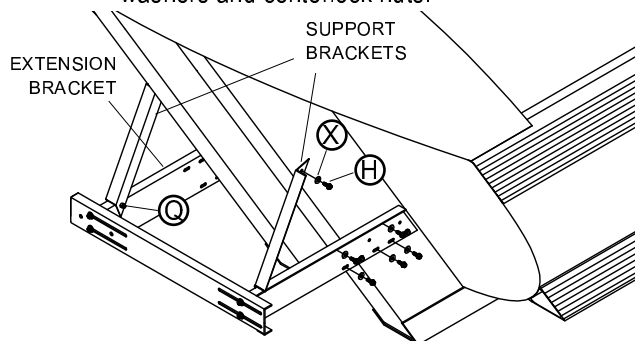

STEP 6: Drill 5/16" holes into cylinder box at remaining slots in extension brackets. Fasten with 3/8" x 1" self-tapping screws and flat washers. Square up brackets with front of trailer. Tighten all bolts.

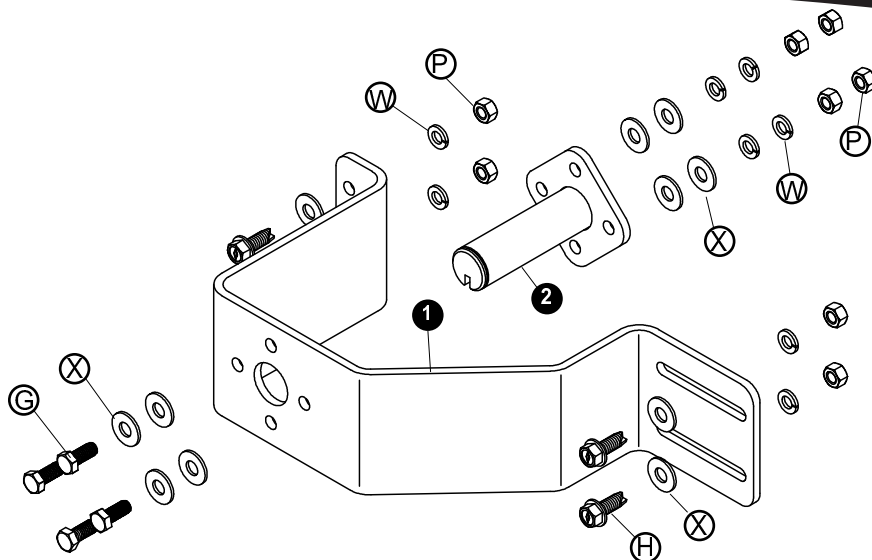

Item	Part #	Description
1.	1116919	Vertical Pivot Mount Bracket
2.	1116920	Pivot Pin - 4 Spring
G.	1702891	Cap Screw - 3/8" x 1 1/4"
H.	1700400	Self-Tapping Screw - 3/8" x 1"
P.	1700407	Hex Nut - 3/8"
W.	1700434	Lock Washer - 3/8"
X.	1700429	Flat Washer - 3/8"

STEP 1: Locate front pivot mount bracket so center of pivot lies on passenger side of center line, within shaded area shown below.

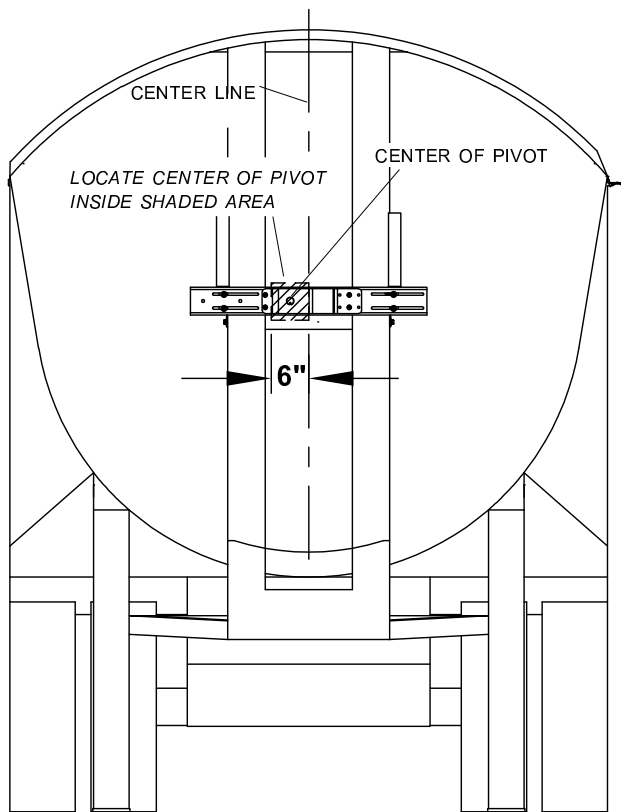

STEP 2: Hold pivot mount brackets in place. Using brackets as guide, mark hole locations.

NOTE: Before drilling any holes make sure flex arm has a clear pathway to operate.

STEP 3: Mark and drill 5/16" holes. Fasten pivot bracket to mounting bracket with 3/8" x 1" self-tapping screws, flat washers, lock washers and nuts.

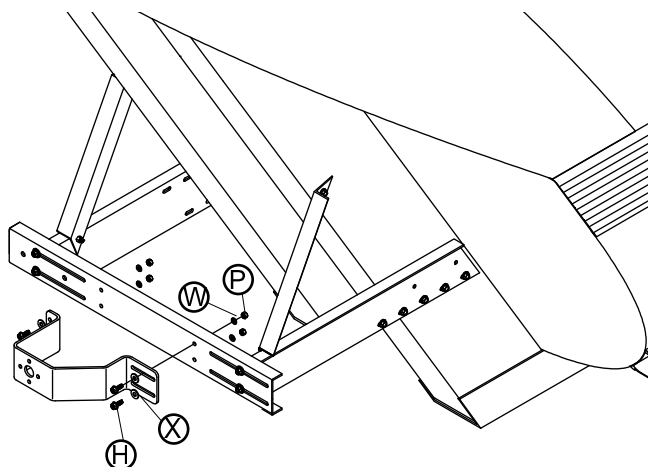

STEP 4: Fasten pivot pin to pivot bracket with 3/8" x 1 1/4" cap screws, flat washers, lock washers and nuts.

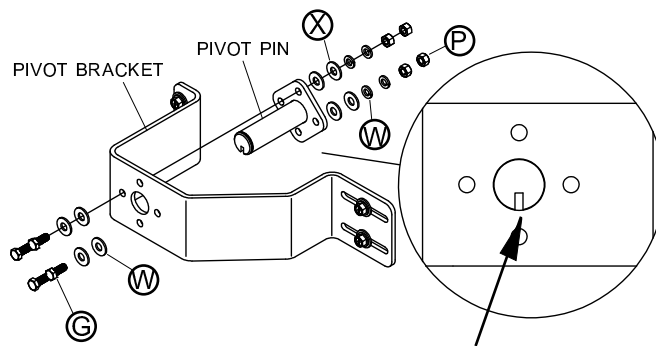

Slot in pivot pin must face downward

Item	Part #	Description
1.	1116919	Vertical Pivot Mount Bracket
2.	1116920	Pivot Pin - 4 Spring
3.	1116994	Pivot Mount Bracket - Sloped
G.	1702891	Cap Screw - 3/8" x 1 1/4"
H.	1700400	Self-Tapping Screw - 3/8" x 1"
P.	1700407	Hex Nut - 3/8"
W.	1700434	Lock Washer - 3/8"
X.	1700429	Flat Washer - 3/8"

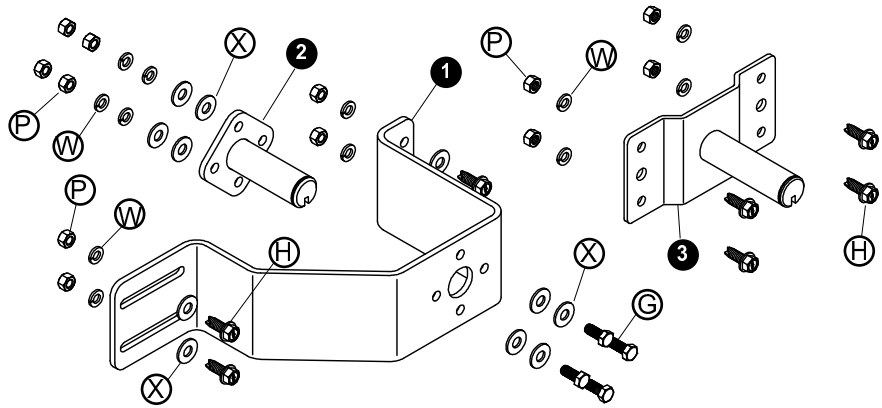

NOTE: Rear pivot mount bracket may be located anywhere on rear of trailer as long as upper flex arm is parallel with side of trailer when tarp is closed and rolled up under latchplate.

STEP 1: To determine rear pivot mount bracket location, align bearing hole in upper flex arm with roll tube under latchplate. Hold upper flex arm parallel to side of trailer and lift lower flex arm up so center of pivot is 39" to 45" below top of rear cap.

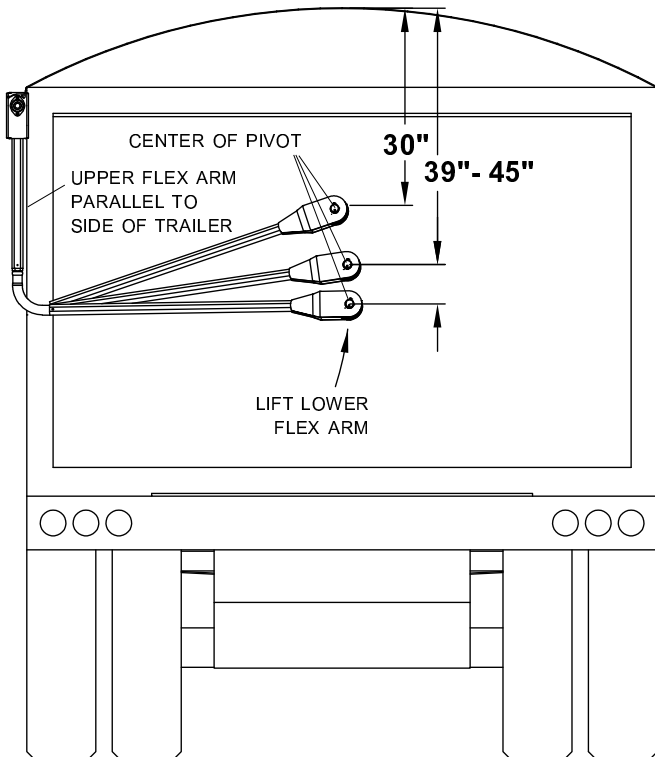

NOTE: If pivot pin cannot be located in recommended area because of grain doors, pivot arm may be located between 30" and 45" below top of cap.

STEP 2: Mark and drill 5/16" holes in trailer. Fasten bracket to trailer with 3/8" self-tapping screws, lock washers and nuts.

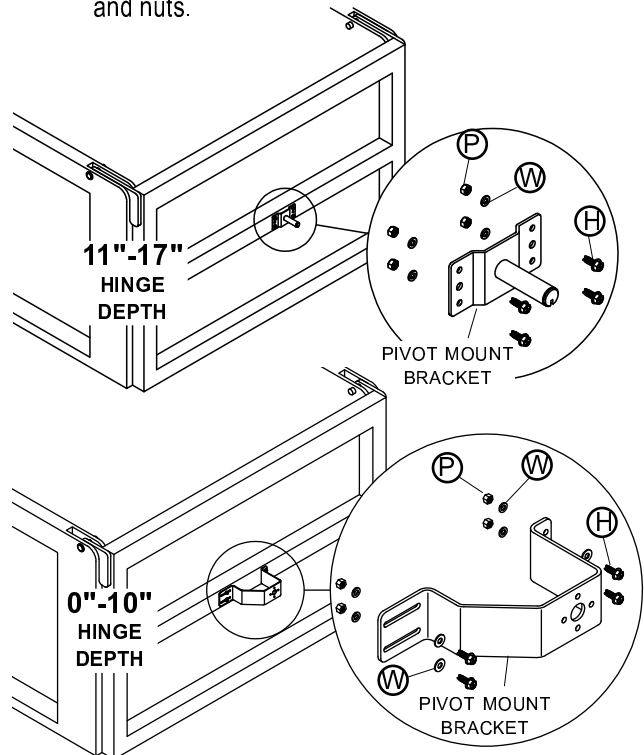

STEP 3: 0"-10" hinge depth. Fasten pivot pin to bracket with 3/8" x 1 1/4" cap screws, flat washers, lock washers and nuts.

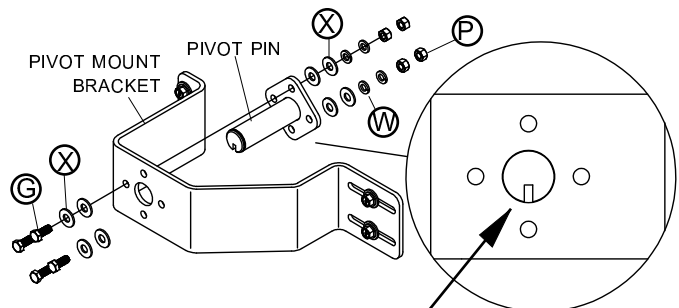

Slot in pivot pin must face downward

Item	Part #	Description
1.	1703135	Heavy-Duty Motor
2.	1110408	Flange Bearing
3.	1118015	Upper Flex Arm - Motor Side
4.	1116924	Manual Override Collar
5.	1112954	Roll Tube Extension w/Drive Shaft - 7.313"
6.	1111027	Spiral Torsion Spring
7.	1703882	Cap Plug w/Hole - 1 1/4"
8.	1703873	Flex Arm Joint
9.	1116905	Lower Flex Arm
10.	1702888	Retaining Ring - 1 1/4"
11.	1703822	Dual-Conductor Wire 6 Ga. 259 Strand
12.	1117033	Spacer Tube - .35" x 2 5/8"

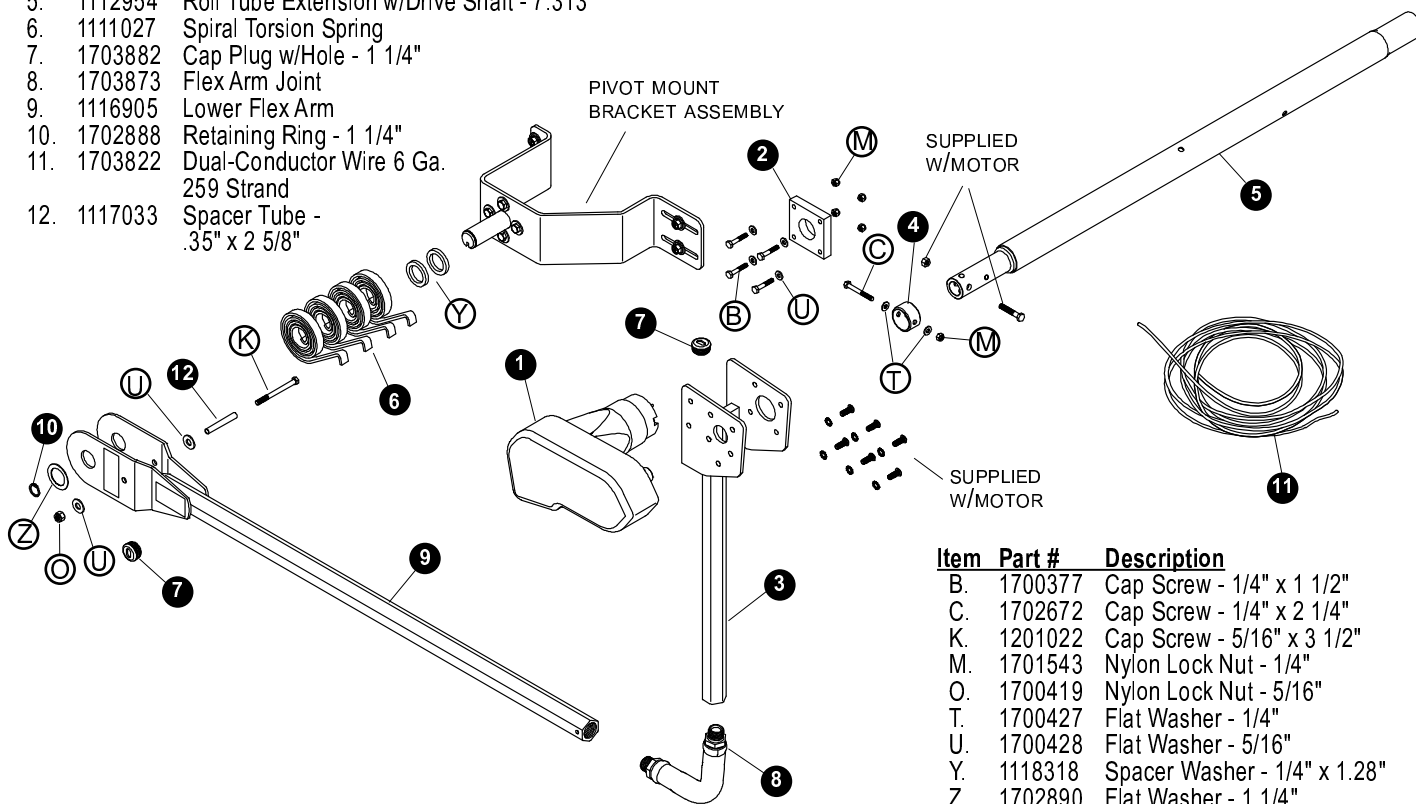

Item	Part #	Description
B.	1700377	Cap Screw - 1/4" x 1 1/2"
C.	1702672	Cap Screw - 1/4" x 2 1/4"
K.	1201022	Cap Screw - 5/16" x 3 1/2"
M.	1701543	Nylon Lock Nut - 1/4"
O.	1700419	Nylon Lock Nut - 5/16"
T.	1700427	Flat Washer - 1/4"
U.	1700428	Flat Washer - 5/16"
Y.	1118318	Spacer Washer - 1/4" x 1.28"
Z.	1702890	Flat Washer - 1 1/4"

STEP 1: Install cap plug with hole on lower flex arm. Fasten spacer tube into spring support bracket on lower flex arm with 5/16" x 3 1/2" cap screw, two flat washers and lock nut.

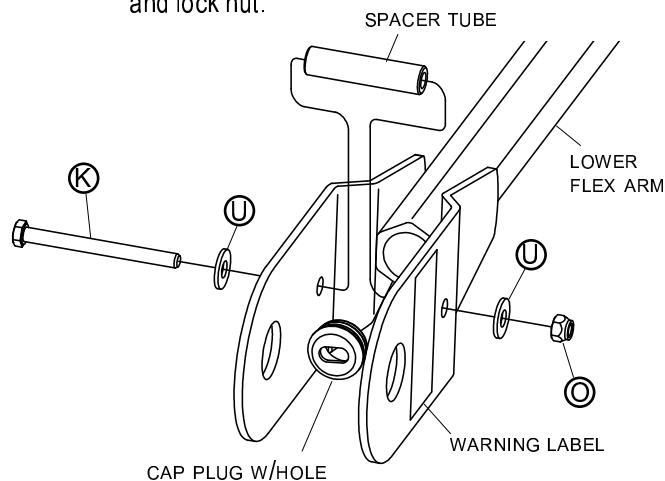

NOTE: Insert cap screw through flex arm so head of screw will be on inside of assembly (toward trailer). Warning label must be in plain view on outside of assembly.

STEP 2: Assemble spacer washers on pivot pin.

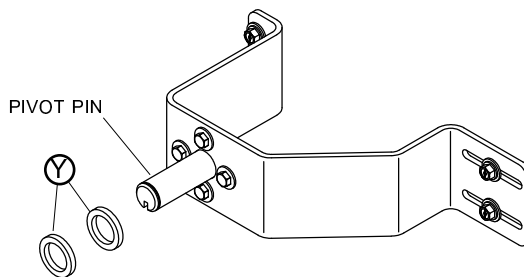

STEP 3: Assemble spiral torsion springs and lower flex arm on pivot pin. Hook springs over spacer tube.

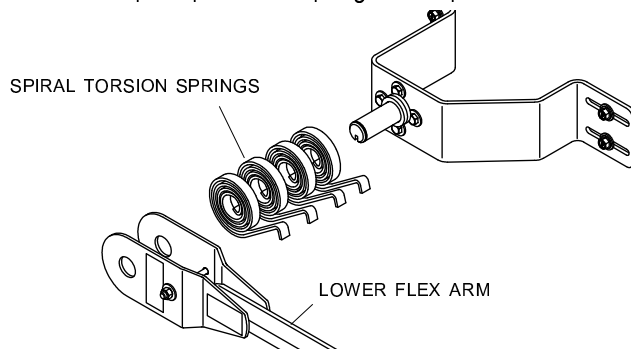

STEP 4: Secure with 1 1/4" flat washer and retaining ring.

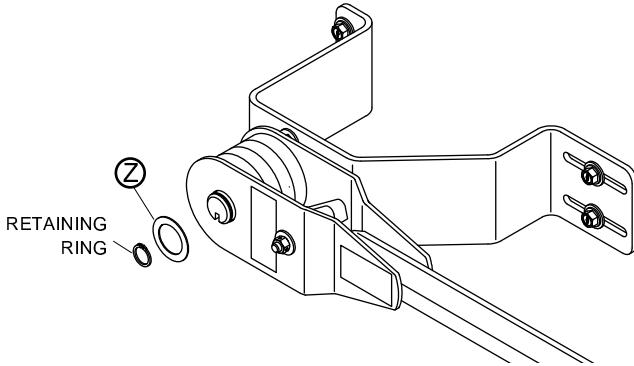

STEP 5: Insert wire (black with red stripe) through lower flex arm and flex arm joint. Thread flex arm joint into lower flex arm. Hand tighten only.

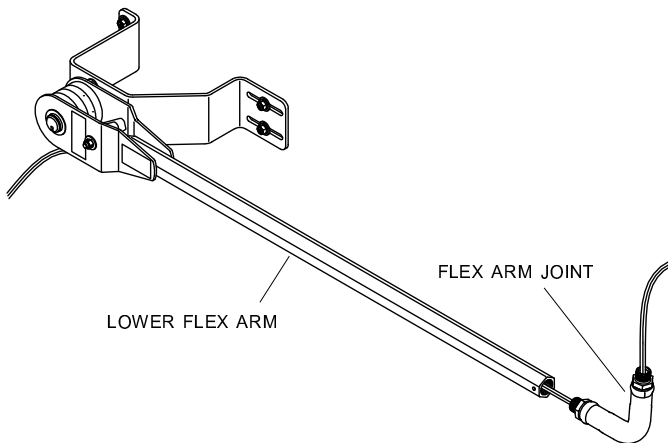

STEP 6: Insert wire through upper flex arm, then thread upper flex arm onto flex arm joint. Hand tighten only.

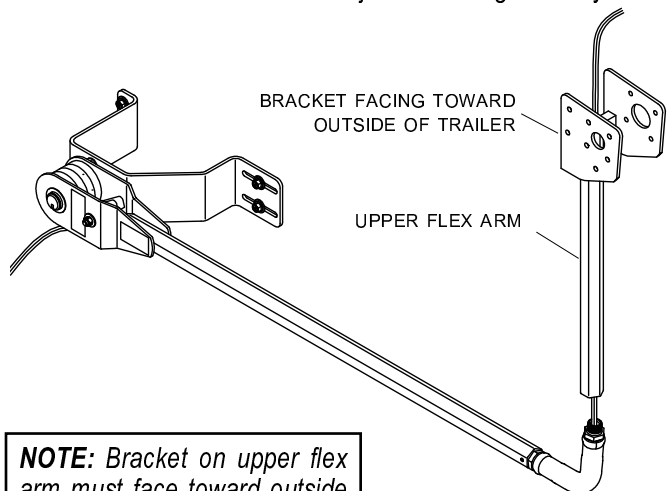

NOTE: Bracket on upper flex arm must face toward outside of trailer as shown above.

STEP 7: Install cap plug with hole on upper flex arm. Leave about 12" of wire extending out of flex arm.

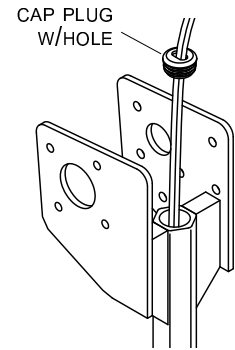

STEP 8: Mount electric motor to upper flex arm with 5/16" button head cap screws and star washers.

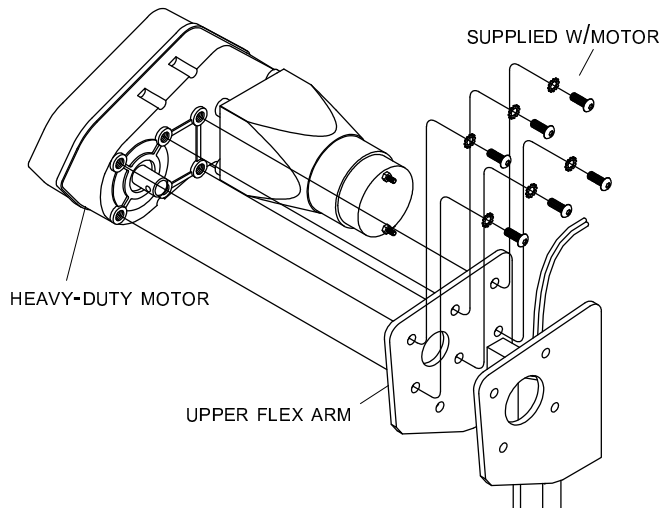

ATTENTION:

- Use all mounting bolts when mounting gear motor.
- Do not use power tools.
- Do not overtighten (torque 5/16" x 7/8" Button Hd. Bolts to 70 in/lbs).
- Over tightening may crack case.
- Install star washers on bolt side of mounting plate.
- Do not use any form of thread locker.

STEP 9: Mount bearing flange to upper flex arm bracket with 1/4" x 1 1/2" cap screws, washers and lock nuts. **Finger tighten only to allow for adjustment.**

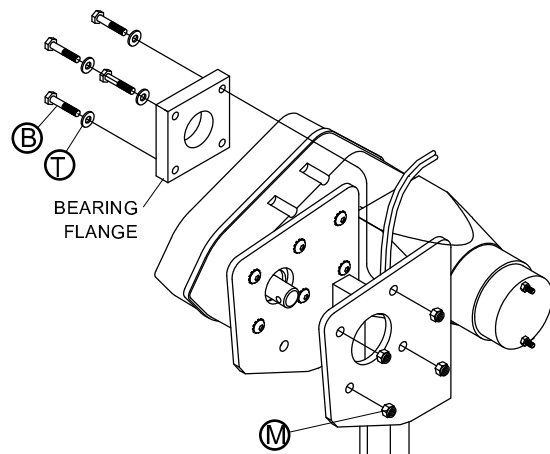

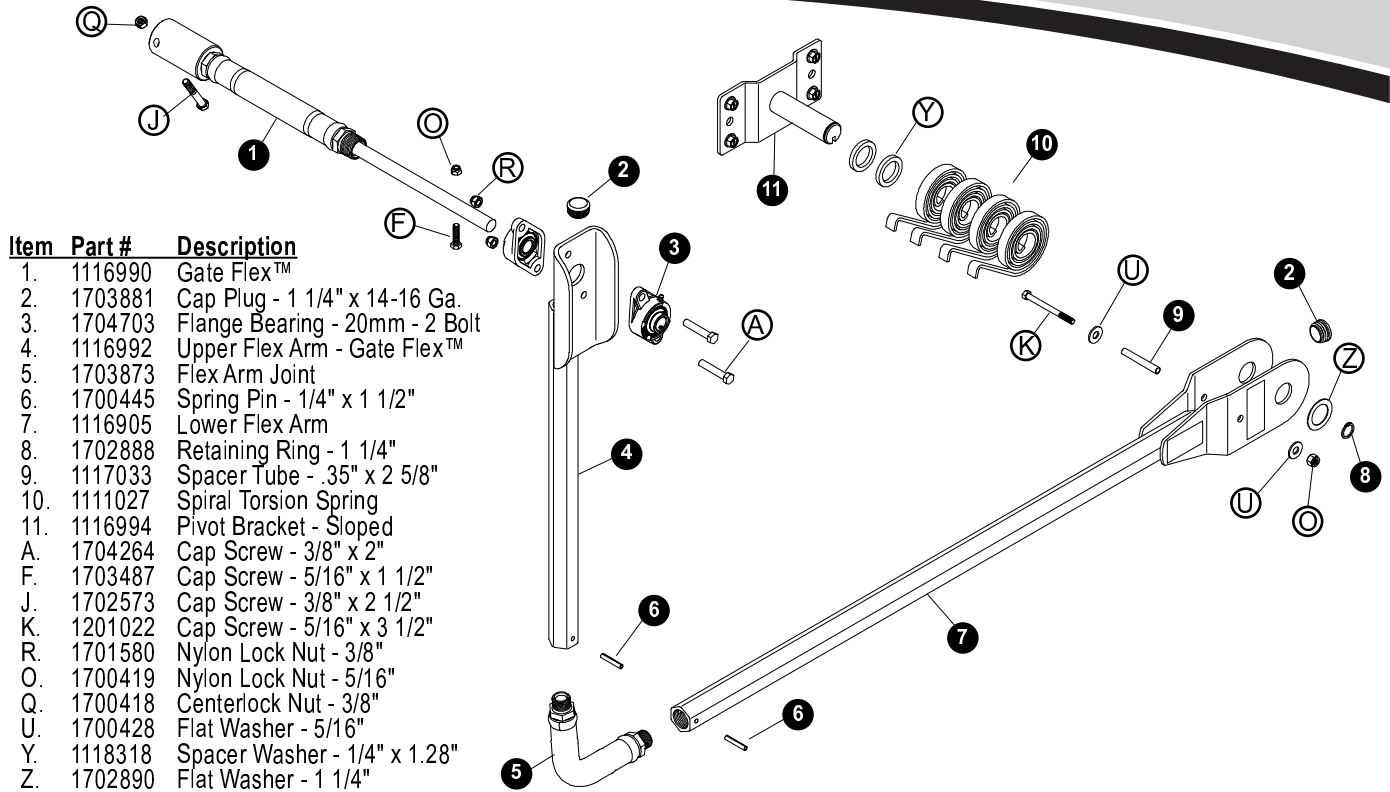

STEP 1: Install cap plug on lower flex arm. Fasten spacer tube into spring support bracket on lower flex arm with 5/16" x 3 1/2" cap screw, two flat washers and lock nut.

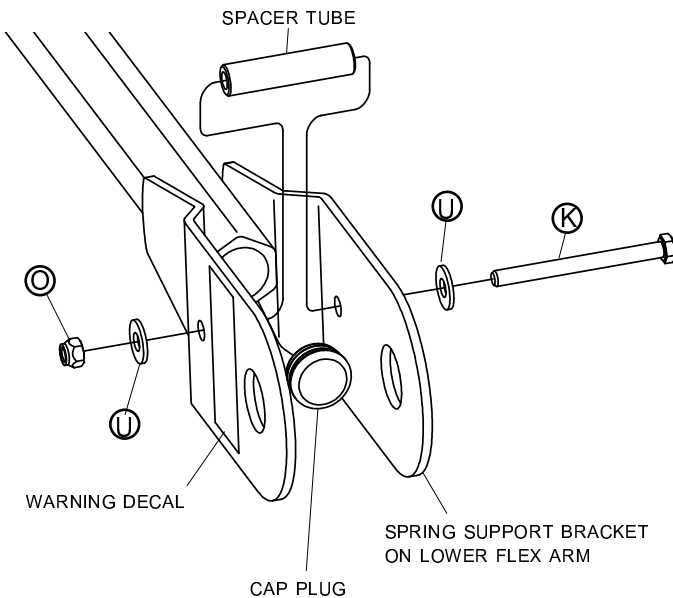

STEP 2: Assemble spacer washers on pivot pin.

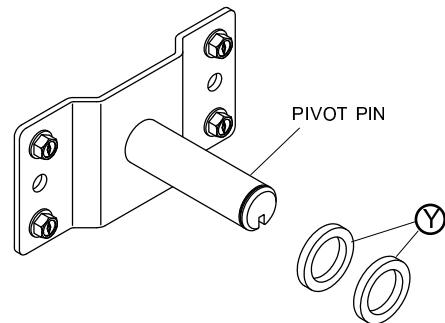

STEP 3: Assemble spiral torsion springs and lower flex arm on pivot pin. Hook springs over spacer tube.

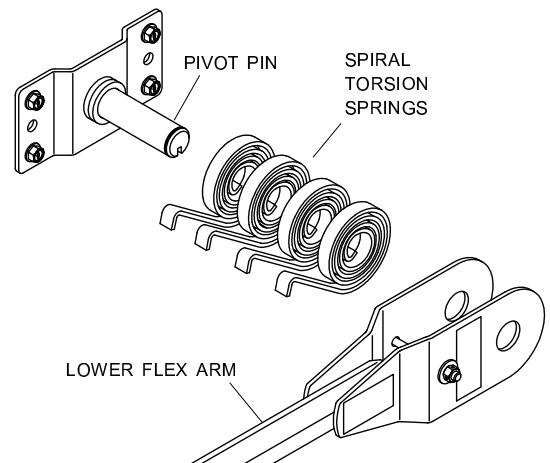

NOTE: Insert cap screw through flex arm so head of screw will be on inside of assembly (toward trailer). Warning label must be in plain view on outside of assembly.

STEP 4: Secure with 1 1/4" flat washer and retaining ring.

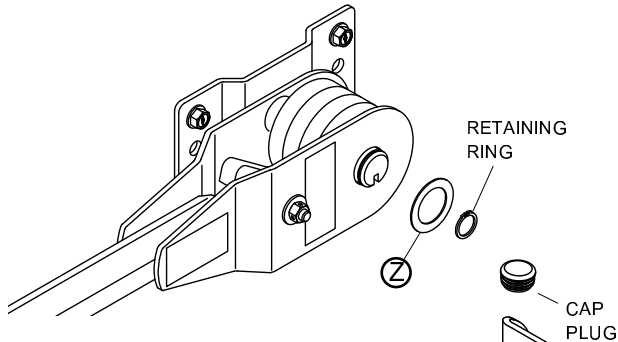

STEP 5: Install cap plug on upper flex arm.

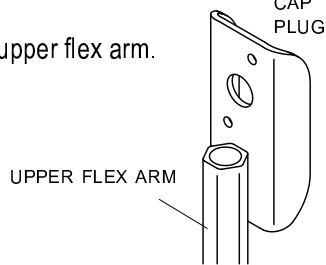

STEP 6: Fasten flange bearings to bearing mount plate with 3/8" x 2" cap screws and lock nuts as shown.

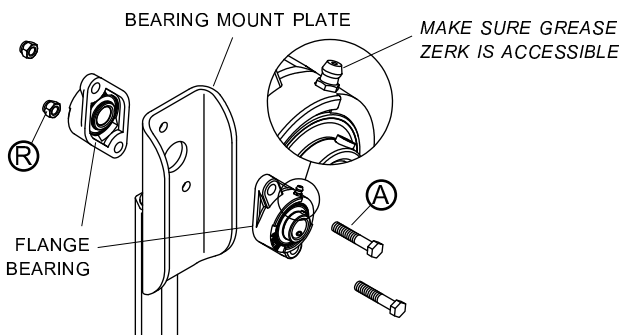

STEP 7: Thread flex arm joint into lower flex arm, then into upper flex arm. Tighten threads, aligning bearing mount plate on upper flex arm parallel to spring support bracket on lower flex arm as shown.

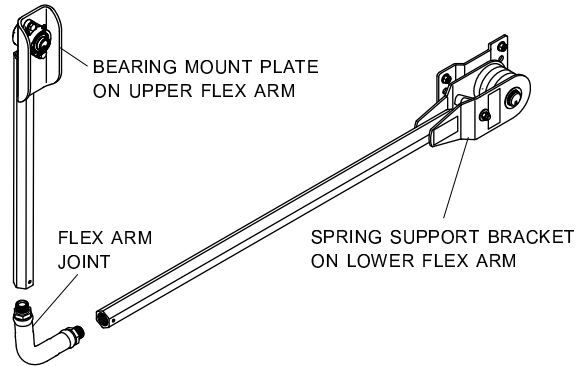

STEP 8: Drill 1/4" holes through flex arm joint assembly at pre-drilled holes in upper and lower flex arm. Install 1/4" x 1 1/2" spring pins into holes.

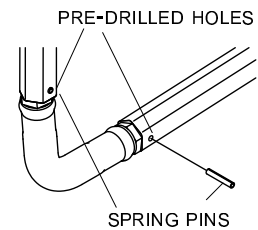

STEP 9: Roll tarp closed over box with roll tube hanging below latchplate. Remove crank assembly and U-clamps from roll tube.

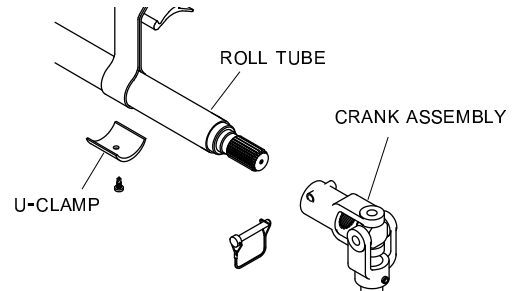

Roll Tube Extension Installation

STEP 1: Rear of Trailer. Adjust roll tube forward or backward to align end of splined shaft with gate hinge pin.

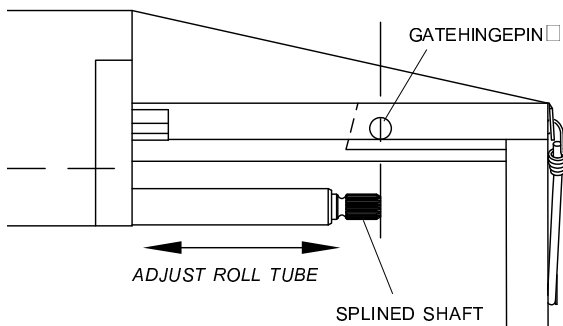

NOTE: If hinge depth is 0" to 4", set end of splined shaft 4" in from back of gate.

STEP 2: Slide Gate Flex™ completely over splined shaft on roll tube. Fasten with 3/8" x 2 1/2" cap screw and centerlock nut.

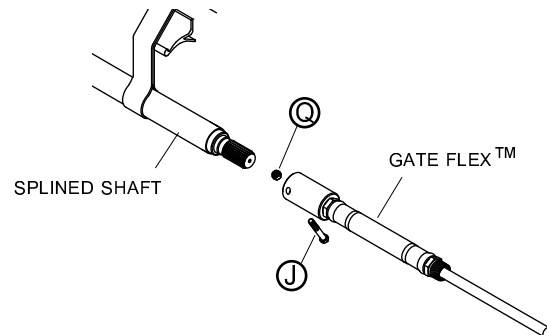

NOTE: Do not remove splined shaft. Splined shaft will be used if system is switched to manual operation.

STEP 3: Slide bearing shaft on Gate Flex™ through flange bearing on upper flex arm. Drill 5/16" hole through bearing shaft. Insert 5/16" x 1 1/2" cap screw through hole and secure with lock nut.

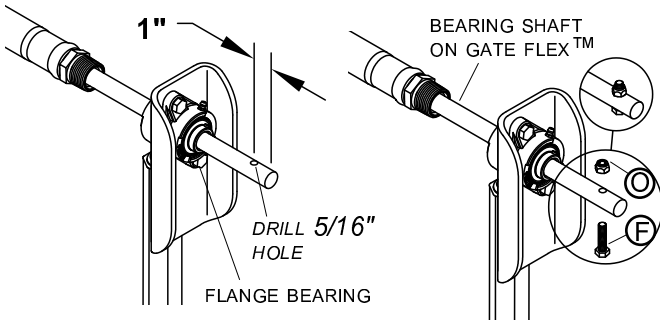

NOTE: Do not leave unattended until flex arm is securely fastened to roll tube extension as shown.



WARNING

Flex arms are under tension while torsion springs are engaged. Use caution while assembling and disassembling arms. Failure to read and follow instructions could result in serious injury or death.

STEP 4: On vertical trailers, align upper flex arm in a vertical plane 90° to roll tube. On sloped trailers, align upper flex arm parallel to back of trailer. Tighten set screws in flush mount bearing.

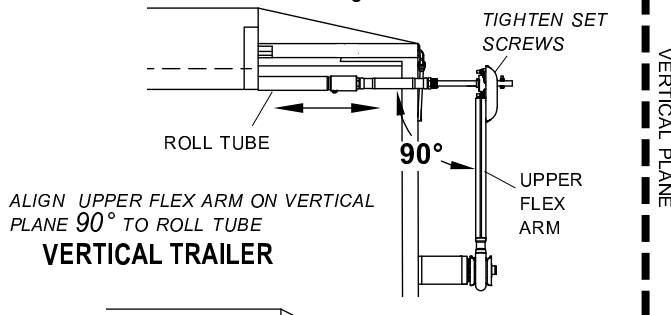

ALIGN UPPER FLEX ARM ON VERTICAL PLANE 90° TO ROLL TUBE
VERTICAL TRAILER

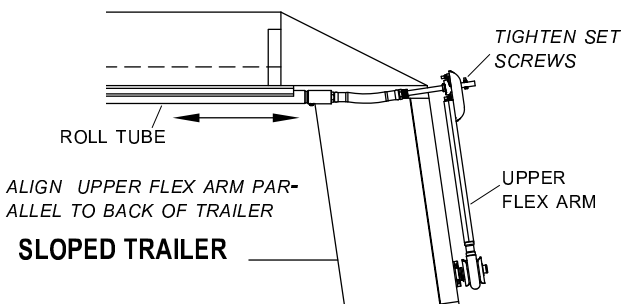

ALIGN UPPER FLEX ARM PARALLEL TO BACK OF TRAILER
SLOPED TRAILER

STEP 5: Front of Trailer: Slide tarp back on roll tube.

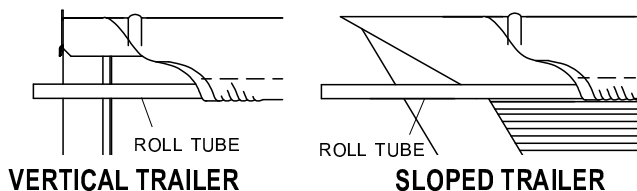

STEP 6: Insert motor shaft into roll tube extension with drive shaft. Fasten with 3/8" cap screw and top lock nut supplied with motor. Finger tighten only.

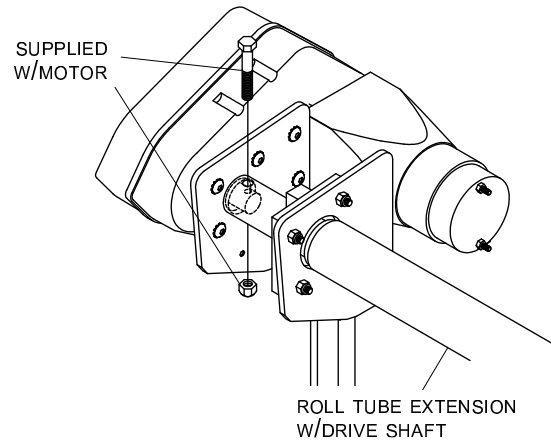

STEP 7: Hold flex arm with motor and roll tube extension in vertical plane to trailer and 90° to roll tube. Mark roll tube at location to be cut as shown.

NOTE: Two people required for safe installation.

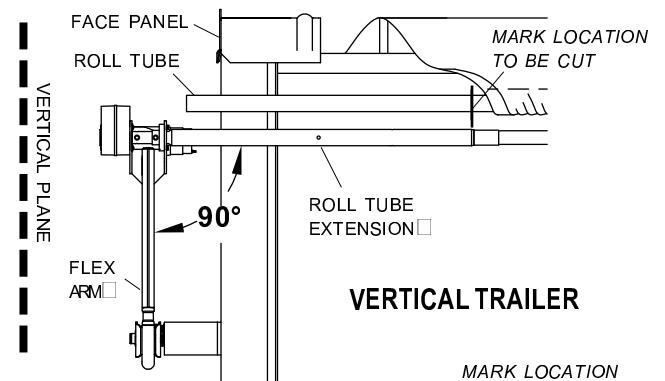

VERTICAL TRAILER

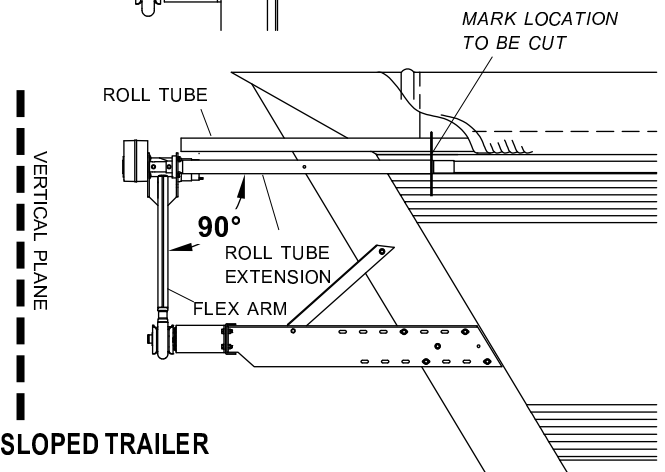

SLOPED TRAILER

STEP 8: Unfasten and remove motor from roll tube extension. Remove roll tube extension from roll tube. Cut roll tube at marked location.

STEP 9: Mark and drill 3/8" holes through roll tube at right angles to each other in locations shown.

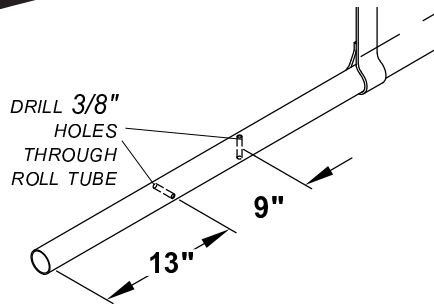

STEP 10: Insert swaged end of roll tube extension w/drive shaft into roll tube. Align extension straight with roll tube and align holes. Weld as shown and grind smooth.

NOTE: Pull roll tube away from tarp and trailer before welding to protect from weld spatter. Align roll tube extension straight with roll tube before welding so tarping system will roll smoothly.

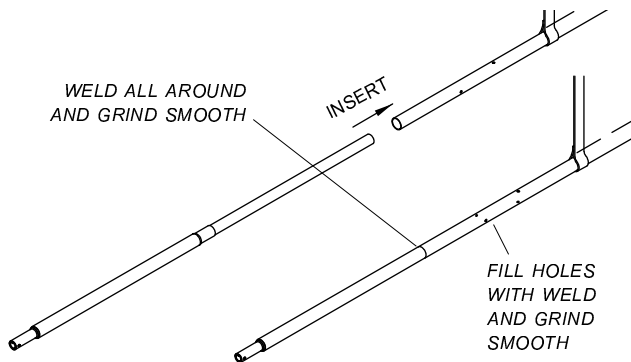

NOTE: To prevent rust, paint all weld seams and/or metal exposed by grinding or cutting with corrosion-resistant paint.

STEP 11: Slide roll tube/roll tube extension weldment back into position and align upper flex arm on front of trailer. Follow steps 6 to 7 to install motor, positioning motor as shown below. Make sure torsion springs load when tarp opens.

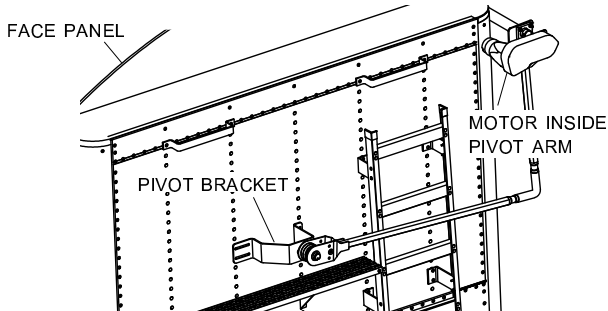

WARNING

Flex arms are under tension while torsion springs are engaged. Use caution while assembling and disassembling arms. Failure to read and follow instructions could result in serious injury or death.

STEP 12: Remove cap screw from motor shaft. Hang manual override collar over electric motor shaft.

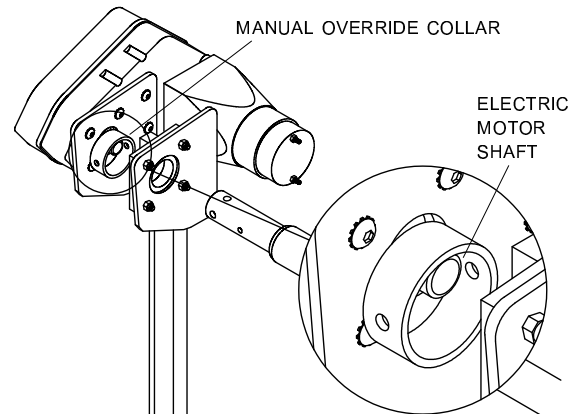

STEP 13: Insert roll tube extension through upper flex arm bracket and manual override collar. Secure roll tube to electric motor shaft with 3/8" x 2 1/4" cap screw and top lock nut (supplied with motor). Tighten all fasteners securely.

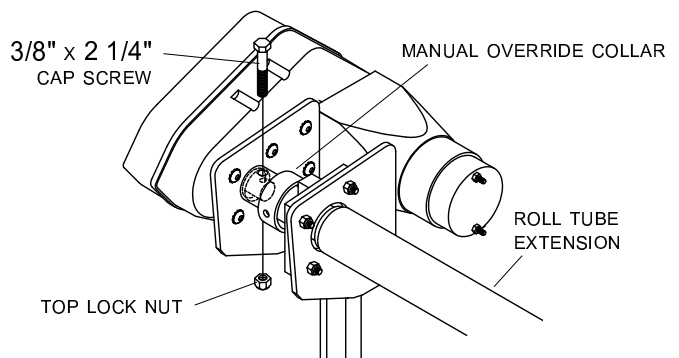

STEP 14: Fasten manual override collar to roll tube with 1/4" x 2 1/4" cap screw, two flat washers and lock nut.

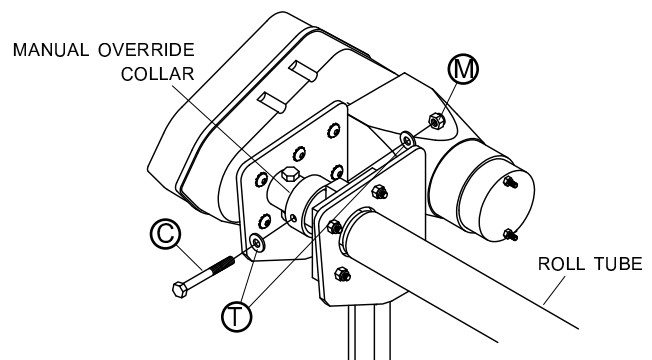

NOTE: Verify again, flex arm is on vertical plane and is parallel to face panel before proceeding. Make sure all fasteners holding motor to upper flex arm bracket are tightened securely.

STEP 15: Re-fasten tarp to roll tube with existing U-clamps and screws. Tighten all fasteners securely. Tighten front and rear flex arm connections.

Item	Part #	Description
1.	1703661	Mounting Bracket - Rocker Switch
2.	1116020	Rocker Switch
3.	1703845	Motor Reversing Solenoid
4.	1109015	Mounting Bracket
5.	1115385	Heavy-Duty Dual Conductor Plug
6.	1115386	Heavy-Duty Dual Conductor Socket
7.	1704354	40-Amp Modified-Reset Circuit Breaker
8.	1704573	Conductor Socket Sealed Boot
9.	1703896	Solenoid Cover
10.	1703245	Ring Terminal - 6 Ga. x #10 Stud
11.	1703244	Ring Terminal - 6 Ga. x 3/8"
12.	1704153	Ring Terminal - 14 Ga. x 1/4" Stud
13.	1703659	Push On Terminal - 14 Ga. x 1/4"
14.	1702707	Ring Terminal - 6 Ga. 1/4 Stud
D.	1701045	Cap Screw - 5/16" x 3/4"
H.	1700400	Self-Tapping Screw - 3/8" x 1"
N.	1700411	Hex Nut - 5/16"
P.	1700407	Hex Nut - 3/8"
W.	1700434	Lock Washer - 3/8"

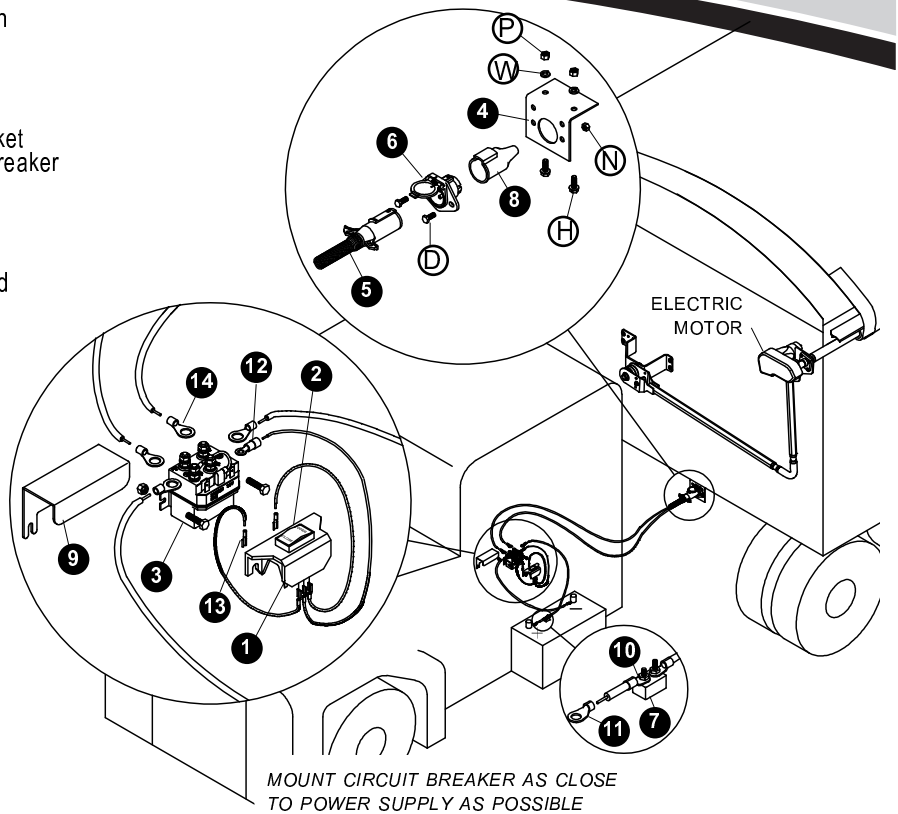

Cut wires to length and strip only enough wire insulation to install ring terminals. Insert bare wire into ring terminals and crimp securely.

STEP 1: Circuit breaker & battery. Mount circuit breaker as close as possible to battery or power supply.

STEP 2: Mount solenoid. Mount solenoid in suitable location - a ventilated area near battery is ideal. Determine best route for wire. This is usually along frame with existing wire harness. Run 6-ga. wire from conductor plug to solenoid and from power supply to solenoid as shown in diagram. Run 14-ga. wires from solenoid to switch.

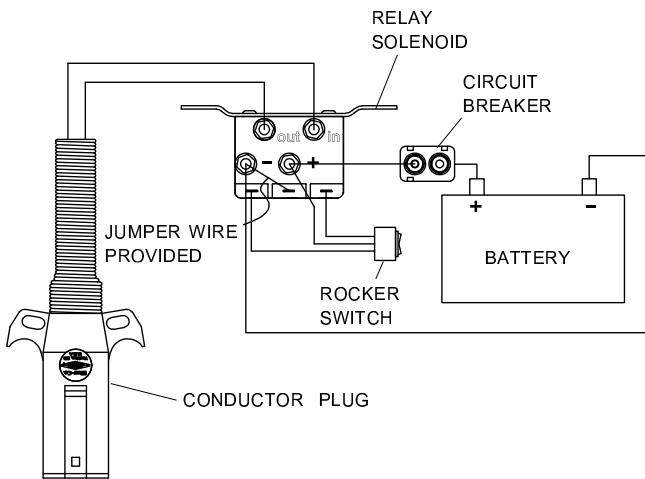

STEP 3: Rocker switch. Locate rocker switch in convenient operating location. Switch can be mounted in cab, on dash panel, on driver side door jamb or in convenient location outside cab.

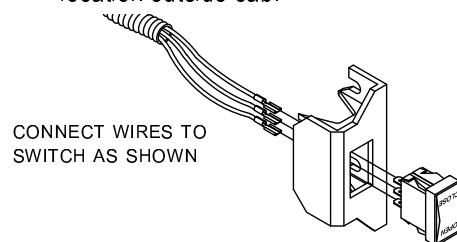

STEP 4: Conductor plug. Unfasten and remove insert from conductor plug. Feed 6-ga. wire through plug and into brass contacts on insert. Tighten set screws to secure wires. Replace insert into conductor plug and secure screw.

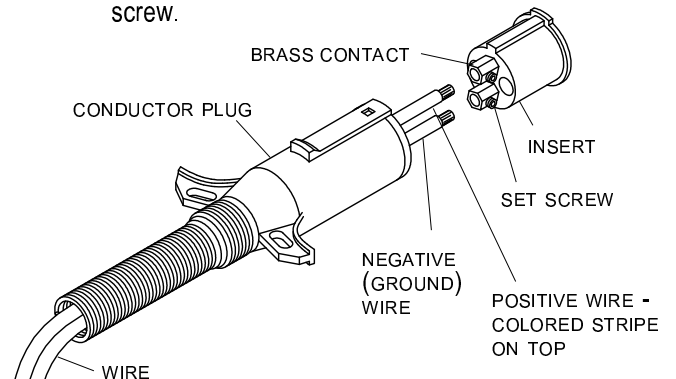

STEP 1: Mounting bracket. Mount bracket at suitable location on front of trailer, usually near existing plugs. Mark and drill 5/16" holes and fasten with 3/8" x 1" self-tapping screws, lock washers and nuts.

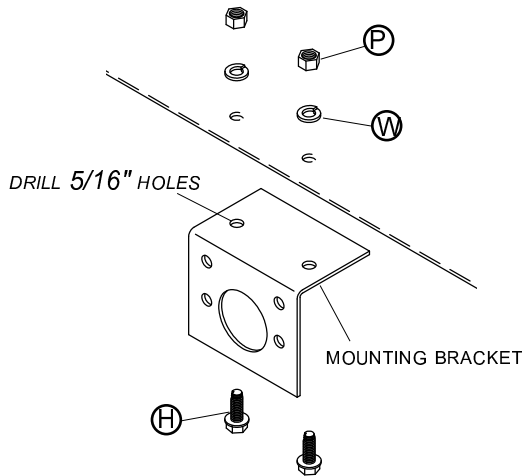

STEP 2: Conductor socket. Fasten conductor socket to mounting bracket with 5/16" x 3/4" cap screws and lock nuts.

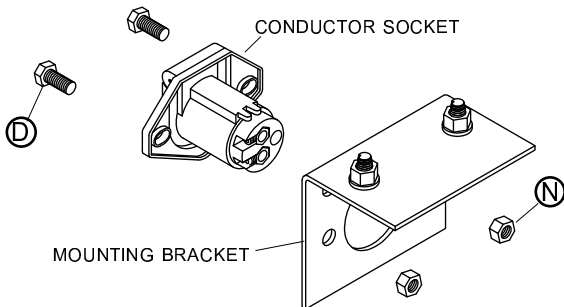

Bring 6-ga. wire from lower end of pivot arm through sealed boot. Connect wire ends to conductor socket, aligning positive wire on socket with positive wire on conductor plug. Slide sealed boot against conductor socket and secure boot to wire with cable tie.

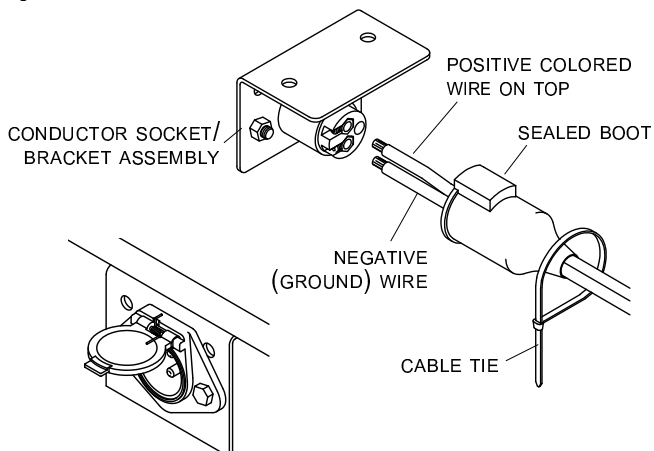

STEP 3: Connect wires at top of pivot arm to motor.

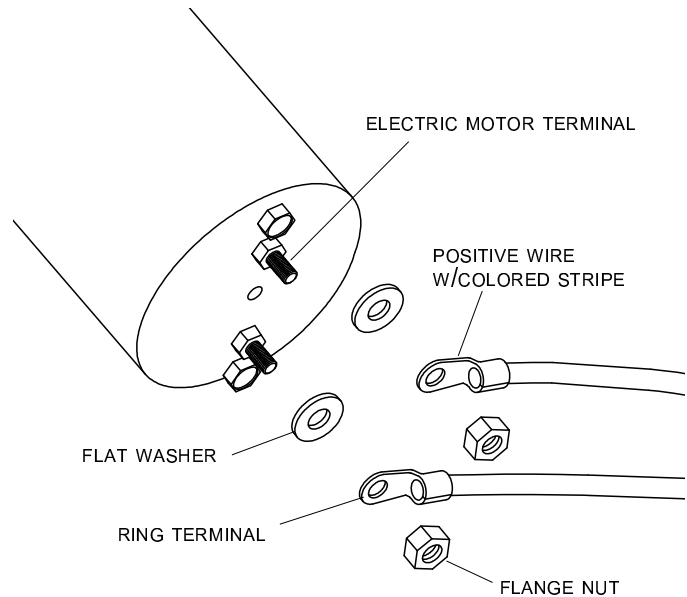

⚠ CAUTION
 Check all hardware for complete assembly before operating. Inspect system at this time and adjust as required.

OPERATION:

A) Check motor direction by activating switch to "OPEN". If switch is running system backwards, change wire leads on motor to opposite connections.

B) Close tarp: Push switch to "CLOSE" and hold. Observe tarp and release switch when tarp is fully closed.

C) Open tarp: Push switch to "OPEN" and hold. Observe tarp and release switch when tarp is fully open.

NOTE: Release switch at end of cycle or modified-reset circuit breaker will trip. After breaker resets, switch will activate motor again. To reduce unnecessary strain on tarp components, release switch at end of each cycle.

Item	Part #	Description
1.	1118257	Shur-Co® Wireless Receiver
2.	1109015	Mounting Bracket
3.	1115385	Heavy-Duty Dual Conductor Plug
4.	1115386	Heavy-Duty Dual Conductor Socket
5.	1704354	40-Amp Modified-Reset Circuit Breaker
6.	1702707	Ring Terminal - 6 Ga. 1/4" Stud
7.	1704330	Rubber Insulating Boot
8.	1704573	Conductor Socket Sealed Boot
D.	1701045	Cap Screw - 5/16" x 3/4"
E.	1701059	Self-Tapping Screw - 5/16" x 1"
H.	1700400	Self-Tapping Screw - 3/8" x 1"
N.	1700411	Hex Nut - 5/16"
O.	1700419	Lock Nut - 5/16"
P.	1700407	Hex Nut - 3/8"
V.	1700428	Flat Washer - 5/16"
W.	1700434	Lock Washer - 3/8"

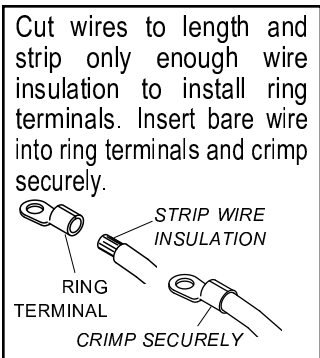
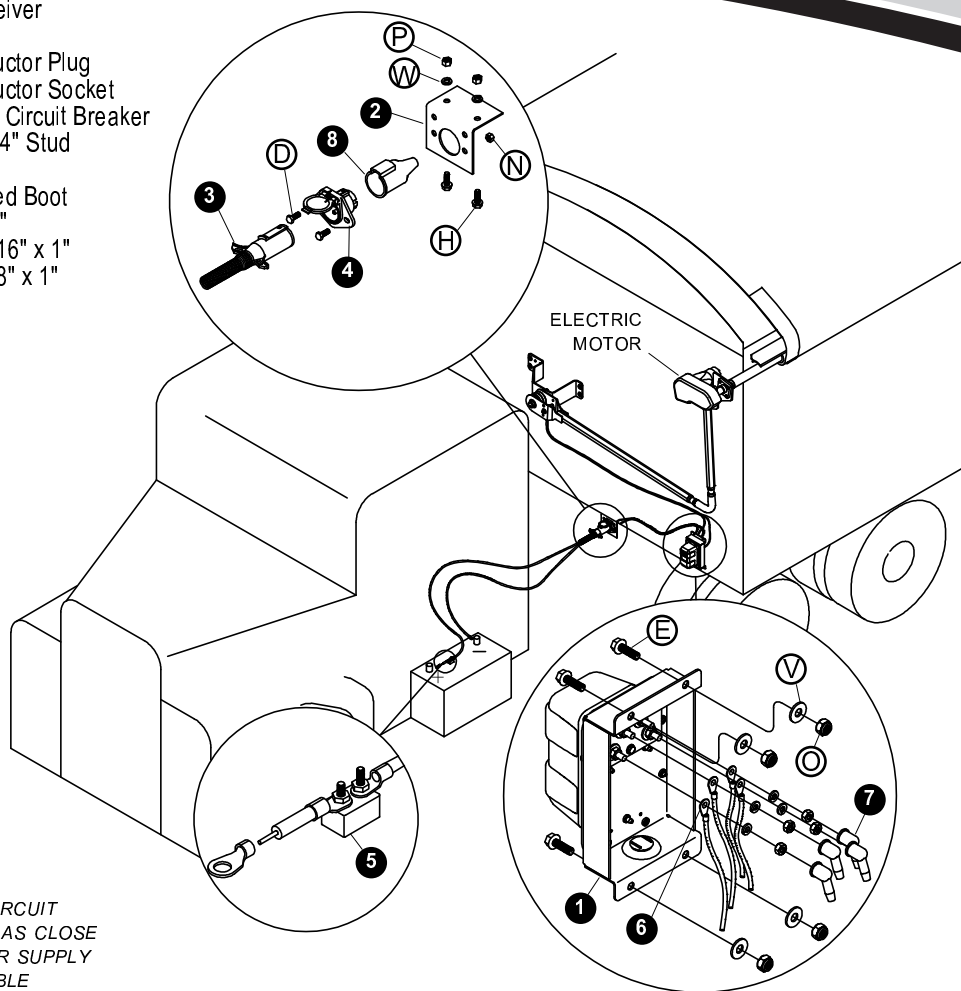

MOUNT CIRCUIT BREAKER AS CLOSE TO POWER SUPPLY AS POSSIBLE

STEP 1: Circuit breaker & battery. Mount circuit breaker as close as possible to battery or power supply.

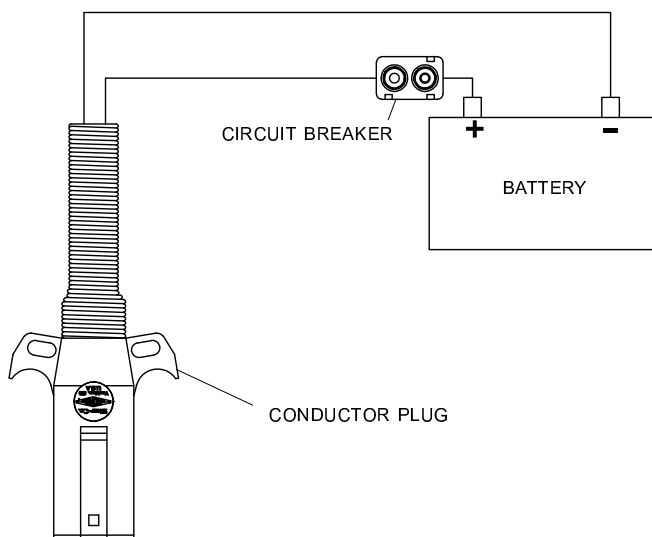

STEP 2: Conductor plug. Unfasten and remove insert from conductor plug. Feed 6-ga. wire through plug and into brass contacts on insert. Tighten set screws to secure wires. Replace insert into conductor plug and secure screw.

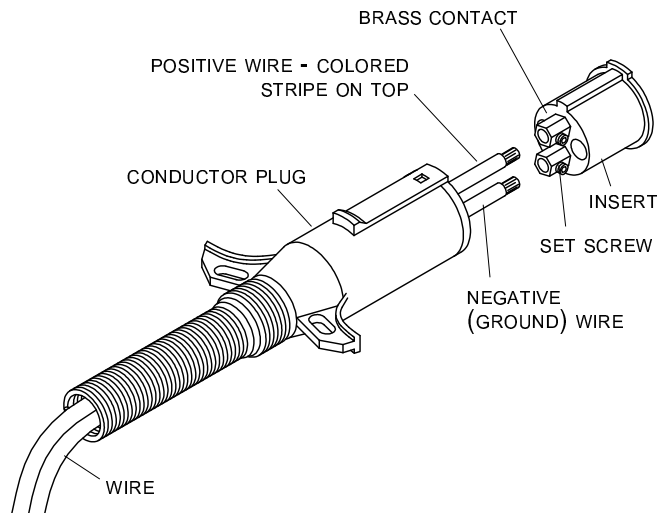

STEP 1: Mounting bracket. Mount bracket at suitable location on front of trailer, usually near existing plugs. Mark and drill 5/16" holes and fasten with 3/8" x 1" self-tapping screws, lock washers and nuts.

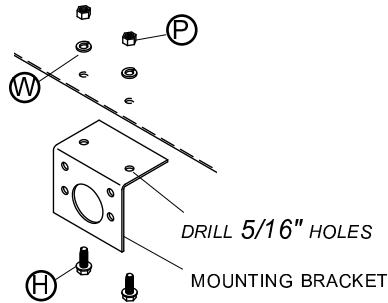

STEP 2: Conductor socket. Fasten conductor socket to mounting bracket with 5/16" x 3/4" cap screws and lock nuts. Bring 6-ga. wire from lower end of pivot arm through sealed boot. Connect wire ends to conductor socket, aligning positive wire on socket with positive wire on conductor plug. Slide sealed boot against conductor socket and secure boot to wire with cable tie.

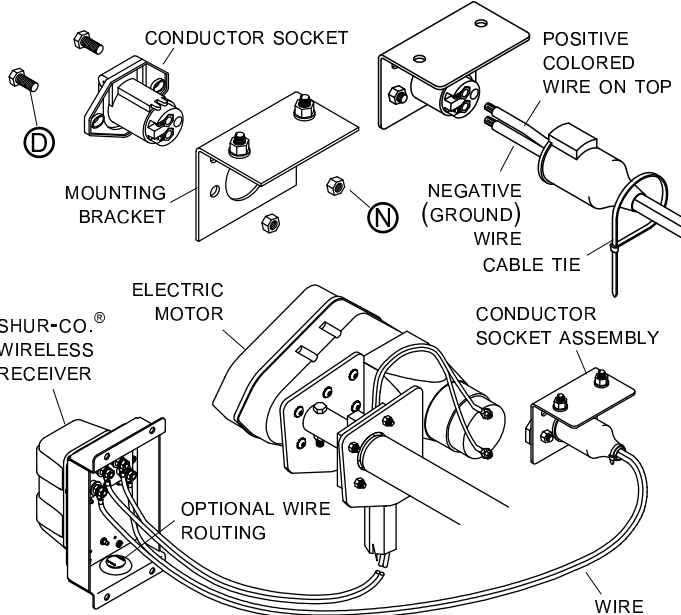

STEP 3: Shur-Co® wireless receiver. Identify 6-ga. wire running from electric motor through front pivot arm. Route wire as desired. Insert end of this wire through rubber boots, then crimp 1/4" ring terminals onto wire ends. Remove nuts and lock washers from back of wireless receiver. Place positive wire on upper orange post and negative wire on upper black post. Secure lock washers and hex nuts. Coat with dielectric grease and install rubber boots over ring terminals.

USE DIELECTRIC GREASE (PART #1704378) TO PREVENT CORROSION ON TERMINALS.

Run section of 6-ga. wire, long enough to reach socket, through rubber boots. Crimp 1/4" ring terminals to wire ends. On back of wireless receiver, place positive wire on lower orange post and negative wire on lower black post. Secure with 1/4" lock washers and hex nuts. Coat with dielectric grease and install rubber boots over ring terminals. When wiring socket align positive wire with positive wire on plug.

Mount wireless receiver at suitable location on front of trailer. Mark and drill 11/32" holes and fasten with 5/16" x 1" self-tapping screws, flat washers and lock nuts.

NOTE: If using self-tapping screws only, trailer wall thickness must be at least 3/16". Drill 1/4" holes.

STEP 4: Connect wires at top of pivot arm to motor.

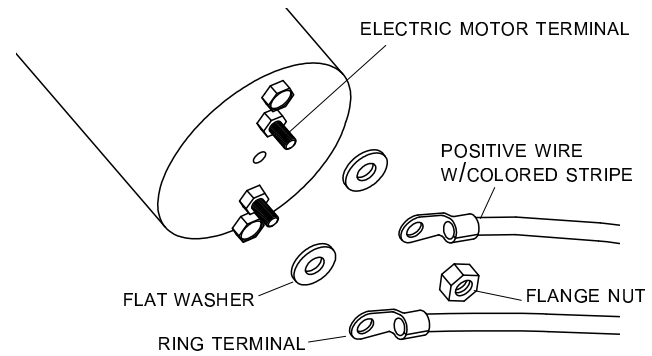

CAUTION

Check all hardware for complete assembly before operating. Inspect system at this time and adjust as required.

OPERATION:

A) Check motor direction by activating switch to "OPEN". If switch is running system backwards, change wire leads on motor to opposite connections.

B) Close tarp: Push switch to "CLOSE" and hold. Observe tarp and release switch when tarp is fully closed.

C) Open tarp: Push switch to "OPEN" and hold. Observe tarp and release switch when tarp is fully open.

NOTE: Release switch at end of cycle or modified-reset circuit breaker will trip. After breaker resets, switch will activate motor again. To reduce unnecessary strain on tarp components, release switch at end of each cycle.

NOTE: Pressure wash - Receiver may be pressure washed, but keep nozzle at least 3' from system while spraying.

Power-Up/Down:

The transmitter will power up when the lid is opened. The transmitter will power down when the lid is closed or when the lid is left open three minutes after the last button is pushed.

Standard Operation:

After power-up, the first channel will be immediately active and the LED indicator for this channel will be flashing. The *Open/On* and *Close/Off* buttons are operational for the indicated active channel. While pressed, the LED indicator will flash faster, indicating channel operation.

The *Select* button will cycle between enabled channels. If only one channel is enabled, there will be no apparent change when the *Select* button is pressed.

Channel Programming Mode:

The Shur-Co® SMARTransmitter® has five channels. Pressing the *Select* button toggles through these channels. Unused channels can be disabled if desired, using the following process, but your transmitter is fully operational as shipped. This process may be skipped. Unused transmitter channels will not perform any functions.

Hold the *Select* button down for 10 seconds and the transmitter will enter *Channel Programming Mode*. Each time *Channel Programming Mode* is entered, the status of all five channels must be reset.

While In *Channel Programming Mode*, the programmable channel will be indicated by a solid lit LED.

NOTE: The transmitter will NOT activate any motor or lighting system while the transmitter is in *Channel Programming Mode*.

Press the *Open/On* button to enable the current channel (designated by the indicator light). Press the *Close/Off* button to disable the current channel. The indicator light will automatically jump to the next channel.

After programming all five channels, the transmitter will display the programmed channel status for all channels for three seconds. All enabled channel LEDs will be lit solid and all disabled channel LEDs will not be lit. Buttons will not function during this three second period.

The transmitter will automatically exit *Channel Programming Mode* after three seconds and return to *Operational Mode*.

NOTE: If there is not at least one enabled channel after programming, the transmitter will not save the changes and will revert back to the previously saved channel settings.

TIP: To cancel your changes and exit *Channel Programming Mode*, close the transmitter cover.

Channel Programming Example:

The transmitter in this example is labeled with the following five channels:

Tarp System
Front Hopper
Back Hopper
Lights
Auxiliary

These channel labels are for a standard agricultural transmitter. Your transmitter label may differ.

The task is to enable the *Tarp System*, *Front Hopper* and *Back Hopper* channels.

1. Hold down the *Select* button for 10 seconds. The transmitter will enter *Learn Mode*. The *Tarp System* channel LED will be lit. All other channel LEDs are off.
2. Press the *Open/On* button to enable the *Tarp System* channel. The *Front Hopper* LED will now be lit.
3. Press the *Open/On* button to enable the *Front Hopper*. The *Back Hopper* LED will be lit.
4. Press the *Open/On* button to enable the *Back Hopper*. The *Lights* channel LED will be lit.
5. Press the *Close/Off* button to disable the lights. The *Auxiliary* LED will be lit.
6. Press the *Close/Off* button to disable the *Auxiliary* channel LED.
7. The transmitter will display all activated channels for three seconds. The transmitter will automatically exit *Channel Programming* and revert to *Operational Mode*. The *Tarp System* LED will be flashing, indicating that the channel is active and ready for operation.

SMARTransmitter® to Receiver Programming:

Shur-Co® SMARTrailer® wireless systems are typically pre-programmed at the factory or by the dealer and should be ready to use as shipped. Re-programming is necessary after replacement transmitters or receivers are installed.

Use the following method to program the RF receiver to accept and respond to signals from up to five transmitters. The receiver will not accept or respond to signals from transmitters that have not been programmed using this method.

1. Remove the receiver cover, pulling gently on the cover to prevent damage to wires that are connected to the rocker switch.
2. Check to be sure the 3500 is connected to the power supply. The receiver must be connected to power to be programmed. If a battery disconnect switch is installed, make sure it is turned on.
3. The receiver can learn to recognize and respond to up to five transmitters. Gather all of the transmitters to be introduced to the receiver. Open the transmitter lid(s) in order to turn them on.
4. Set the transmitter(s) to the appropriate channel (*Tarp System*, etc.). See *Transmitter Operation & Programming Instructions*.

NOTE: Read the following steps in their entirety before proceeding. steps 6 to 8 must be completed within 10 seconds.

5. Press and hold the programming button on the bottom of the RF solenoid for five seconds. The solenoid will beep to indicate that it is in programming mode. Release the programming button.
6. Press the *Open/On* button on the first transmitter being introduced. The receiver will beep after receiving the transmitter signal.
7. Repeat step 6 for any remaining transmitters.
8. The receiver will expect five signals, so if you are programming less than five transmitters, press the *Open/On* button additional times on the last transmitter you are programming. Push the *Open/On* button a total of five times (see programming example).
9. After pushing the *Open/On* button five times, the receiver will beep twice to indicate that it has been programmed successfully.

NOTE: The Receiver will exit program mode after 10 seconds, whether or not it has five *Open/On* button signals.

10. Verify that each transmitter is operating correctly. If none of the transmitters are operating correctly, verify that there are 12 to 14 volts from the receiver positive to negative, then repeat steps 3 to 9.

11. Refasten receiver cover.

Receiver Programming Example:

In this example, the receiver controls the 3500 motor. The task is to program the receiver to recognize three transmitters.

1. Remove the receiver cover and turn on the three transmitters.
2. Set all three transmitters to the tarp system channel.
3. Press and hold the programming button on the RF solenoid for five seconds. The solenoid will beep to indicate it has entered *Channel Programming Mode*. Release the programming button.
4. Press the *Open/On* button on the first transmitter. The receiver will beep to indicate that it has received a signal and memory slot #1 has been filled.
5. Press the *Open/On* button on the second transmitter. The receiver will beep to indicate that it has received a signal and memory slot #2 has been filled.
6. Press the *Open/On* button on the third transmitter. The receiver will beep to indicate that it has received a signal and memory slot #3 has been filled.
7. Press the *Open/On* button on the third transmitter again. The receiver will beep to indicate that it has received a signal and memory slot #4 has been filled.
8. Press the *Open/On* button on the third transmitter again. The receiver will beep twice to indicate that it has received a signal, and memory slot #5 has been filled. The double beep also indicates that the receiver has exited programming mode.
9. Verify that the tarp system *Open* and *Close* operations are functioning correctly on all three transmitters.
10. Refasten the receiver cover to motor assembly.

WARNING
 Flex arms are under tension while torsion springs are engaged. Use caution while assembling and disassembling arms. Failure to read and follow instructions could result in serious injury or death.

NOTE: Store manual crank arm either in truck or mounted to trailer. (Example - above kingpin in apex).

Perform the following steps to change your 3500 Series Electric system to a manual crank operation:

STEP 1: Close tarp but let roll tube hang loose under latchplate. Remove 3/8" x 2 1/2" cap screw and lock nut from Gate Flex™.

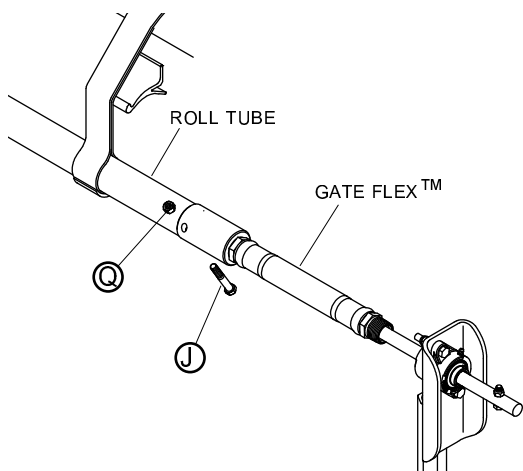

STEP 2: Carefully slide Gate Flex™ off roll tube. Flex arm will be under tension and have some downward force.

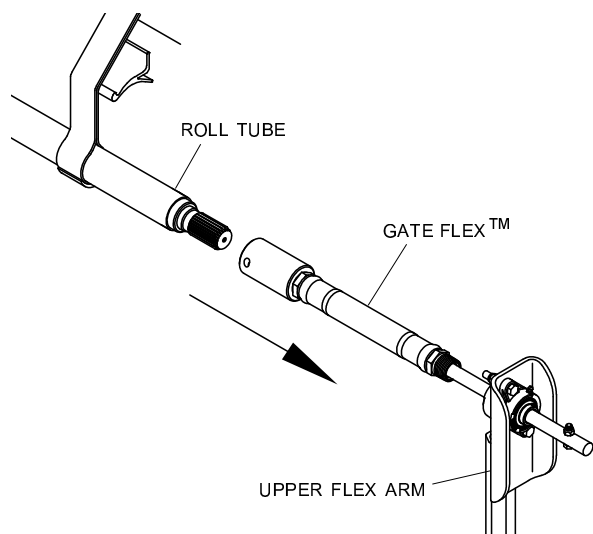

STEP 3: Remove retaining ring on rear flex arm. Carefully slide arm off from pivot pin.

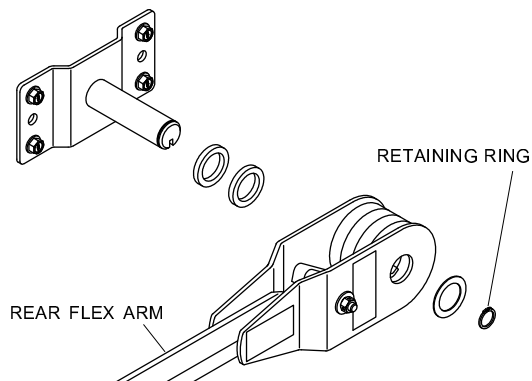

STEP 4: At front of trailer, remove 3/8" x 2 1/4" cap screw from motor shaft and roll tube extension connection.

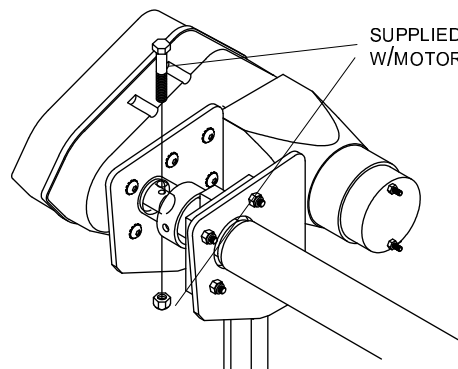

STEP 5: Install crank arm assembly as shown in Shur-Lok® owner's manual. Owner's manual may be viewed at <http://www.shurco.com>. May need optional manual override extension kit - part number 1117022.

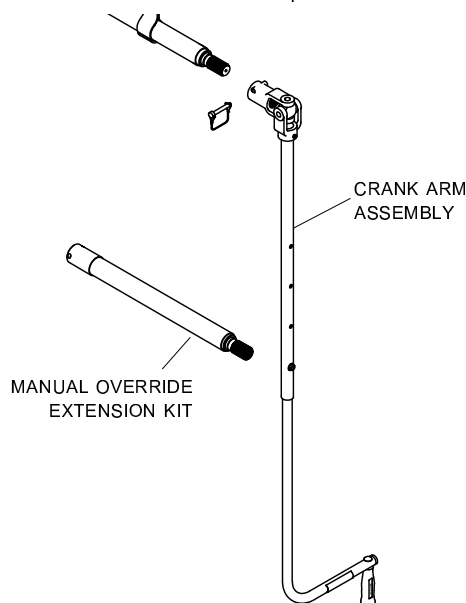

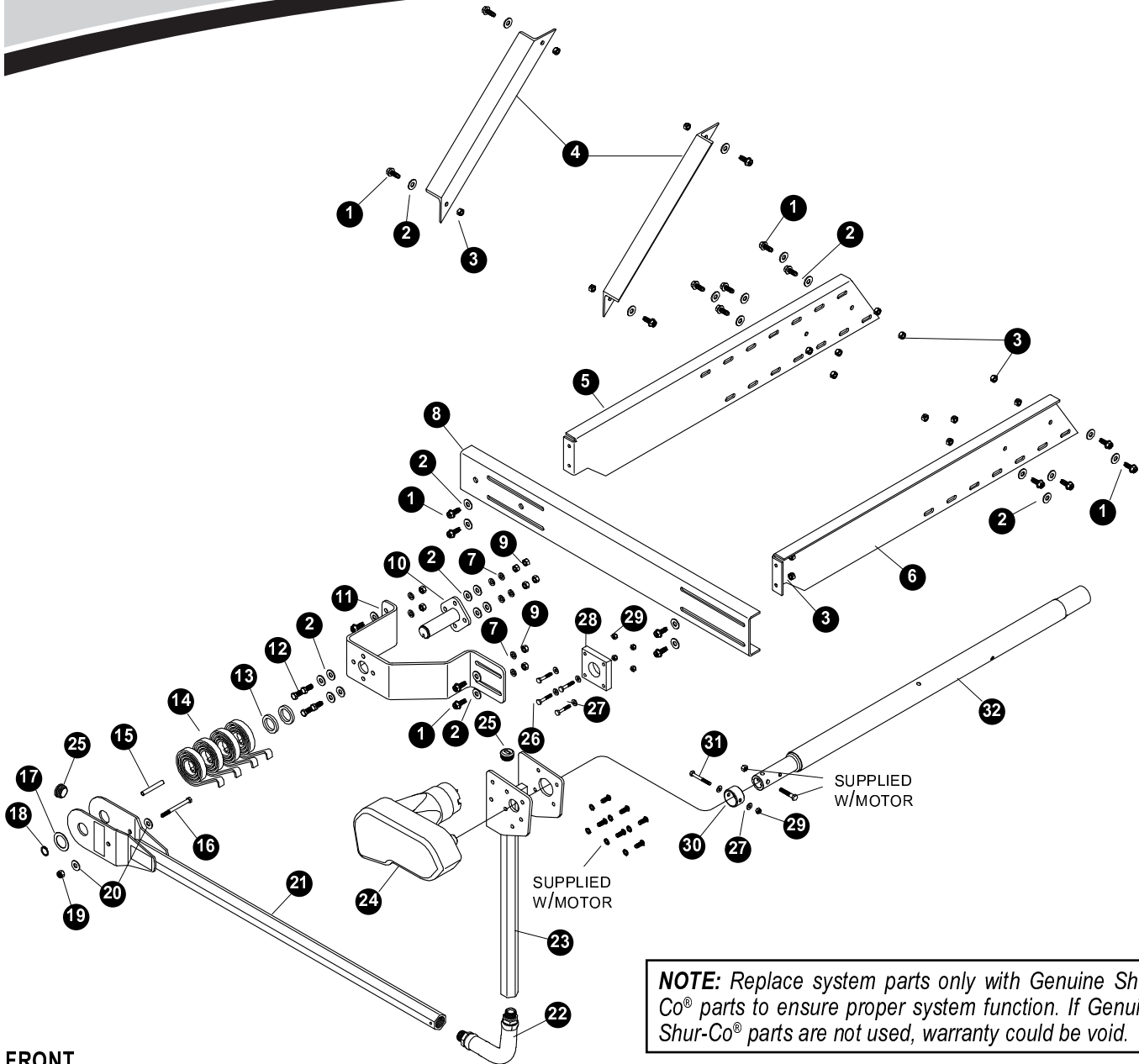

FRONT

Item	Part #	Description
1.	1700400	Self-Tapping Screw - 3/8" x 1"
2.	1700429	Flat Washer - 3/8"
3.	1700418	Centerlock Nut - 3/8"
4.	1112310	Extended Extension Support Bracket
5.	1113306	Universal Extension Bracket Passenger Side
6.	1113307	Universal Extension Bracket Driver Side
7.	1700434	Lock Washer - 3/8"
8.	1112178	Sloped Front Mounting Bracket
9.	1700407	Hex Nut - 3/8"
10.	1116920	Pivot Pin - 4 Spring
11.	1116919	Pivot Mount Bracket - 7 1/4" Standoff
12.	1702891	Cap Screw - 3/8" x 1 1/4"
13.	1118318	Spacer Washer - 1/4" x 1.81" OD x 1.28"
14.	1111027	Spiral Torsion Spring
15.	1117033	Spacer Tube - .35" x 2 5/8"
16.	1201022	Cap Screw - 5/16" x 3 1/2"

Item	Part #	Description
17.	1702890	Flat Washer - 1 1/4"
18.	1702888	Retaining Ring - 1 1/4"
19.	1700419	Nylon Lock Nut - 5/16"
20.	1700428	Flat Washer - 5/16"
21.	1116905	Lower Flex Arm
22.	1703873	Flex Arm Joint
23.	1118015	Upper Flex Arm - Motor Side
24.	1703135	Heavy-Duty Motor
25.	1703882	Cap Plug w/Hole - 1 1/4" x 14-16 Ga.
26.	1700377	Cap Screw - 1/4" x 1 1/2"
27.	1700427	Flat Washer - 1/4"
28.	1110408	Flange Bearing
29.	1701543	Nylon Lock Nut - 1/4"
30.	1116924	Manual Override Collar
31.	1702672	Cap Screw - 1/4" x 2 1/4"
32.	1112954	Roll Tube Extension w/Drive Shaft - 77.313"

NOTE: Replace system parts only with Genuine Shur-Co® parts to ensure proper system function. If Genuine Shur-Co® parts are not used, warranty could be void.

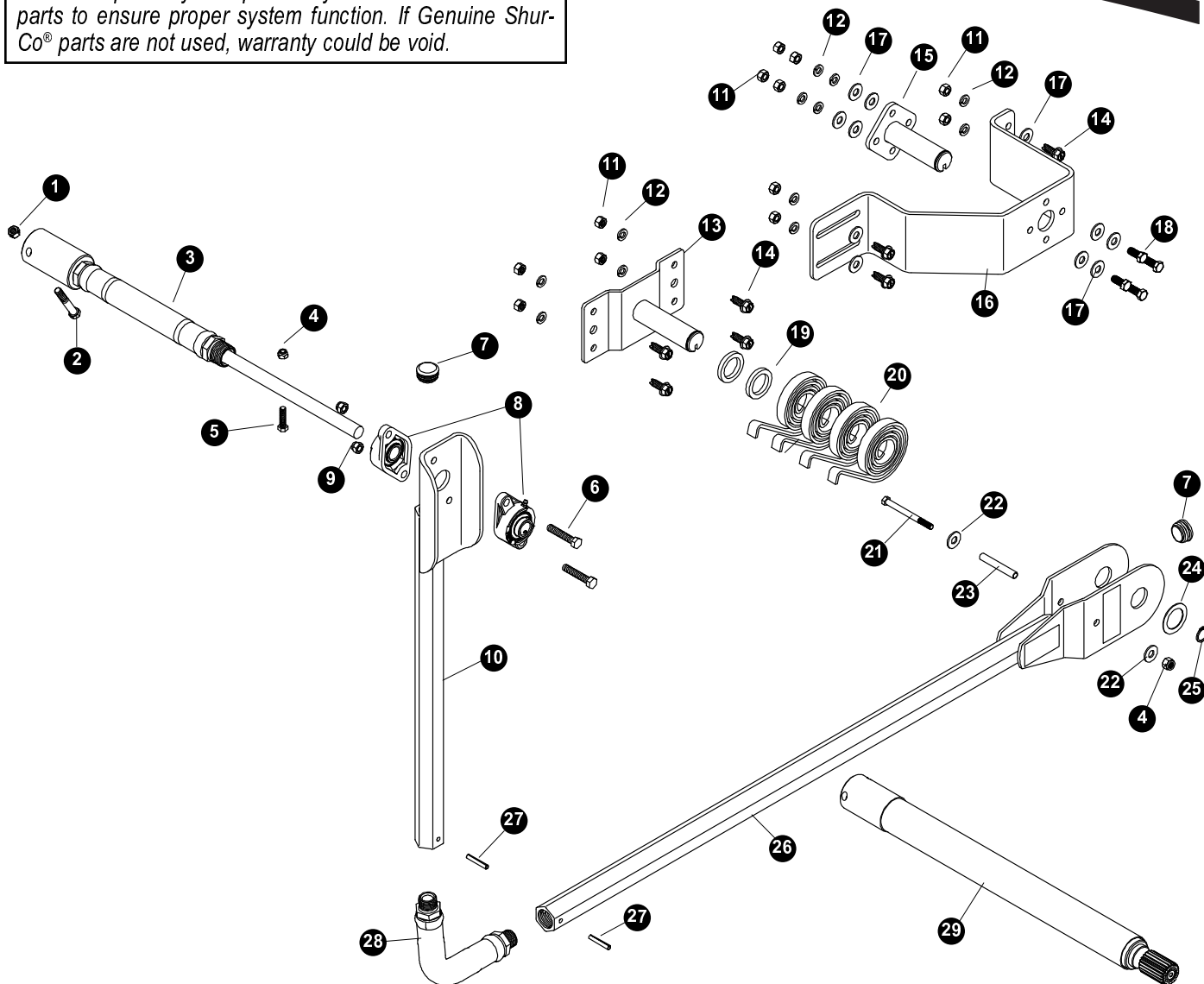

REAR

Item	Part #	Description
1	1700418	Centerlock Nut - 3/8"
2	1702573	Cap Screw - 3/8" x 2 1/2"
3	1116990	Gate Flex™
4	1700419	Nylon Lock Nut - 5/16"
5	1703487	Cap Screw - 5/16" x 1 1/2"
6	1704264	Cap Screw - 3/8" x 2"
7	1703881	Cap Plug - 1 1/4" x 14-16 Ga
8	1704703	Flange Bearing - 20mm - 2 Bolt
9	1701580	Nylon Lock Nut - 3/8"
10	1116992	Upper Flex Arm - Gate Flex™
11	1700407	Hex Nut - 3/8"
12	1700434	Lock Washer - 3/8"
13	1116994	Pivot Bracket - Sloped - Gate Flex™
14	1700400	Self-Tapping Screw - 3/8" x 1"

Item	Part #	Description
15.	1116920	Pivot Pin - 4 Spring
16.	1116919	Vertical Pivot Mount Bracket - 7 1/4" Standoff
17.	1700429	Flat Washer - 3/8"
18.	1702891	Cap Screw - 3/8" x 1 1/4"
19.	1118318	Spacer Washer - 1/4" x 1.81" OD x 1.28"
20.	1111027	Spiral Torsion Spring
21.	1201022	Cap Screw - 5/16" x 3 1/2"
22.	1700428	Flat Washer - 5/16"
23.	1117033	Spacer Tube - .35" x 2 5/8"
24.	1702890	Flat Washer - 1 1/4"
25.	1702888	Retaining Ring - 1 1/4"
26.	1116905	Lower Flex Arm
27.	1700445	Spring Pin - 1/4" x 1 1/2"
28.	1703873	Flex Arm Joint
29.	1117022	Manual Override Extension Kit (optional)

3500 ELECTRIC COMPONENTS

Item	Part #	Description
	1116473	Cab Wiring Kit - Rocker Switch
	1116928	Cab Wiring Kit - SMARTransmitter®
	1116929	Trailer Wiring Kit - SMARTransmitter®
	1116930	Trailer Wiring Kit - Rocker Switch
	1118368	Electric Parts Kit w/Rocker Switch - 40-Amp Mod.
	1118257	Shur-Co® Wireless Receiver
1.	1703245	Ring Terminal - 6 Ga. x #10 Stud - Motor/Breaker
2.	1703244	Ring Terminal - 6 Ga. x 3/8" Stud - Battery
3.	1704153	Ring Terminal - 14 Ga. x 1/4" Stud - Solenoid
4.	1703659	Push On Terminal - 14 Ga. 1/4" - Switch/Solenoid
5.	1702707	Ring Terminal - 6 Ga. 1/4 Stud - Motor/Solenoid
6.	1118437	5-Channel SMARTransmitter® Battery
	1704597	SMARTransmitter® Replacement Battery
7.	1704330	Rubber Boot
8.	1704308	Cap Screw - #10 x 1/2"
9.	1120695	Motor Reversing Solenoid - RF
10.	1704343	Cap Screw - 1/4" x 1 1/2"
11.	1700408	Hex Nut - 1/4"
12.	1700427	Flat Washer - 1/4"
13.	1118296	Modular Control Bracket
14.	1118297	Insulating Plate
15.	1703282	Rubber Grommet - 1 1/4" Insert
16.	1701595	End Plug - 1" x 14-23 Ga.
17.	1118037	Black Plastic Washer
18.	1118250	Orange Plastic Washer
19.	1700436	Lock Washer - 1/4"
20.	1118340	Solenoid Cover/Gasket
21.	1704369	Trim Seal
22.	1703822	Dual Conductor Wire - 6 Ga. 259-Strand
23.	1116482	Electrical Wire - 14 Ga. 3 Lead - 15'
24.	1704354	40-Amp Modified Reset Circuit Breaker
25.	1116020	Rocker Switch
26.	1703661	Rocker Switch Mounting Bracket
27.	1703231	Cable Tie - 8"
28.	1703845	Motor Reversing Solenoid
29.	1703896	Solenoid Cover
30.	1700381	Cap Screw - 1/4" x 1"
31.	1701543	Nylon Lock Nut - 1/4"
32.	1115385	Heavy-Duty Dual Conductor Plug
33.	1119557	Heavy-Duty Dual Conductor Socket
	1704573	Conductor Socket Sealing Boot
34.	1700407	Hex Nut - 3/8"
35.	1700434	Lock Washer - 3/8"
36.	1700411	Hex Nut - 5/16"
37.	1701045	Cap Screw - 5/16" x 3/4"
38.	1109015	Mounting Bracket
39.	1700400	Self-Tapping Screw - 3/8" x 1"
40.	1702108	Wire Clip - 3/4"
41.	1704338	Self-Tapping Screw - 1/4" x 1"

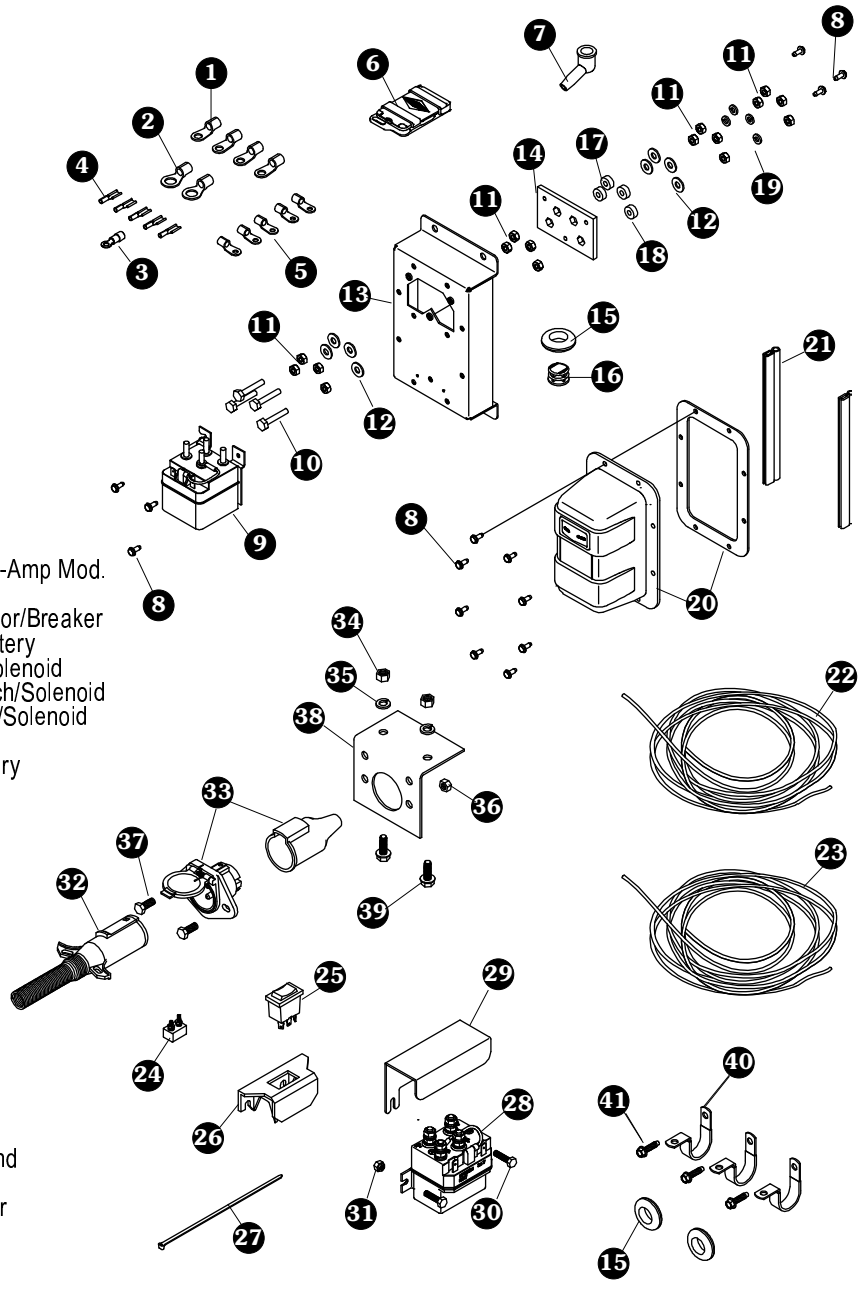

Our **Advanced Troubleshooting Guide** is available on our website: <http://www.shurco.com>, or call our Help Line: **1-866-748-7435**.

PROBLEM:	TRY THIS:
<p>The SMARTransmitter® is not working.</p> <p>None of the lights on the remote turn on when I open the lid.</p>	<ol style="list-style-type: none"> 1. Make sure the battery is placed correctly. 2. The battery may be dead and must be replaced. Replacement high-capacity SMARTremote® batteries may be purchased from Shur-Co® (part #1704597). 3. The SMARTransmitter® may be damaged. Call Shur-Co's Help Line.
<p>The SMARTransmitter® is not working.</p> <p>I can operate the system with the rocker switch but not with the remote. The SMARTransmitter® channel light (<i>Tarp System</i>, for example) is blinking and when I press the <i>Open/On</i> button the light blinks faster.</p>	<ol style="list-style-type: none"> 1. Make sure the remote is set to the right channel. If you cannot set the remote to the desired channel (<i>Tarp System</i>, for example), the remote must be reprogrammed. See the SMARTransmitter® programming instructions. 2. Make sure you are within a couple feet of the receiver and try again. <ul style="list-style-type: none"> a) If it works at short range but not at greater distances, you have a range problem. A new battery may be needed. If the remote battery is not the cause, call Shur-Co's Help Line. 3. Reprogram the receiver. See the receiver programming instructions. If this doesn't work, call Shur-Co's Help Line.
<p>The system will not operate with the rocker switch or with the SMARTransmitter®.</p> <p>When I try to use the rocker switch or SMARTransmitter®, I don't hear any noises (a clicking noise for example) from the receiver.</p>	<ol style="list-style-type: none"> 1. Make sure the master disconnect switch is turned to the "ON" position. 2. The circuit breaker may have tripped. Wait one minute and try again. 3. Check the vehicle's battery to make sure it isn't dead. 4. Check all connections from the battery to the system. Check for polarity, good connections and corrosion. Verify that you have at least 12V on the back side of the receiver on the battery hookup posts. 5. Call Shur-Co's Help Line.

PROBLEM:	TRY THIS:
<p>The system will not operate with the rocker switch or with the SMARTransmitter®.</p> <p>When I try to use the rocker switch or SMARTransmitter® I hear a clicking noise but nothing happens.</p>	<ol style="list-style-type: none"> 1. Verify you have at least 12V on the back side of the receiver on the battery hookup posts. 2. Call Shur-Co's Help Line.
<p>The rocker switch is not sticking, but the motor continues to run after I release the rocker switch.</p>	<ol style="list-style-type: none"> 1. Call Shur-Co's Help Line.
<p>The rocker switch is sticking.</p>	<ol style="list-style-type: none"> 1. Check the switch for excessive dirt, rocks or other objects. If the rocker switch cannot be cleaned, call Shur-Co's Help Line for a replacement receiver. <p>Pressure Wash: The receiver may be pressure washed, but keep nozzle at least three feet from system while spraying.</p>

Our **Advanced Troubleshooting Guide** is available on our website: <http://www.shurco.com>, or call our Help Line: **1-866-748-7435**.

MORE QUALITY PRODUCTS FROM SHUR-CO®

- **Genuine Replacement Tarps**
- **Genuine Replacement Parts**

- **Agriculture Products**
 - Value Series Shur-Lok®
 - Super Duty Shur-Lok®
 - Shur-Lok® Junior
 - Premium Belt 'n Ratchet
 - Cable-Lok™
 - Turning Point™ Bow

- **SMARTrailer™ Accessories for Agriculture Products**
 - SMART2™ Remote
 - SMART1 +™ Remote
 - 4500 Series HD Electric
 - Electric Shur-Lok®
 - AutoTrap™ Hopper Opener
 - ProTrap® Hopper Opener
 - Electric Gate & Hoist
 - LiteALL™ Work Lights
 - Cable-Lok™ Electric Upgrade
 - Electric Turning Point™ Bow
 - Solar Power Pack

- **Flatbed Products**
 - ShurTite™ Retractable Tarps
 - Stock Lumber & Steel Tarps

- **Custom Products**
 - Fitted Truck Covers
 - Flat Utility Tarps
 - Bean Drill Covers
 - Shur-Lok® Tarp Cords
 - Gustbuster™ Tarp Cords

- **Construction Products**
 - Super Duty Shur-Lok®
 - Shur-Trak II™
 - Cover-Pro II®
 - Turning Point™ Bow
 - IronSide™ Side-Dump System
 - Arm-Matic™
 - DuraPull™
 - Econo-Pull™
 - Turbo Tarp2™
 - 2000 Series
 - 5000 Series
 - Hammer™
 - Bullet™
 - Flash™
 - Long Arm™

- **SMARTrailer™ Accessories for Construction Products**
 - 4500 Series HD Electric w/Gate Flex™
 - Shur-Trak II™ Electric Upgrade
 - Cover-Pro II® Electric Upgrade
 - Electric Turning Point™ Bow
 - Solar Power Pack

- **Waste Products**
 - The Ox™
 - Quick-Flip III™
 - Sidewinder™
 - Sidewinder™ 350
 - HyTower™ SL
 - HyTower™ DL
 - Double-Flip™

TARPING SYSTEMS & ACCESSORIES

