



TARPING SYSTEMS & ACCESSORIES

P/N 1122107 Rev. P

# OWNER'S MANUAL



## Aluminum System for Grain Trailers

REVERSE ROLL

*READ BEFORE INSTALLING*

PO BOX 713 ■ 2309 SHUR-LOK STREET ■ YANKTON, SD 57078-0713  
PHONE 1-800-4-SHUR-LOK (1-800-474-8756) ■ FAX 605-665-0501  
[www.shurco.com](http://www.shurco.com)

SHOP ONLINE: [www.shopshurco.com](http://www.shopshurco.com)

**SHIPPING.** Orders are shipped F.O.B. from the Shur-Co®, LLC sites listed below. No full freight is allowed or prepaid shipment accepted unless quoted and approved in writing prior to acceptance of the order. All shipments are made by the most reasonable means in accordance with size and weight of order, unless specified routing instructions are furnished by the customer. Shipments are made daily via U.P.S. and common carrier. Claims for shortages must be made within 10 days. All claims for damages or loss in transit must be made with the carrier. No collect calls will be accepted. To ensure delivery of orders, we need your full street address and phone number. When you receive your shipment, examine it carefully. Be sure all cartons listed on the delivery sheet are accounted for. Large items may be packaged separately. If a carton is damaged, open it and inspect the contents before signing for delivery. If merchandise is damaged, describe damage on the delivery receipt. Failure on your part to document damaged or missing merchandise on the delivery receipt releases the carrier of all liability; repair or replacement will be the customer's responsibility.

**WARRANTY.** We warrant all new products are free of defects in materials and workmanship.\* This warranty is effective if products are properly installed and used for the purpose for which they were intended and applies to the original buyer only. Except as set forth above or in any product-specific warranty documentation, we make no other warranties, express or implied, including but not limited to warranties of merchantability of fitness for a particular use.

Returns of a product for warranty must be accompanied by a Return Merchandise Authorization number (RMA#), obtained by calling Customer Service at 866-748-7435, and sent, with freight paid by us, to Shur-Co®, LLC, 2309 Shur-Lok St., PO Box 713, Yankton, SD 57078. All products returned without an RMA# will be refused. When we issue the RMA#, we will also issue a call tag to have UPS (or other freight company) pick up the product. C.O.D. returns not accepted. We will pay no storage fees for a warranty product return prior to pick by us or the freight company. If a warranty product return is scheduled to be picked up by us, we will pick up the product at our earliest convenience.

If a product returned is found, in our judgement, to be defective in material or workmanship, our obligation under this warranty is limited to the repair or replacement of the product, which will be made by us. Repair or replacement will be at our discretion, with replacements being made using current products performing in the equivalent function. Labor charges, other than those incurred at our factory, including, but not limited to, any labor to install a repaired or replacement product, are not covered under this warranty. All expenses associated with delivering defective products to our factory and delivering repaired or replacement products from our factory to the owner will be paid by us.

If the product returned is found, in our judgement, to be non-warrantable, the owner will be contacted to authorize repair work, purchase of a replacement product or return of the product, all of which will be at the owner's expense. Payment authorization must be received by us before any non-warrantable product is repaired, replaced or returned. All expenses associated with delivering the repaired non-warrantable product, a replacement product or the non-warrantable product from our factory to the owner will be paid by the owner.

In no event will we be liable for any damages of any kind to person, product or property, including but not limited to indirect, incidental, special, consequential or punitive damages, or damages for loss of profits or revenue, even if we have been advised of the possibility of such damages. There are no warranties for used products or products that have been repaired, altered, modified or subjected to misuse, negligence or accident. We will not repair or replace products that fail or malfunction due to ordinary wear and tear, except as expressly noted in a product-specific warranty. Use of non-Shur-Co®, LLC parts in conjunction with Shur-Co®, LLC products will void this product warranty.

\*Certain products have specific warranties that differ from this warranty, for example motors and electronics. Product-specific warranty documentation is available for these items. In the event of a conflict between this warranty and a product-specific warranty, the product-specific warranty will govern.

**RETURN POLICY.** All sales final. See WARRANTY above for return details.

**OTHER.** All prices, product listings, sizes, weights and manufacturing details are subject to change without notice. No person is authorized to modify the foregoing conditions of sale whatsoever.

## SHUR-CO®, LLC SERVICE AND DISTRIBUTION CENTERS

### *Corporate HQ and Outlet Store*

#### **SHUR-CO® of SOUTH DAKOTA**

2309 Shur-Lok St., PO Box 713, Yankton, SD 57078  
Ph 800.474.8756 | Fax 605.665.0501

#### **SHUR-CO® of FLORIDA**

3353 SE Gran Park Way, Stuart, FL 34997  
Ph 800.327.8287 | Fax 772.287.0431

#### **SHUR-CO® of IDAHO**

610 N. 16th Ave., Caldwell, ID 83607  
Ph 866.356.0246 | Fax 217.877.8270

#### **SHUR-CO® of ILLINOIS**

3993 E. Mueller Ave., Decatur, IL 62526  
Ph 866.356.0246 | Fax 217.877.8270

#### **SHUR-CO® of NORTH DAKOTA**

1746 4th Ave. NW, West Fargo, ND 58078  
Ph 877.868.4488 | Fax 701.277.1283

#### **SHUR-CO® of OHIO**

4676 Lynn Rd.  
Rootstown, OH 44266  
Ph 866.356.0242 | Fax 330.297.5599

#### **SHUR-CO® of VERMILLION**

1212 N. Norbeck St., Vermillion, SD  
Ph 800.474.8756 | Fax 605.665.0501

#### **SHUR-CO® of CANADA**

490 Elgin St., Unit #1  
Brantford, Ontario N3S 7P8  
Ph 800.265.0823 | Fax 519.751.3997

#### **SHUR-CO® UK, Ltd.**

Unit 41 Rochester Airport Estates  
Laker Rd., Rochester, Kent ME1 3QX  
Ph +44 (0)1795.473499  
Fax +44 (0)871.272.8278

For more information, log on to our website:

**[www.shurco.com](http://www.shurco.com)**

**MESSAGE TO OWNERS**

Thank you for buying this tarping system from Shur-Co®. We appreciate your confidence in our products. Please read and thoroughly understand this manual before installing and/or operating this system.

Pay particular attention to important safety and operating instructions, as well as warnings and cautions. The hazard symbol  is used to alert users to potentially hazardous conditions and is followed by caution, warning or danger messages.

Failure to READ AND FOLLOW INSTRUCTIONS could result in failure of your tarping system and/or personal injury. Your trailer requirements may, however, call for minor variations to these instructions.

Please inspect your tarping system periodically. Repair or replace worn or damaged parts to your system.

QUESTIONS? CALL OUR HELP LINE:  
**1-866-748-7435**  
 MON-FRI 8 AM-5 PM CENTRAL TIME

**SAFETY**

We at Shur-Co® are concerned with your safety and the safety of all those operating this system. Therefore, we have provided safety decals at various locations on your tarping system. Keep decals as clean as possible at all times. Replace any decal that has become worn or damaged, painted over or otherwise difficult to read. Replacement decals are available through Shur-Co® dealers.

**SAFETY INSTRUCTIONS**

- 1. Always wear safety glasses during installation and operation.**
- 2. Stay clear of moving parts.**
- 3. No other use of this system is authorized, except as designed.**

**RUST PREVENTION**

To prevent rust, paint all exposed metal, such as weld seams and/or metal exposed by grinding or cutting, with corrosion-resistant paint.

**TABLE OF CONTENTS**

Hardware Identification ..... 1  
 Pivot Bracket Installation Front & Rear.....2-5  
 Pivot Bracket Installation .....6  
 Front Flex Arm & Electric Motor Installation .....7-8  
 Rear Flex Arm Installation - 2" Roll Tube.....9-10  
 Rear Flex Arm Installation - 3" Roll Tube.....11-12  
 2" Roll Tube Extension Installation .....13-15  
 3" Roll Tube Extension Installation .....16-18  
 Electric Mounting & Wiring .....19-24  
 Operation.....25  
 Conversion to Manual Power .....26  
 Electric Motor Replacement .....27  
 Replacement Parts.....28-32

**TOOLS REQUIRED**

1. Welder
2. Hammer
3. Center Punch or Transfer Punch
4. #3 Phillips Insert Bit
5. Air or Electric Impact Wrench (9/16" deep socket)
6. 7/16" Deep Socket
7. 3/8" Combination Wrench
8. 9/16" Combination Wrench
9. 1/2" Combination Wrench
10. 1/8" Hex Wrench Long T-Handle
11. 3/16" Hex Wrench Long T-Handle (recommended)
12. 7/32" Drill Bit
13. 5/16" Drill Bit (for 3/8" self-tapping screws)
14. 11/32" Drill Bit
15. 13/32" Drill Bit
16. 3/8" Drill
17. 1 1/8" Hole Saw
18. 1 1/2" Hole Saw
19. 2" Hole Saw (if bracket for conductor socket is not used)
20. Standard/Flathead Screwdriver
21. #2 Phillips Screwdriver
22. Utility Knife
23. Ratchet
24. Hack Saw (metal cutter)
25. Pliers
26. Snap-Ring Pliers
27. Wire Cutters
28. Grinder
29. Tape Measure

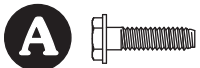

**A** 1704367 Cap Screw - #10 x 3/4"

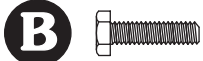

**B** 1704905 Flanged Cap Screw - #10 x 1"

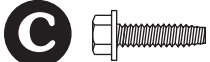

**C** 1704905 Hex Flanged Cap Screw #10 x 1"



**D** 1703959 Cap Screw 1/4" x 3/4"

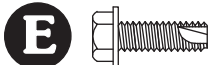

**E** 1700403 Self-Tapping Screw - 1/4" x 3/4"



**F** 1700398 Self-Drilling Screw - 1/4" x 3/4"

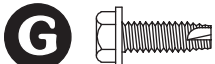

**G** 1704338 Self-Tapping Screw - 1/4" x 1"

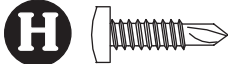

**H** 1705198 Self-Drilling Screw - 1/4" x 1"

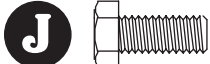

**J** 1701045 Cap Screw - 5/16" x 3/4"

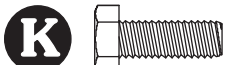

**K** 1702926 Cap Screw - 5/16" x 7/8"

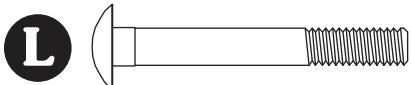

**L** 1701455 Carriage Bolt - 5/16" x 2 1/2"



**M** 1201022 Cap Screw - 5/16" x 3 1/2"

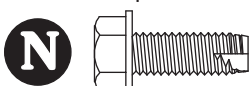

**N** 1700400 Self-Tapping Screw - 3/8" x 1"

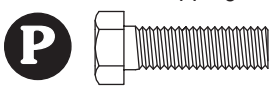

**P** 1702891 Cap Screw - 3/8" x 1 1/4"



**Q** 1704264 Cap Screw - 3/8" x 2" - Grade 8

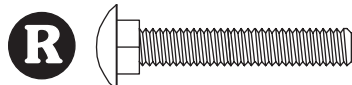

**R** 1704237 Carriage Bolt - 3/8" x 2"

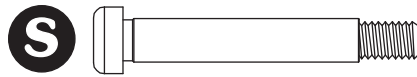

**S** 1704943 Shoulder Bolt - 3/8" x 2  
- 5/16" x 1/2" Thd.



**T** 1808844 Nylon Lock Nut - #10



**U** 1701543 Nylon Lock Nut - 1/4"



**V** 1700408 Hex Nut 1/4"

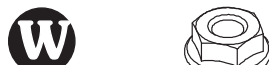

**W** 1704946 Flanged Top Lock Nut - 5/16"



**X** 1704931 Flanged Nylon Lock Nut - 5/16"



**Y** 1700419 Nylon Lock Nut - 5/16"

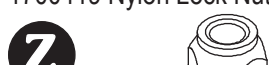

**Z** 1704297 Nylon Lock Nut - 5/16"



**AA** 1700407 Hex Nut - 3/8"



**BB** 1701580 Nylon Lock Nut - 3/8"

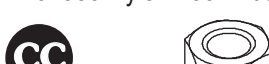

**CC** 1702668 Top Lock Nut - 3/8"



**DD** 1700436 Lock Washer - 1/4"



**EE** 1700427 Flat Washer - 1/4"

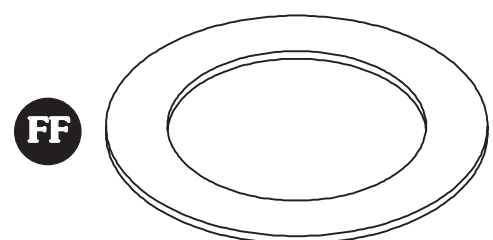

**FF** 1702890 Flat Washer - 1 1/4"



**GG** 1700428 Flat Washer - 5/16"



**HH** 1700434 Lock Washer - 3/8"



**JJ** 1700429 Flat Washer - 3/8"

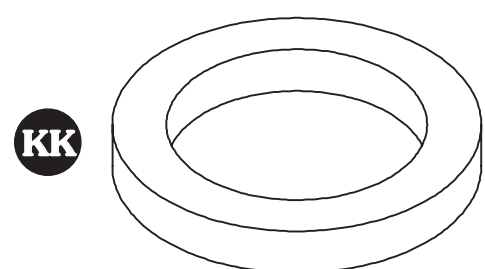

**KK** 1118318 Spacer Washer - 1/4" x 1.81"

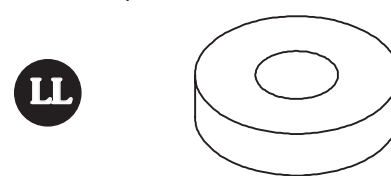

**LL** 1120291 Pivot Bracket Washer

**NOTE:** Read pages 2 and 3 entirely before drilling holes.

Determine if rivets are centered or off center on front and rear of trailer.

**FRONT OF TRAILER**

**STEP 1:** Locate front pivot mount bracket on driver side of trailer so center of pivot lies within shaded area shown below. Measure 41" down from top of cap or 43" from top of windshield.

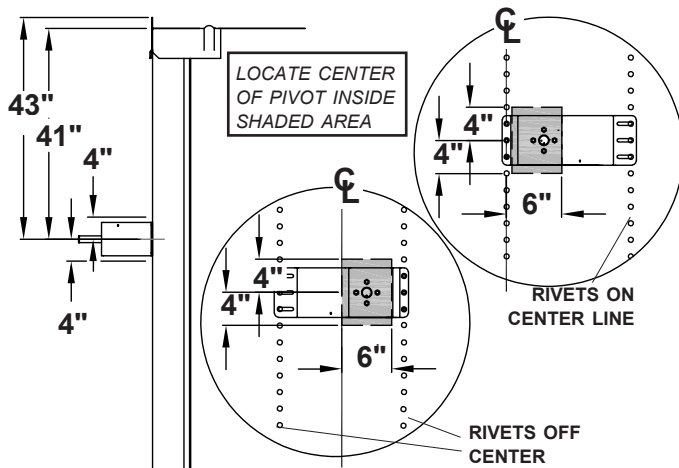

**REAR OF TRAILER**

**STEP 2:** Locate rear pivot mount bracket so center of pivot lies within shaded area shown below.

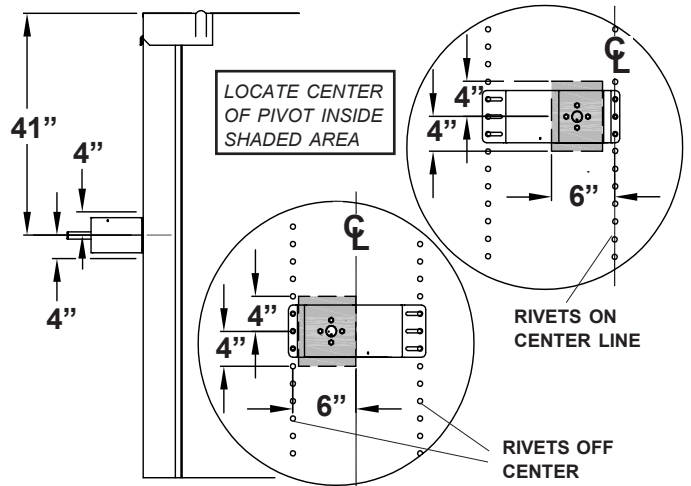

**NOTE:** Mount brackets into support braces on trailer, if possible. If bracket cannot be mounted into support braces, reinforce mounting area with backer plate for adequate support. Before drilling any holes, make sure flex arm has clear pathway to operate.

**INSTALL BRACKETS ON HORIZONTALLY CORRUGATED TRAILERS**

**NOTE:** Use pivot bracket washers **II** only when horizontal corrugation on trailer skin prevents bracket from contacting trailer skin.

**STEP 1:** If installing pivot bracket or pivot mount bracket on horizontally corrugated trailer skin, use brackets as guide to mark hole locations. Mark and drill 13/32" holes in trailer and fasten with screws **P**, flat washers **JJ**, lock washers **HH**, pivot bracket washers **II** and nuts **AA**. Locate pivot bracket washers between pivot bracket and trailer skin as shown.

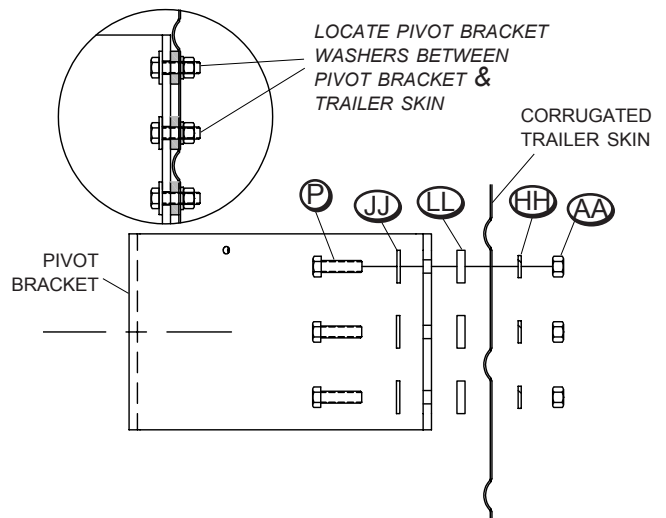

**STEP 3:** Place pivot mount brackets on trailer as shown below. Using brackets as guide, mark mounting hole locations.

**FRONT OF TRAILER**

**RIVETS/CORRUGATION ON CENTER**

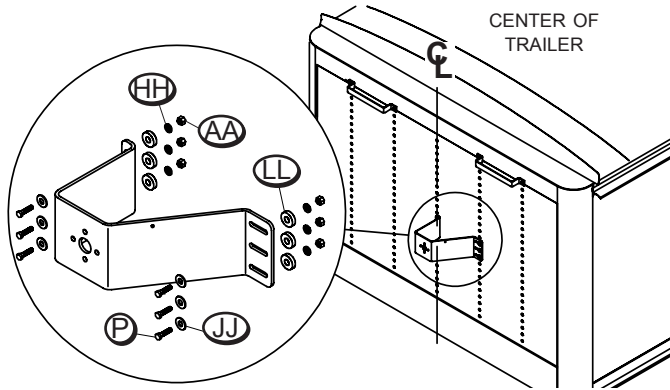

**RIVETS/CORRUGATION OFF CENTER**

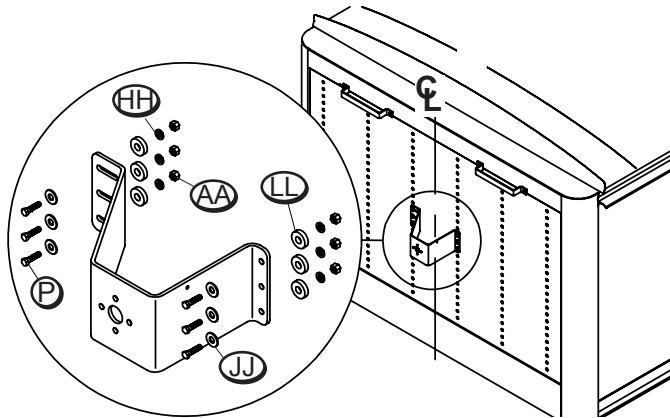

**REAR OF TRAILER**

**RIVETS/CORRUGATION ON CENTER**

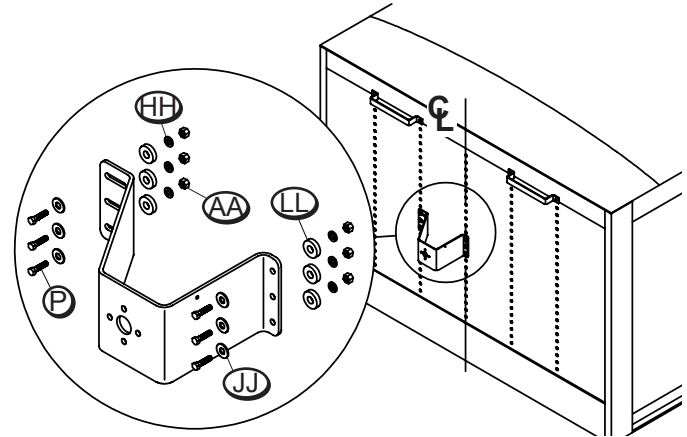

**RIVETS/CORRUGATION OFF CENTER**

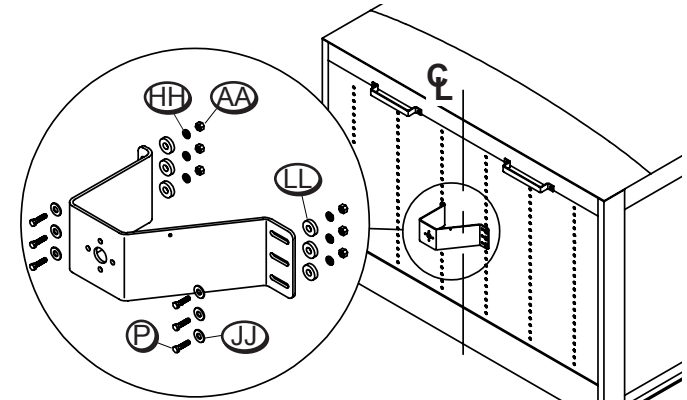

**STEP 4:** Remove rivets and mount brackets into rivet holes. If not possible, drill 13/32" holes in trailer. Fasten with screws **P**, flat washers **JJ**, lock washers **HH**, pivot bracket washers **LL** and nuts **AA**.



**NOTE:** Read entire page before drilling holes. Determine if rivets are centered or off center on front and rear of trailer.

**NOTE:** Use pivot bracket washers **(I)** only when horizontal corrugation on trailer skin prevents bracket from contacting trailer skin (see instructions on page 2).

**FRONT OF TRAILER**

**STEP 1:** Locate sloped pivot mount bracket 41" down from top of cap or 43" from top of windshield, measuring vertically as shown. Do not measure along slope of trailer.

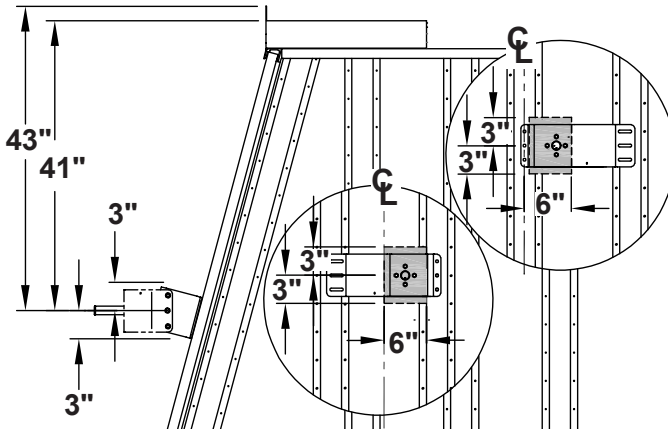

**REAR OF TRAILER**

**STEP 2:** Locate sloped pivot mount bracket 41" below top of cap, measuring vertically as shown. Do not measure along slope of trailer.

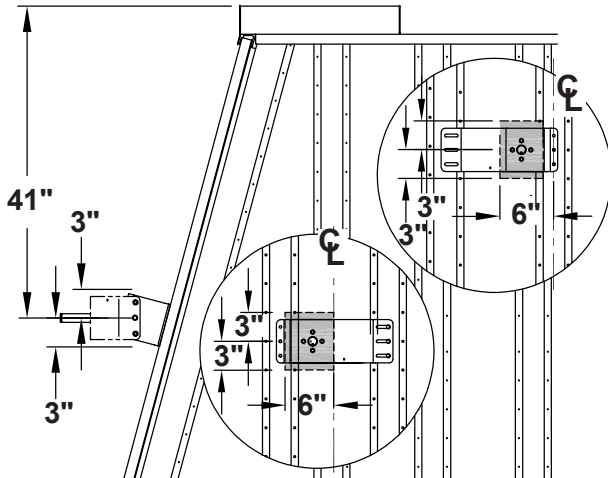

**NOTE:** Mount brackets into support braces on trailer, if possible. If bracket cannot be mounted into support braces, reinforce mounting area with backer plate for adequate support. If bracket does not sit flush with skin of trailer, install spacers between mounting bracket and skin of trailer to assure solid contact through support braces or backer plate. Before drilling any holes, make sure flex arm has clear pathway to operate.

**STEP 3:** Place pivot mount brackets on trailer as shown below. Using brackets as guide, mark mounting hole locations.

**FRONT OF TRAILER**

**RIVETS/CORRUGATION ON CENTER**

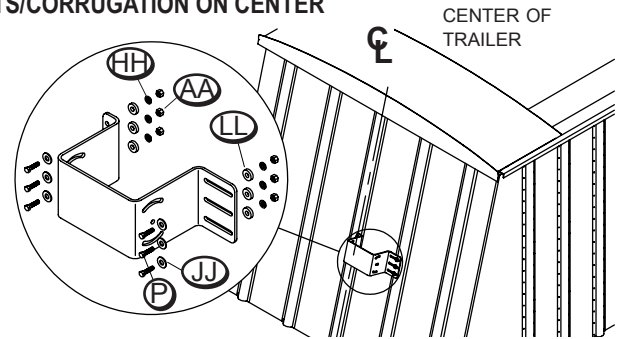

**RIVETS/CORRUGATION OFF CENTER**

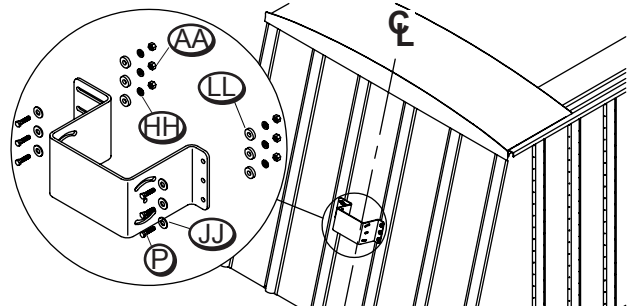

**REAR OF TRAILER**

**RIVETS/CORRUGATION ON CENTER**

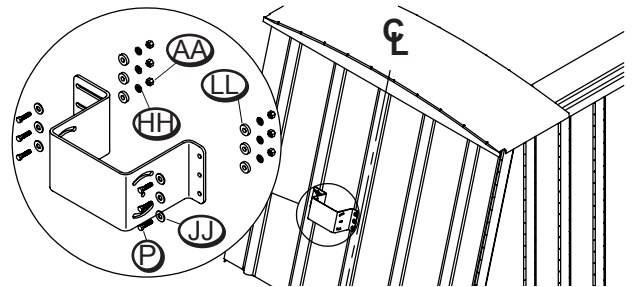

**RIVETS/CORRUGATION OFF CENTER**

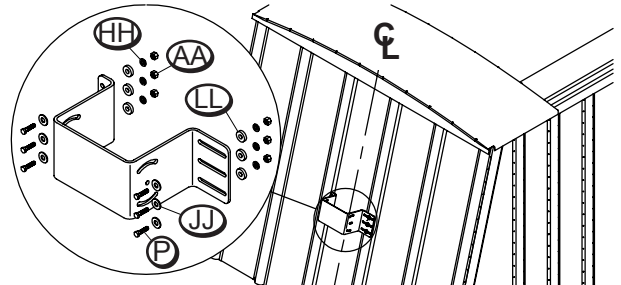

**STEP 4:** Drill 13/32" holes in trailer. Fasten sloped pivot mount bracket to trailer with screws **(P)**, flat washers **(JJ)**, lock washers **(HH)** and nuts **(AA)**.

**STEP 5:** Place pivot brackets on pivot mount brackets as shown below. Fasten pivot brackets to pivot mount brackets with screws **P**, flat washers **JJ**, lock washers **HH** and nuts **AA**.

**FRONT OF TRAILER**

RIVETS/CORRUGATION ON CENTER

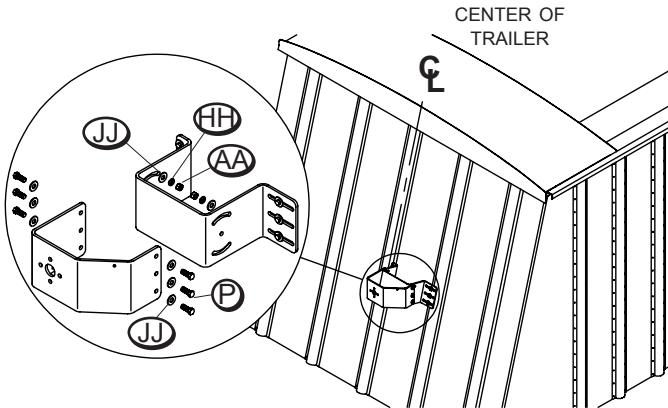

RIVETS/CORRUGATION OFF CENTER

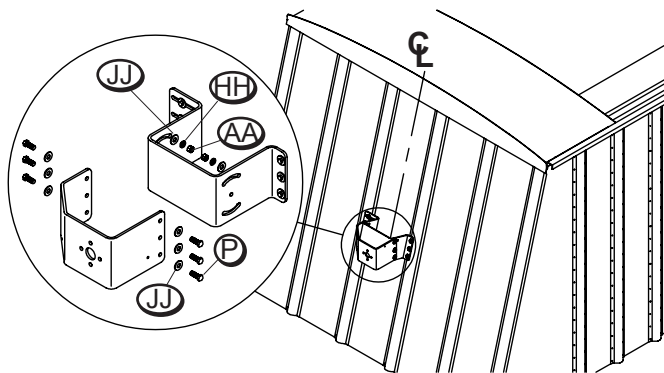

**REAR OF TRAILER**

RIVETS/CORRUGATION ON CENTER

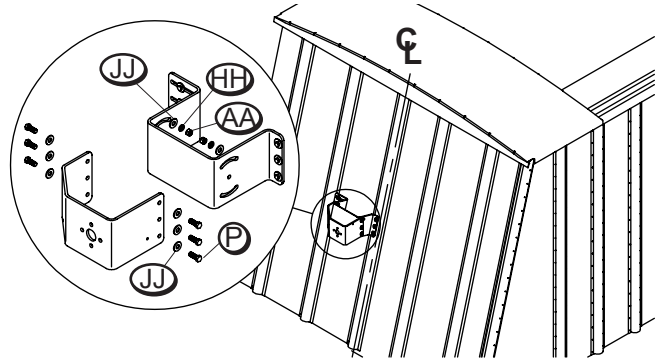

RIVETS/CORRUGATION OFF CENTER

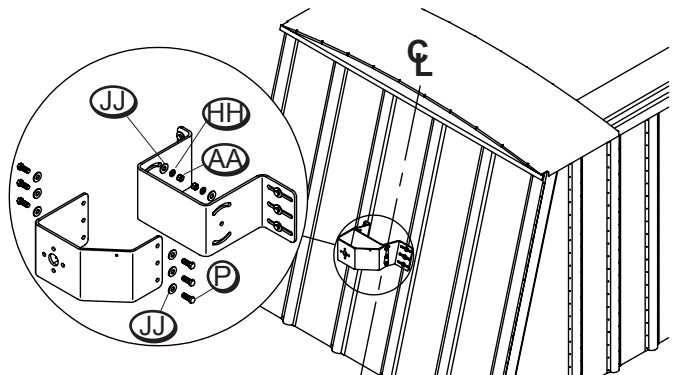



Item	Part #	Description
1.	1116920	Pivot Pin - 4 Spring
2.	1120361	Pivot Backer Plate - 5" x 16"
	1120418	Pivot Backer Plate - 5" x 20"
3.	1121993	Sloped Pivot Mt. Bracket - 6" Standoff - 6" Wide
	1121994	Sloped Pivot Mt. Bracket - 8" Standoff - 6" Wide
4.	1121992	Pivot Bracket - Sloped - 6" Wide
5.	1116919	Vertical Pivot Mount Bracket - 7-1/4" Standoff
	1117031	Vertical Pivot Mount Bracket - 9-1/4" Standoff
N.	1700400	Self-Tapping Screw - 3/8" x 1"
P.	1702891	Cap Screw - 3/8" x 1-1/4"
AA.	1700407	Hex Nut - 3/8"
HH.	1700434	Lock Washer - 3/8"
JJ.	1700429	Flat Washer - 3/8"
LL.	1120291	Pivot Bracket Washer

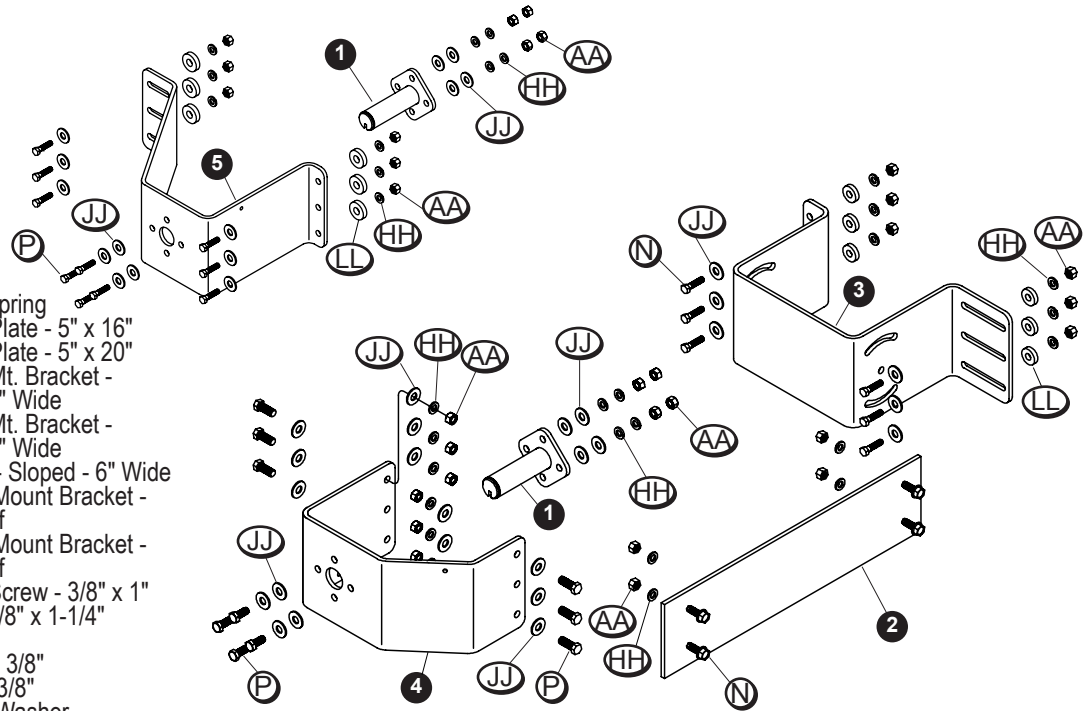

**STEP 1:** Align and loosely fasten pivot bracket to pivot mount bracket with screws **P**, lock washers **HH**, flat washers **JJ** and nuts **AA**.

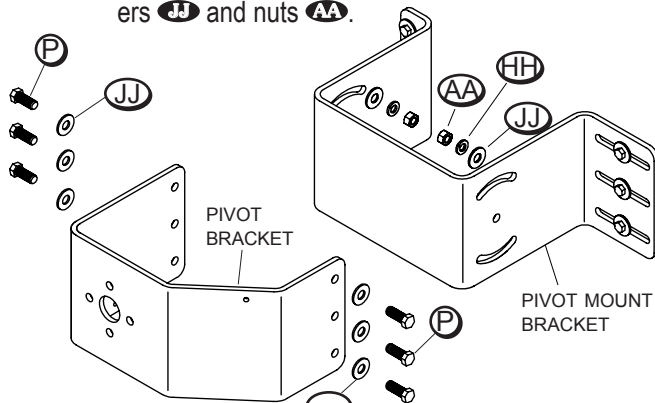

**STEP 2:** Align face of pivot bracket vertically and align pivot pin parallel with top rail of trailer, then tighten screws.

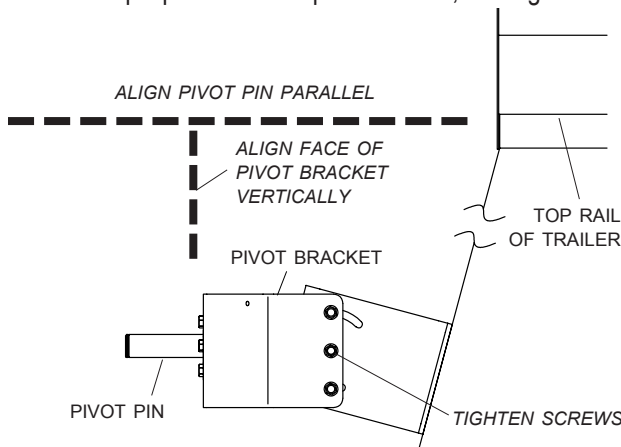

**STEP 3:** Fasten pivot pins to pivot brackets.

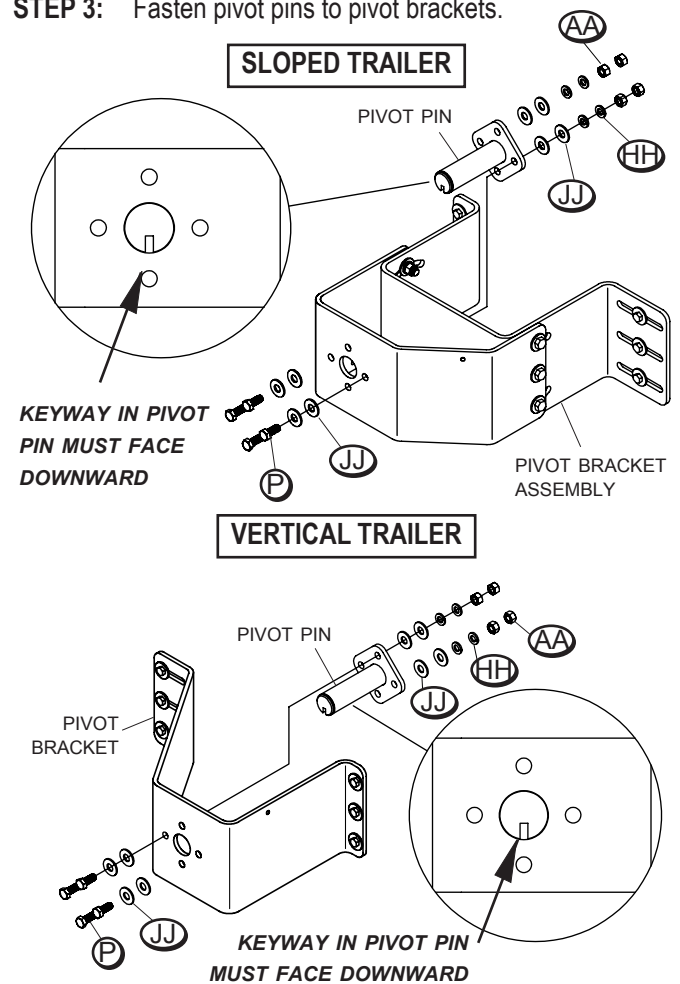

Item	Part #	Description
1.	1111027	Spiral Torsion Spring
2.	1702888	External Retaining Ring - 1-1/4"
3.	1704987	SMARTwire™ - 6 Ga. Plug x 1/4" Terminal x 10'9"
4.	1704751	Harness Lock Pin - 1/4" x 7/8"
5.	1702108	Wire Clip - 3/4" ID
6.	1121414	Bellow Plate - Square Holes
7.	1121413	Bellow Plate - Round Holes
8.	1704893	Cap Plug w/Holes
E.	1700403	Self-Tapping Screw - 1/4" x 3/4"
F.	1700398	Self-Drilling Screw - 1/4" x 3/4"
L.	1701455	Carriage Bolt - 5/16" x 2-1/2"
V.	1700408	Hex Nut - 1/4"
AA.	1704931	Flanged Nylon Lock Nut - 5/16"
DD.	1700436	Lock Washer - 1/4"
EE.	1700427	Flat Washer - 1/4"
FF.	1702890	Flat Washer - 1 1/4"
KK.	1118318	Spacer Washer - 1/4" x 1.28"

**NOTE:** Do not remove cable tie from front flex arm and motor assembly until installation is complete. See step 9.

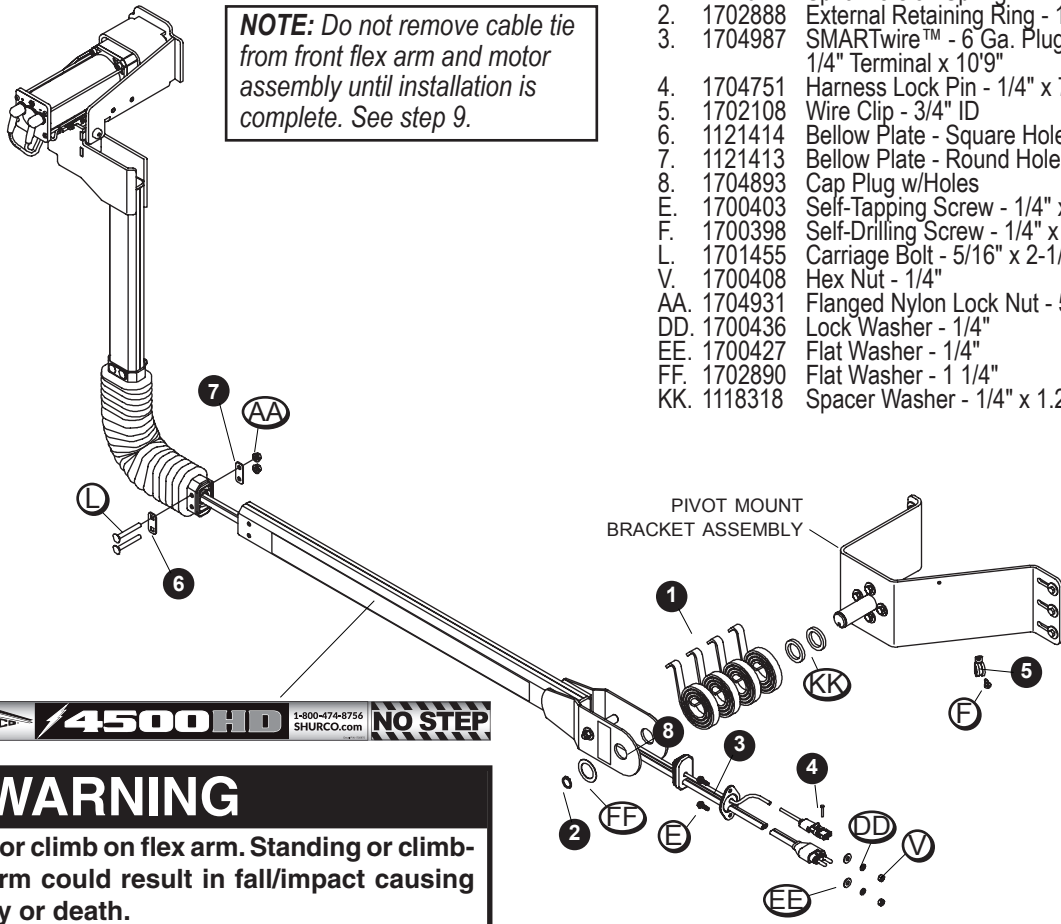

**WARNING**  
Do not stand or climb on flex arm. Standing or climbing on flex arm could result in fall/impact causing serious injury or death.

**STEP 1:** Assemble spacer washers (KK) onto pivot pin.

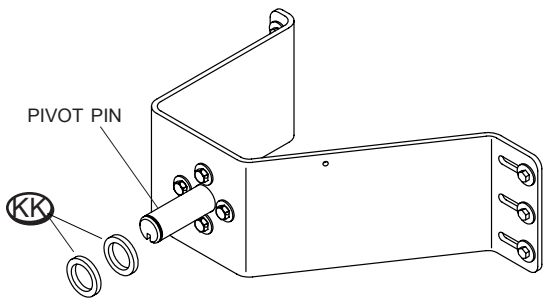

**STEP 2:** Align holes in bellow, end plates and bellow plates with holes in lower flex arm assembly as shown. Fasten with carriage bolts (L) and lock nuts (V).

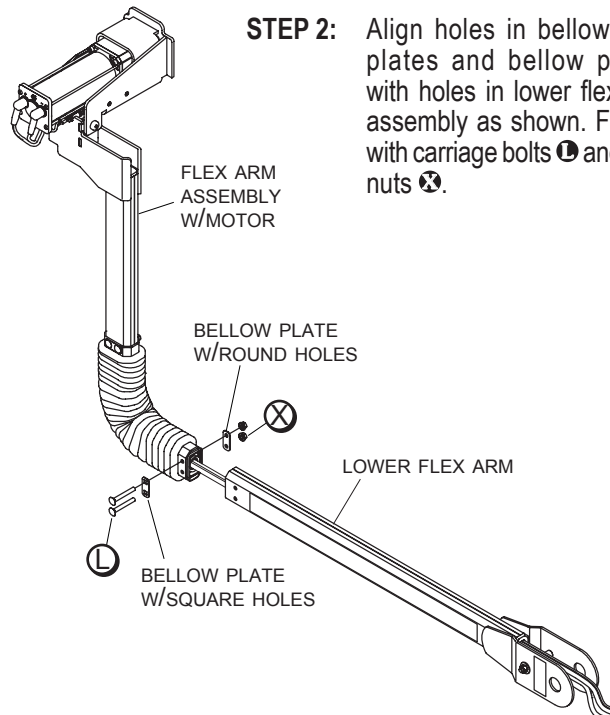

**STEP 3:** Assemble spiral torsion springs and lower flex arm onto pivot pin. Hook springs over spacer tube.

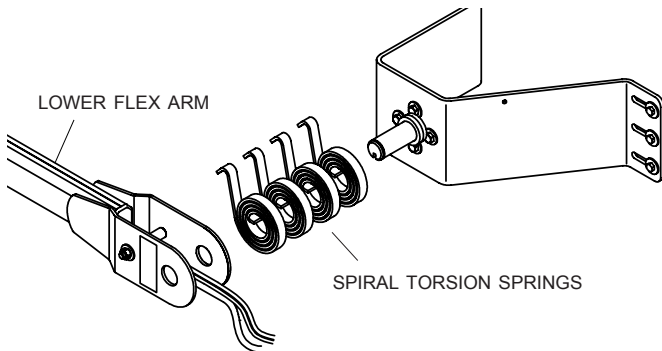

**STEP 4:** Secure with flat washer **FF** and retaining ring.

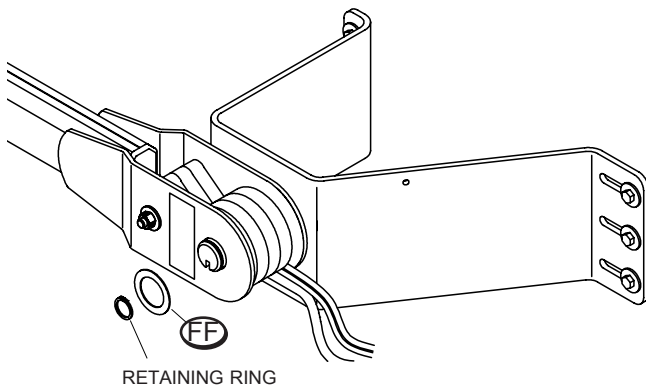

**NOTE:** Motor assembly on upper flex arm must face toward trailer as shown.

**STEP 5:** Route 6-ga. wire from flex arm through trailer skin. Fasten wire to pivot bracket with wire clip and self-drilling screw **F** in location shown.

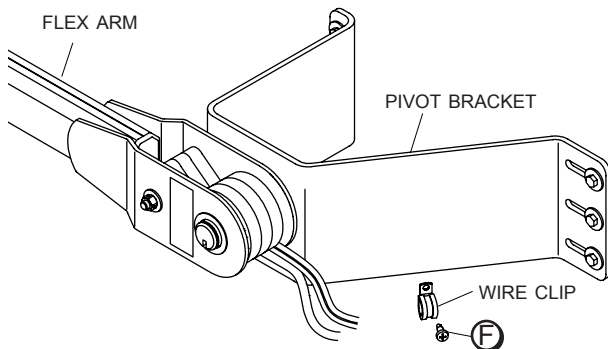

**NOTE:** Fasten wire clip with self-drilling screw on opposite side of pivot bracket from flex arm to prevent wire from being pinched during operation.

**NOTE:** Wire lengths are predetermined. Before installing SMARTwire™ components, review and confirm wire routing so wires reach components with ample room for connection.

**STEP 6:** Measure 11" horizontally from center line of trailer and 1" down from lower edge of pivot bracket. Mark and drill 1 1/2" hole through trailer skin.

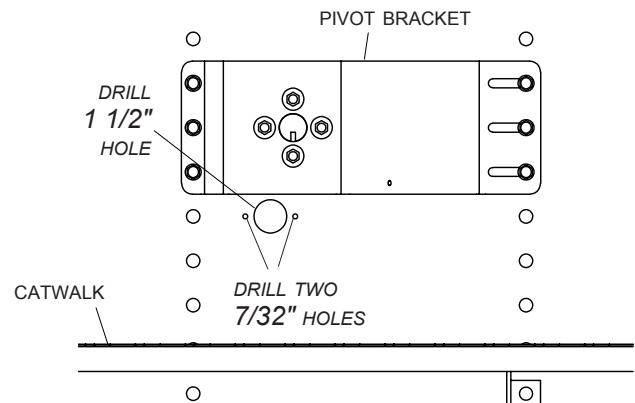

**STEP 7:** Align wire plate assembly with 1 1/2" hole. Using wiring hole as guide, mark and drill two 7/32" holes as shown.

**STEP 8:** Fasten wire plate assembly to front of trailer with screws **B**, lock washers **DD**, flat washers **EE** and nuts **T**.

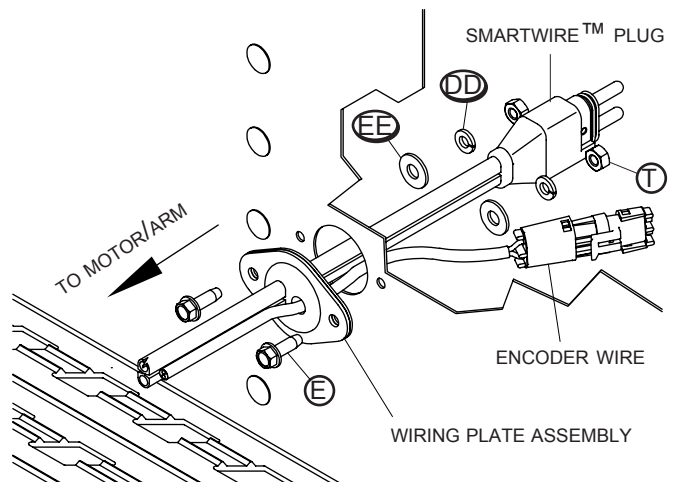

**STEP 9:** Remove cable tie from front arm/motor assembly before operating system.

Item	Part #	Description
1.	1704942	Rear Arm Bearing Ring
2.	1121430	Bearing Mount Box
3.	1704892	Cap Plug
4.	1121281	Upper Flex Arm - Bearing - RR
5.	1121413	Bellow Plate - Round Holes
6.	1121414	Bellow Plate - Square Holes
7.	1703873	Flex Arm Joint
8.	1704775	Bellow - HD Series Arm
9.	1704891	End Fitting
10.	1122000	Lower Flex Arm w/Warning Decals
11.	1702888	Retaining Ring - 1-1/4"
12.	1117033	Spacer Tube - .35" x 2-5/8"

Item	Part #	Description
13.	1111027	Spiral Torsion Spring
14.	1706103	Blind Rivet - 3/16"
L.	1701455	Carriage Bolt - 5/16" x 2-1/2"
S.	1704943	Shoulder Bolt - 3/8" x 2" - 5/16" x 1/2" Thd.
M.	1201022	Cap Screw - 5/16" x 3-1/2"
X.	1704931	Flanged Nylon Lock Nut - 5/16"
Y.	1700419	Nylon Lock Nut - 5/16"
FF.	1702890	Flat Washer - 1-1/4"
GG.	1700428	Flat Washer - 5/16"
KK.	1118318	Spacer Washer - 1/4" x 1.28"

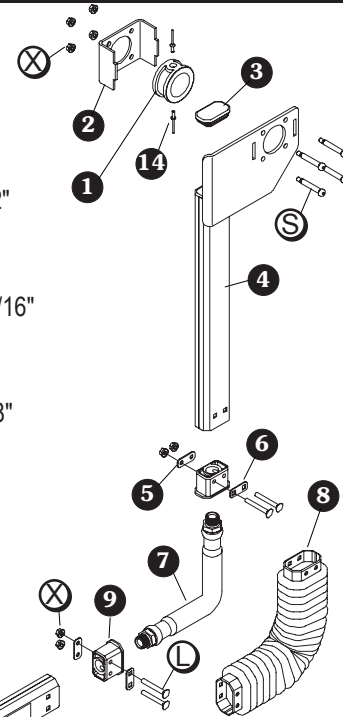

**⚠ WARNING**  
Do not stand or climb on flex arm. Standing or climbing on flex arm could result in fall/impact causing serious injury or death.

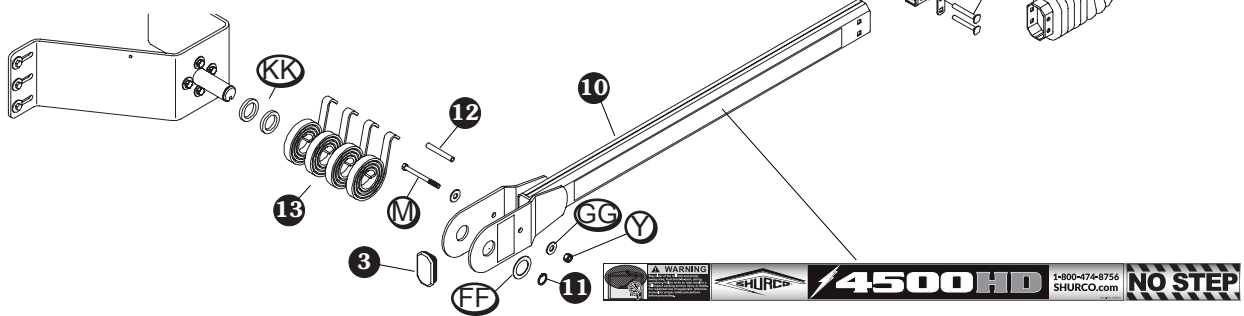

**STEP 1:** Install cap plug on lower flex arm. Fasten spacer tube into spring support bracket on lower flex arm with screw **M**, two flat washers **GG** and nylon lock nut **Y**.

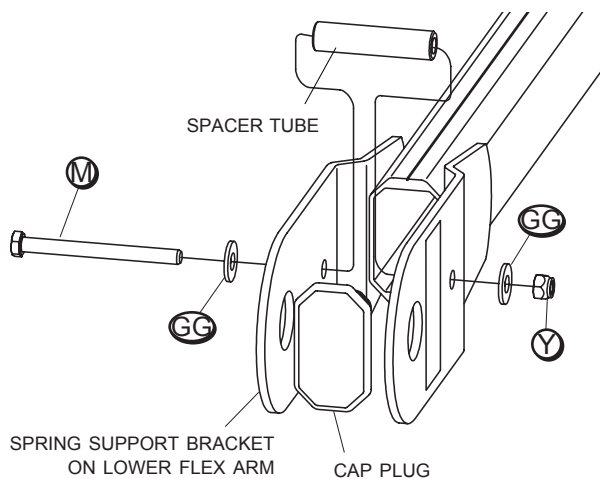

**NOTE:** Insert cap screw through flex arm so head of screw is on inside of assembly (towards trailer). Warning label must be in plain view on outside of assembly.

**STEP 2:** Install cap plug on rear upper flex arm.

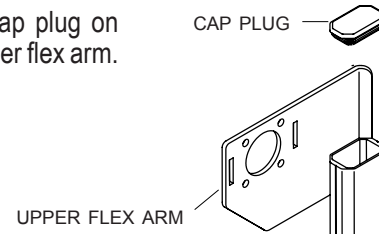

**STEP 3:** Thread end fittings onto both ends of flex arm joint. Tighten so end fittings are parallel.

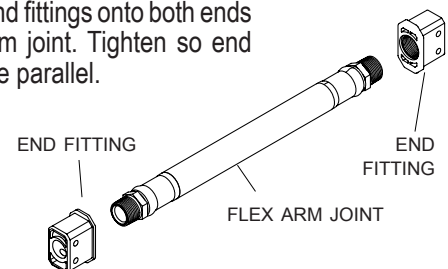

**⚠ WARNING**  
Flex arms are under tension while torsion springs are engaged. Use caution while assembling and disassembling arms. Failure to read and follow instructions could result in serious injury or death.

**STEP 4:** Insert flex arm joint into upper flex arm and slide bellow over flex arm joint. Align holes in upper flex arm, bellow plates, flex arm joint and bellow. Fasten with carriage bolts **L** and lock nuts **X**.

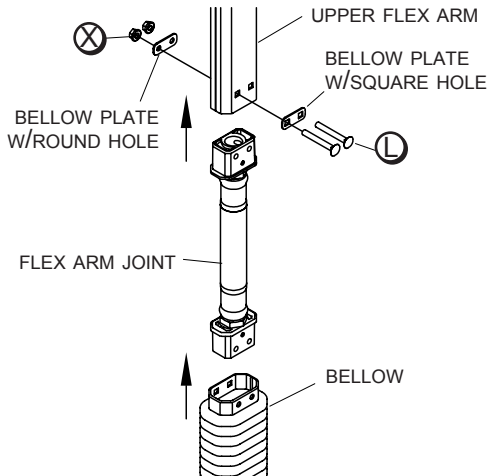

**STEP 5:** Insert lower end fitting into lower flex arm assembly with end of bellow over outside of arm. Align holes in lower flex arm assembly, bellow plates, end fitting and bellow. Fasten with carriage bolts **L** and lock nuts **X**.

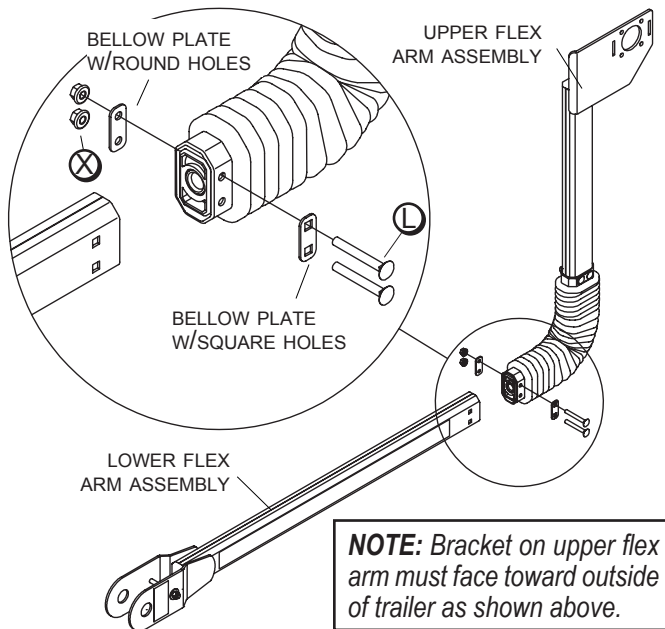

**STEP 6:** Assemble spacer washers **KK** onto pivot pin.

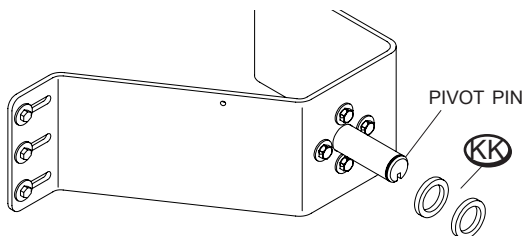

**STEP 7:** Assemble spiral torsion springs and lower flex arm onto pivot pin. Hook springs over spacer tube.

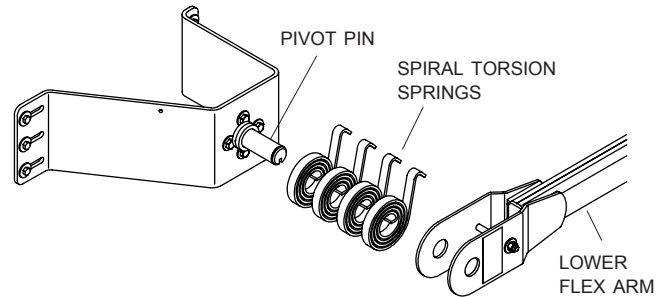

**STEP 8:** Secure with flat washer **FF** and retaining ring.

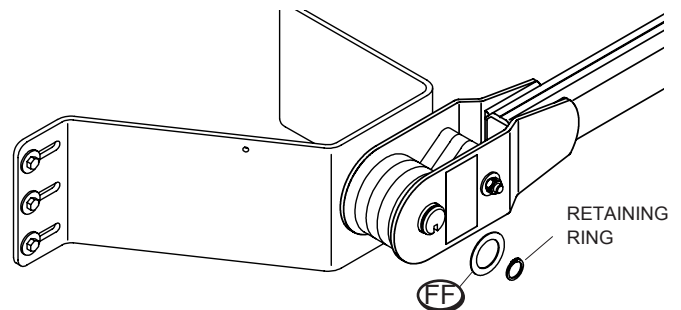

**STEP 9:** Roll tarp closed over box with roll tube hanging below latchplate. Remove crank assembly and U-clamps from roll tube.

**NOTE:** Remove any existing returns. Do not leave unattended until flex arm is securely fastened to roll tube.

**STEP 10:** Insert roll tube through bearing mount box, bearing ring and upper flex arm bearing plate, aligning end of splined shaft 5" past bearing plate as shown. Fasten with shoulder bolts **S** and nuts **X** as shown, anchoring bearing ring between bolts.

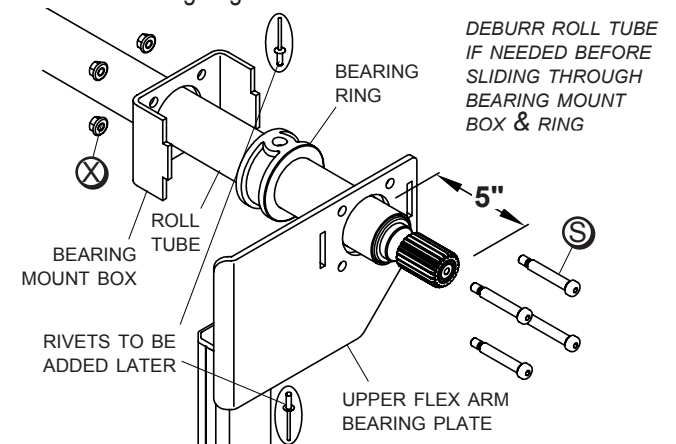



Item	Part #	Description
1.	1705160	Rear Arm Bearing Ring - 3"
2.	1123248	Bearing Mount Box - 3"
3.	1704892	Cap Plug
4.	1124958	Upper Flex Arm - Bearing - 3" - RR
5.	1121413	Bellow Plate - Round Holes
6.	1121414	Bellow Plate - Square Holes
7.	1703873	Flex Arm Joint
8.	1704775	Bellow - HD Series Arm
9.	1704891	End Fitting
10.	1121999	Lower Flex Arm w/Warning Decals
11.	1702888	Retaining Ring - 1-1/4"

Item	Part #	Description
12.	1117033	Spacer Tube - .35" x 2-5/8"
13.	1111027	Spiral Torsion Spring
14.	1706103	Blind Rivet - 3/16"
L.	1701455	Carriage Bolt - 5/16" x 2-1/2"
S.	1704943	Shoulder Bolt - 3/8" x 2" - 5/16" x 1/2" Thd.
M.	1201022	Cap Screw - 5/16" x 3-1/2"
X.	1704931	Flanged Nylon Lock Nut - 5/16"
Y.	1700419	Nylon Lock Nut - 5/16"
FF.	1702890	Flat Washer - 1-1/4"
GG.	1700428	Flat Washer - 5/16"
KK.	1118318	Spacer Washer - 1/4" x 1.28"

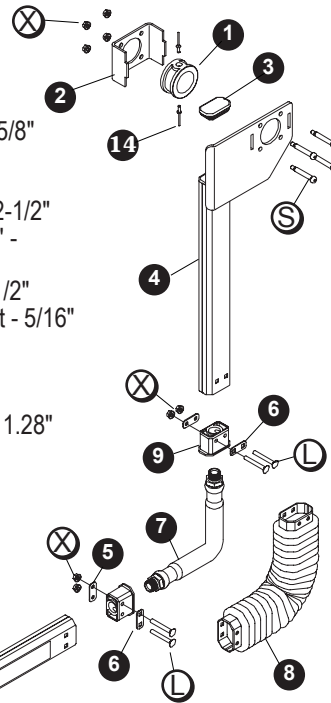

**WARNING**  
Do not stand or climb on flex arm. Standing or climbing on flex arm could result in fall/impact causing serious injury or death.

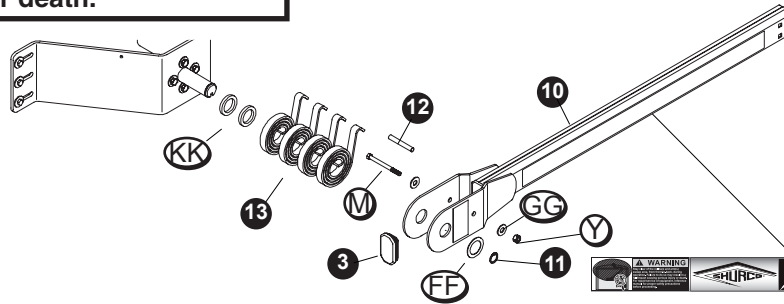

**STEP 1:** Install cap plug on lower flex arm. Fasten spacer tube into spring support bracket on lower flex arm with screw **M**, washers **GG** and nut **Y**.

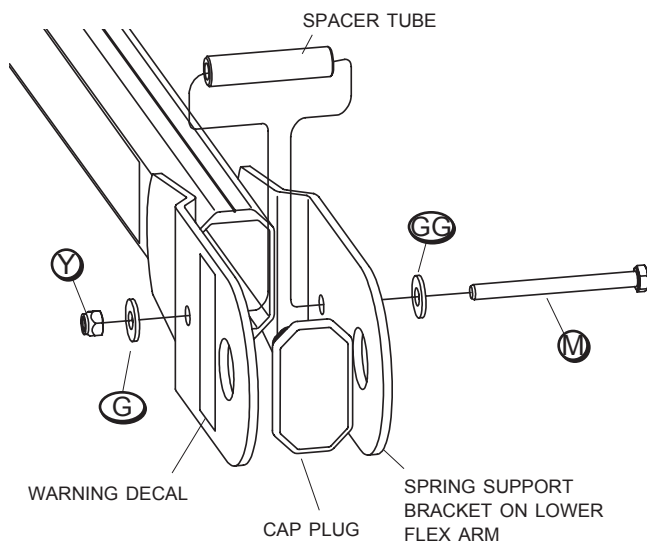

**NOTE:** Insert cap screw through flex arm so head of screw is on inside of assembly (towards trailer). Warning label must be in plain view on outside of assembly.

**STEP 2:** Install cap plug on rear upper flex arm.

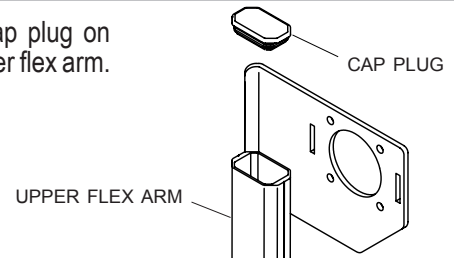

**STEP 3:** Fully thread end fittings onto both ends of flex arm joint. Tighten so end fittings are parallel.

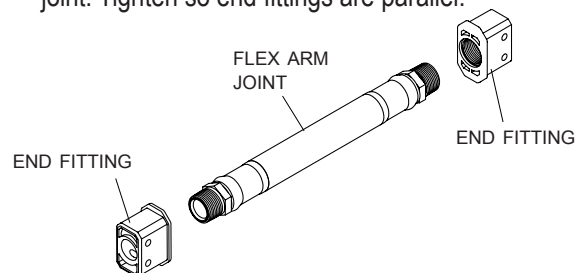

**WARNING**  
Flex arms are under tension while torsion springs are engaged. Use caution while assembling and disassembling arms. Failure to read and follow instructions could result in serious injury or death.



**STEP 4:** Insert flex arm joint into upper flex arm and slide bellow over flex arm joint. Align holes in upper flex arm, bellow plates, flex arm joint and bellow. Fasten with bolts **L** and flanged nuts **X**.

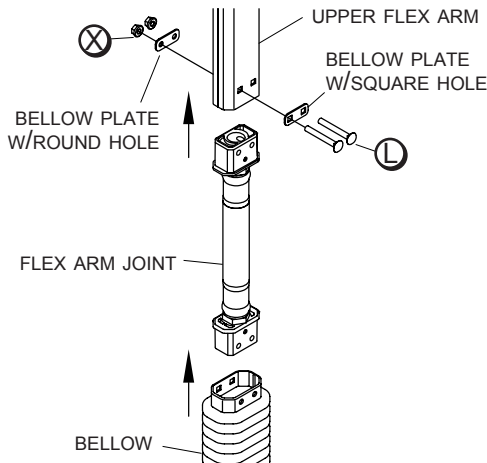

**STEP 5:** Insert lower end fitting into lower flex arm assembly with end of bellow over outside of arm. Align holes in lower flex arm assembly, bellow plates, end fitting and bellow. Fasten with bolts **L** and flanged nuts **X**.

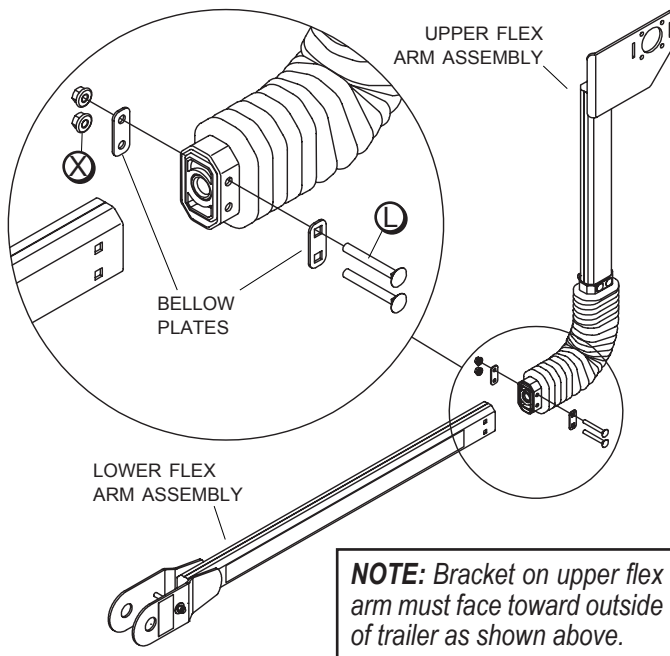

**STEP 6:** Assemble spacer washers **KK** onto pivot pin.

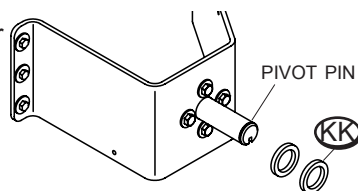

**STEP 7:** Assemble spiral torsion springs and lower flex arm onto pivot pin. Hook springs over spacer tube.

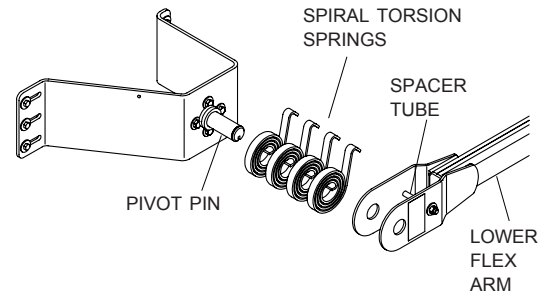

**STEP 8:** Secure with washer **FF** and retaining ring.

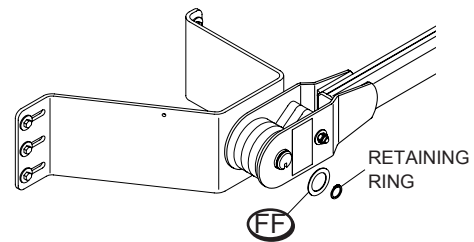

**STEP 9:** Roll tarp closed over box with roll tube hanging below latchplate. Remove crank assembly and U-clamps from roll tube.

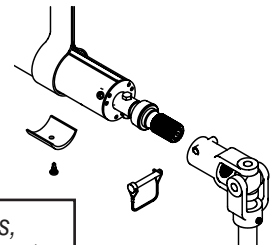

**NOTE:** Remove any existing returns, such as cable return, bungee return, etc. Do not leave unattended until flex arm is securely fastened to roll tube extension.

**STEP 10:** Insert roll tube through bearing mount box, bearing ring and upper flex arm bearing plate, aligning end of splined shaft 5" past bearing plate as shown. Fasten with bolts **S** and nuts **X** as shown, anchoring bearing ring between bolts.

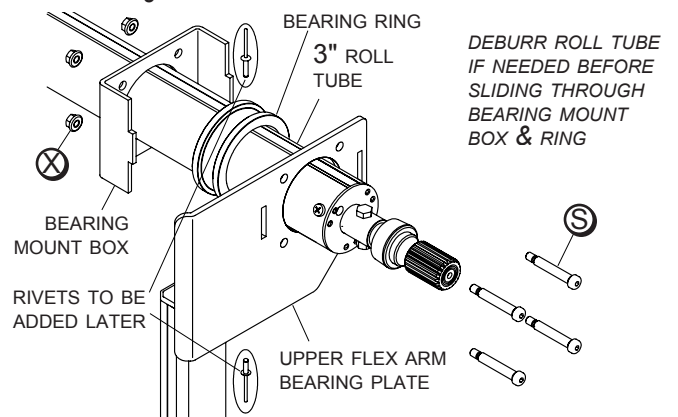

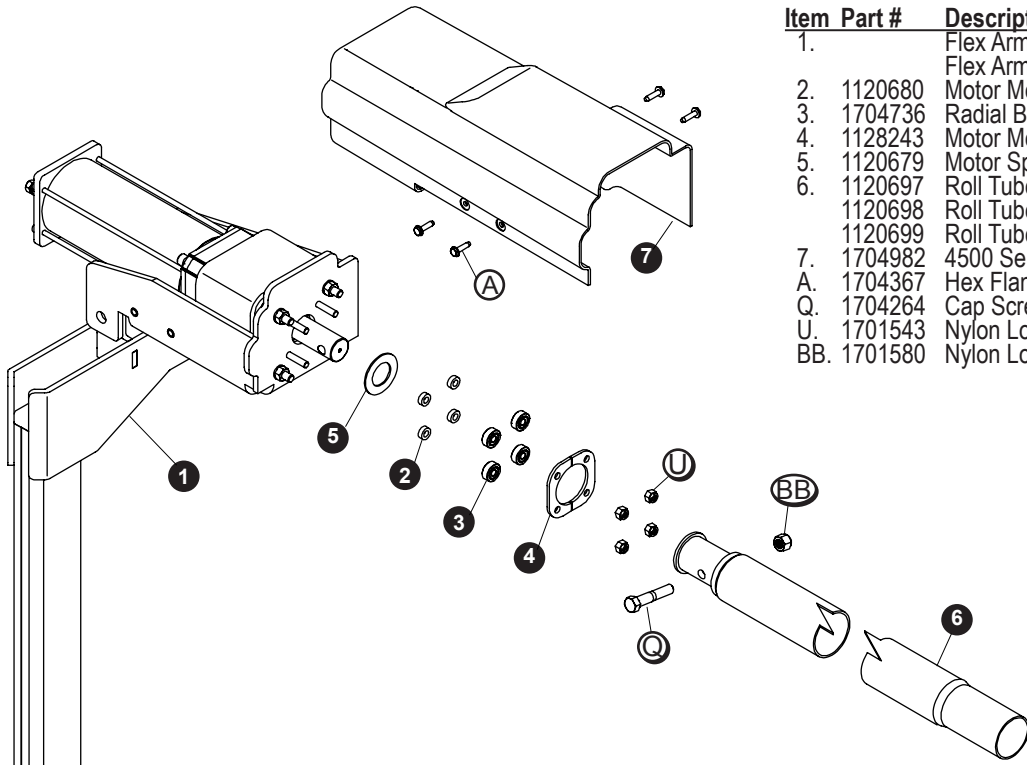

Item	Part #	Description
1.		Flex Arm Assembly w/Motor - Std. - RR
		Flex Arm Assembly w/Motor - 7-1/4" - RR
2.	1120680	Motor Mount Bearing Spacer
3.	1704736	Radial Ball Bearing - 1/4" x 3/4"
4.	1128243	Motor Mount Bearing Retainer
5.	1120679	Motor Spacer
6.	1120697	Roll Tube Extension w/Drive Shaft - 34.43"
	1120698	Roll Tube Extension w/Drive Shaft - 45.37"
	1120699	Roll Tube Extension w/Drive Shaft - 74.87"
7.	1704982	4500 Series Motor Cover - Black
A.	1704367	Hex Flange Cap Screw - #10 x 3/4"
Q.	1704264	Cap Screw - 3/8" x 2" - Grade 8
U.	1701543	Nylon Lock Nut - 1/4"
BB.	1701580	Nylon Lock Nut - 3/8"

**REAR OF TRAILER**

**STEP 1:** Adjust roll tube toward front or rear of trailer so rear flex arm lies on vertical plane parallel to face panel and perpendicular to roll tube extension. Mark roll tube where roll tube extension ends.

**VERTICAL TRAILER**

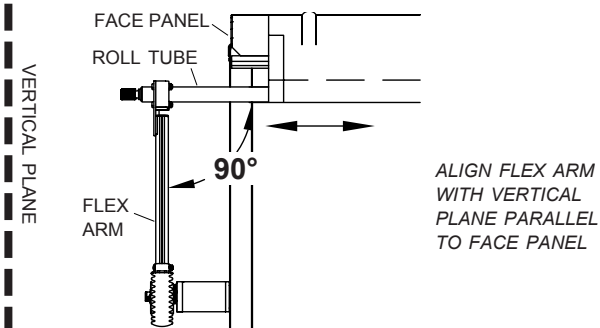

**SLOPED TRAILER**

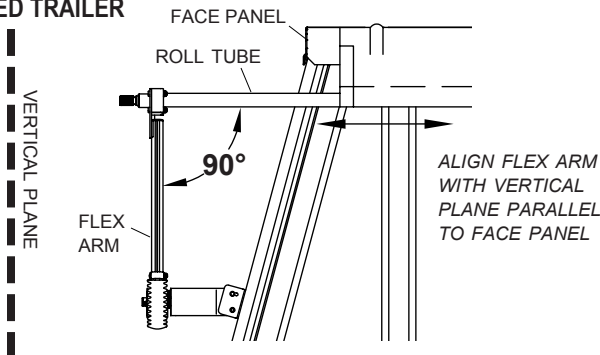

**FRONT OF TRAILER**

**STEP 2:** Slide tarp back on roll tube.

**VERTICAL TRAILER**

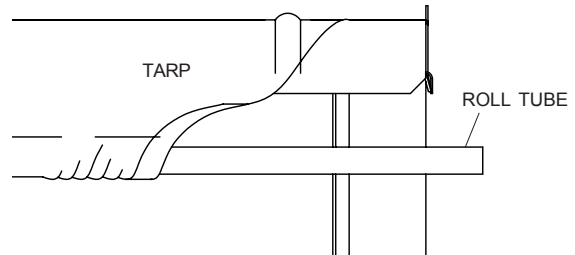

**SLOPED TRAILER**

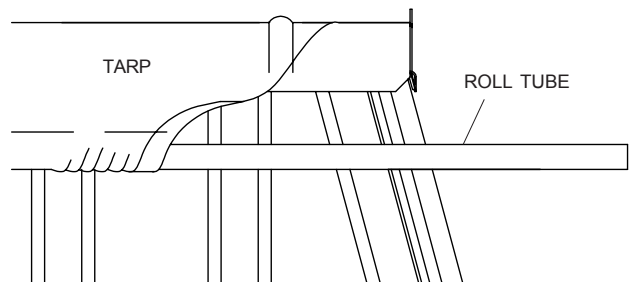

Fasten roll tube extension to motor mount bracket:

**STEP 3A:** Slide motor spacer over motor shaft.

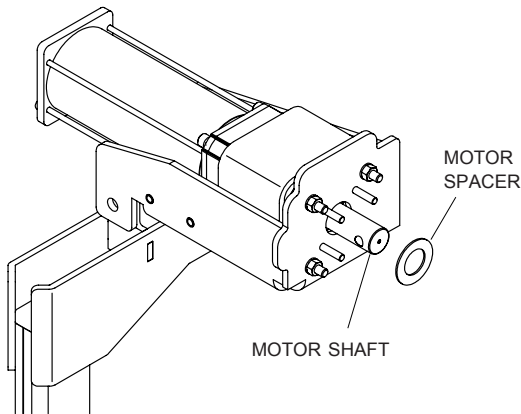

**STEP 3B:** Slide roll tube extension over motor shaft. Fasten with screws **Q** and lock nuts **BB**. Finger tighten only.

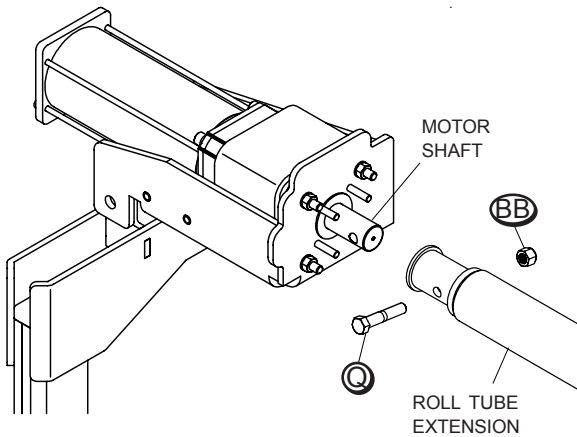

**STEP 4:** Hold flex arm with motor and roll tube extension in vertical plane to trailer and 90° to roll tube. Mark roll tube at location to be cut.

**NOTE:** Requires two people for safe installation.



**CAUTION**

On certain trailers, clearance lights might be in way of roll tube and can be damaged if caution is not taken. In some instances, a 'deflector' might have to be installed to prevent roll tube from causing damage to lights.

**VERTICAL TRAILER**

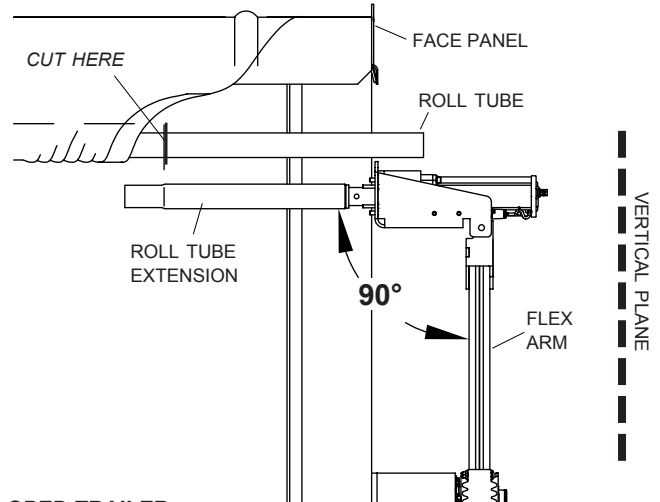

**SLOPED TRAILER**

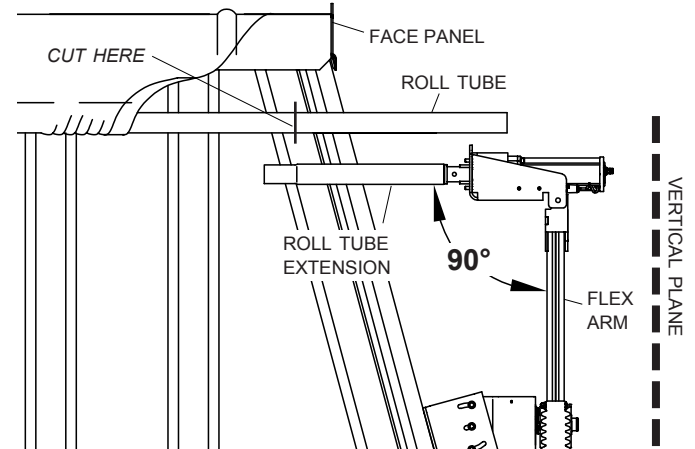

**STEP 5:** Reverse step 3B to unfasten and remove motor from roll tube extension. Remove roll tube extension from roll tube. Cut roll tube at marked location.

**STEP 6:** Insert swaged end of roll tube extension w/drive shaft into roll tube. Align extension straight with roll tube and weld all around. Grind smooth.

**NOTE:** Pull roll tube away from tarp and trailer before welding to protect from weld spatter. Align roll tube extension straight with roll tube before welding so tarp system will roll smoothly.

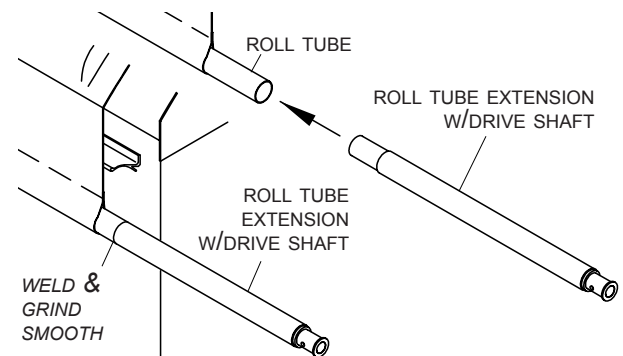

**NOTE:** To prevent rust, paint all exposed metal, such as weld seams and/or metal exposed by grinding or cutting, with corrosion-resistant paint.

**STEP 7:** Slide roll tube/roll tube extension weldment back into position and align upper flex arm on front of trailer. Follow step 8 to install motor, positioning motor as shown below. Make sure torsion springs load when tarp opens.

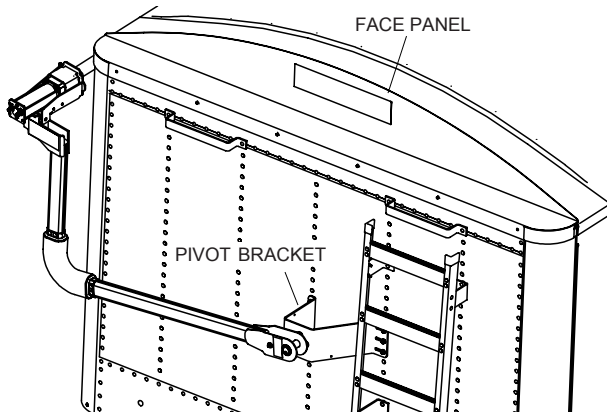

**WARNING**

Flex arms are under tension while torsion springs are engaged. Use caution while assembling and disassembling arms. Failure to read and follow instructions could result in serious injury or death.

**STEP 8:** Fasten and secure roll tube to electric motor shaft with screw (Q) and lock nut (BB). Install bearing spacers, radial ball bearings and bearing mount retainer and secure with nuts (U).

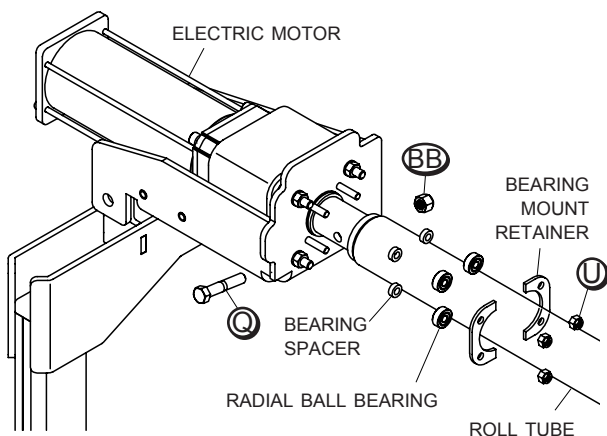

**NOTE:** Verify flex arm is on vertical plane and parallel to face panel before proceeding. Make sure all fasteners holding motor to upper flex arm bracket are tightened securely.

**STEP 9:** Fasten motor cover onto motor with screws (A).

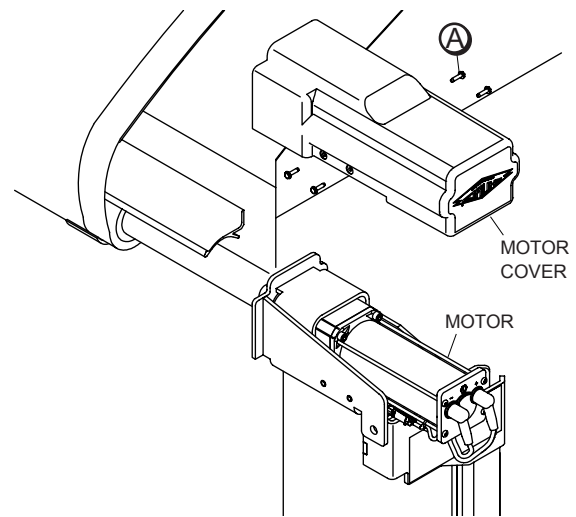

**STEP 10:** Adjust rear roll tube extension to align flex arm on vertical plane parallel to face panel. Do not drill holes and/or fasten until tarp and roll tube are in desired position.

**STEP 11:** When both front and rear flex arms are vertical, drill 3/16" holes and fasten bearing ring to roll tube with two rivets.

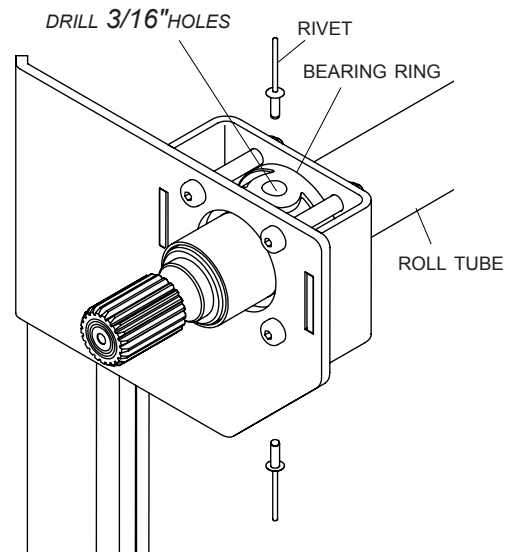

**STEP 12:** Fasten tarp to roll tube with existing U-clamps and screws. Tighten all fasteners securely. Tighten front and rear flex arm connections.

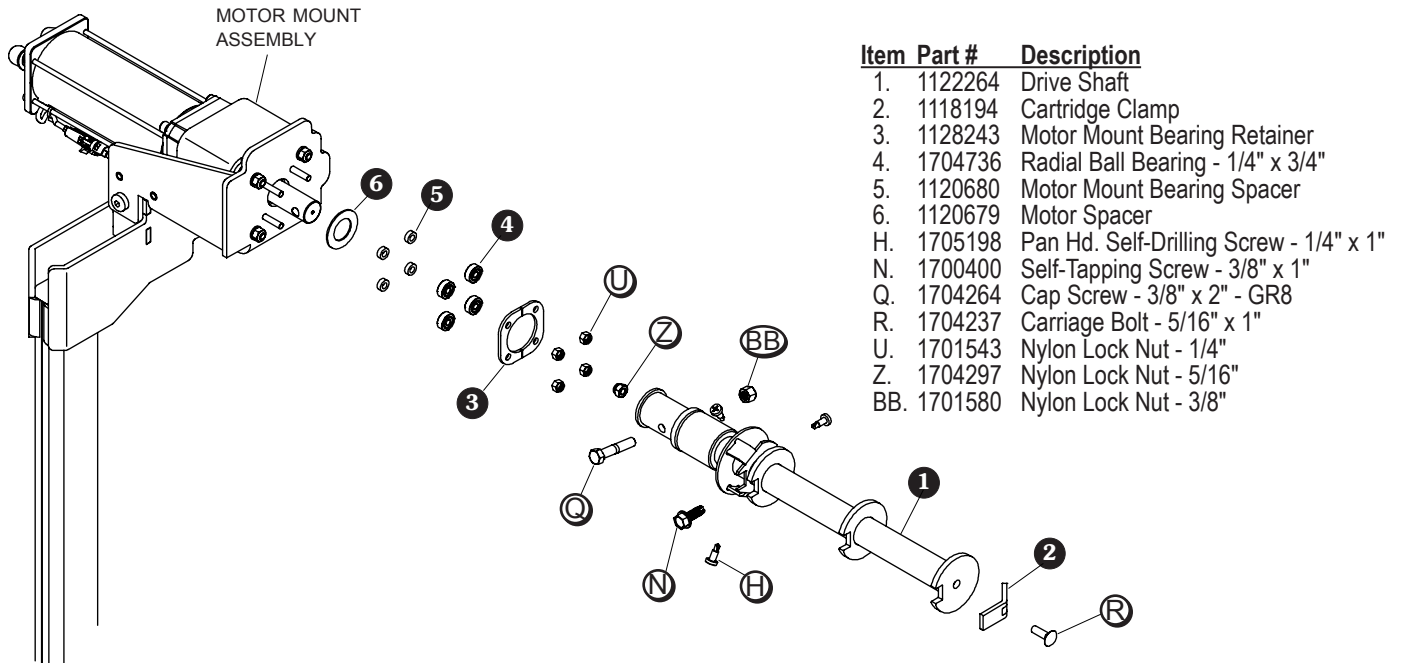

**STEP 1:** Loosely fasten cartridge clamp to drive shaft with screw **H** and lock nut **Z**. Insert drive shaft into roll tube as shown. To secure drive shaft to roll tube, tighten nut **Z** to 20 ft.-lbs.

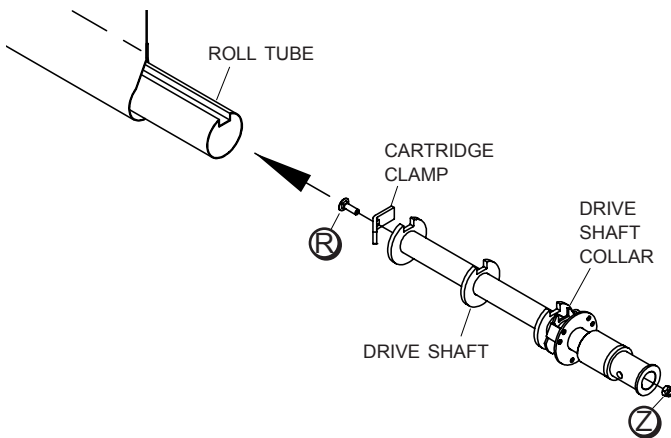

**STEP 2:** Install three screws **H** through roll tube and flats on drive shaft collar. Drill 5/16" hole between flats and collar, then fasten screw **N** through roll tube and drive shaft collar.

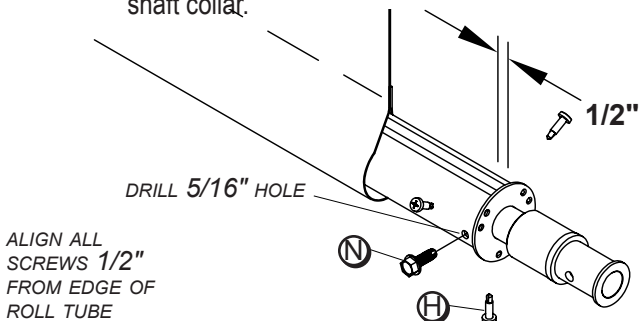

**STEP 3:** Slide motor spacer over motor shaft. Slide drive shaft over motor shaft. Fasten with screws **Q** and nuts **BB**. Finger tighten only.

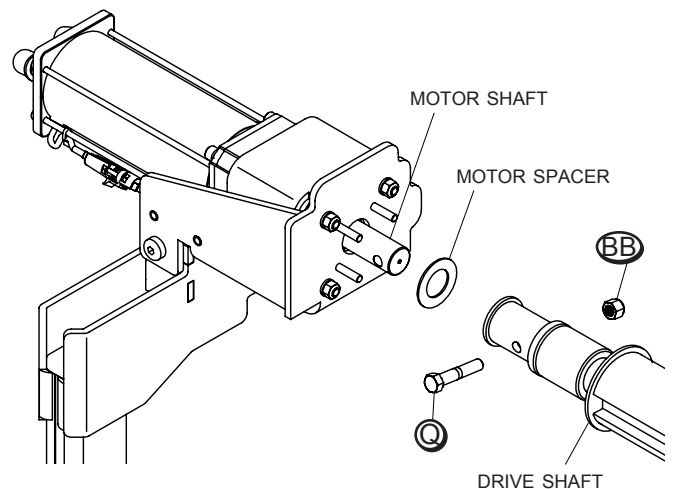

**CAUTION**  
If clearance lights are in path of roll tube, install deflector to prevent roll tube from damaging lights.

**WARNING**  
Flex arms are under tension while torsion springs are engaged. Use caution while assembling and disassembling arms. Failure to read and follow instructions could result in serious injury or death.

**STEP 4:** Fasten drive shaft to electric motor shaft with screw **(A)** and nut **(BB)**. Install bearing spacers, radial ball bearings and bearing mount retainer and secure with 1/4" lock nuts **(U)**.

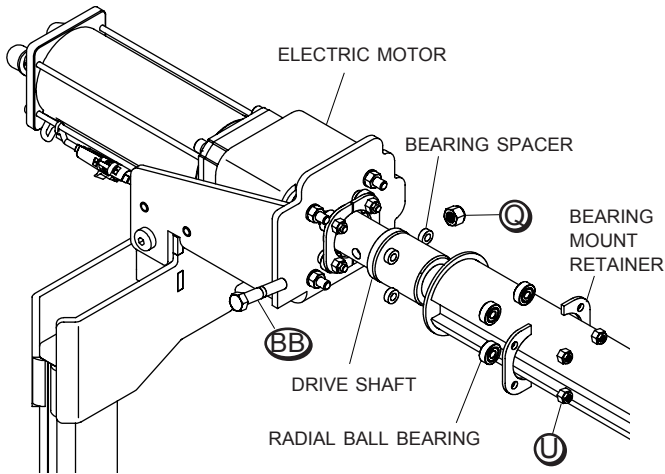

**NOTE:** Make sure all fasteners holding motor to upper flex arm bracket are tightened securely.



**CAUTION**

On certain trailers, clearance lights might be in way of roll tube and can be damaged if caution is not taken. In some instances, a 'deflector' might have to be installed to prevent roll tube from causing damage to lights.

**STEP 5:** Position motor as shown below. Make sure torsion springs load when tarp opens.

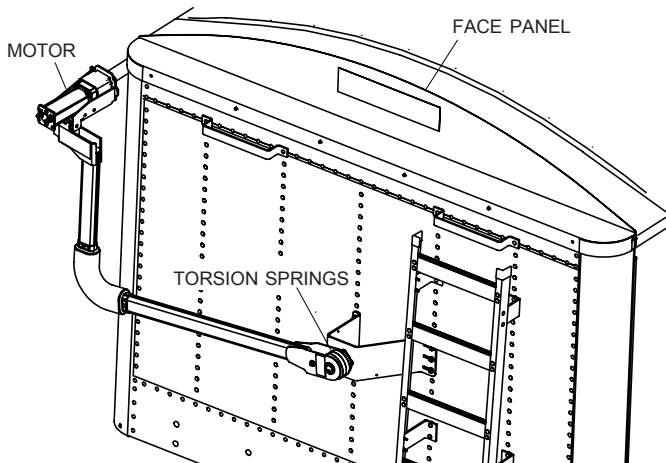

**STEP 6:** Align flex arm vertically with front of trailer and at 90° angle to roll tube.

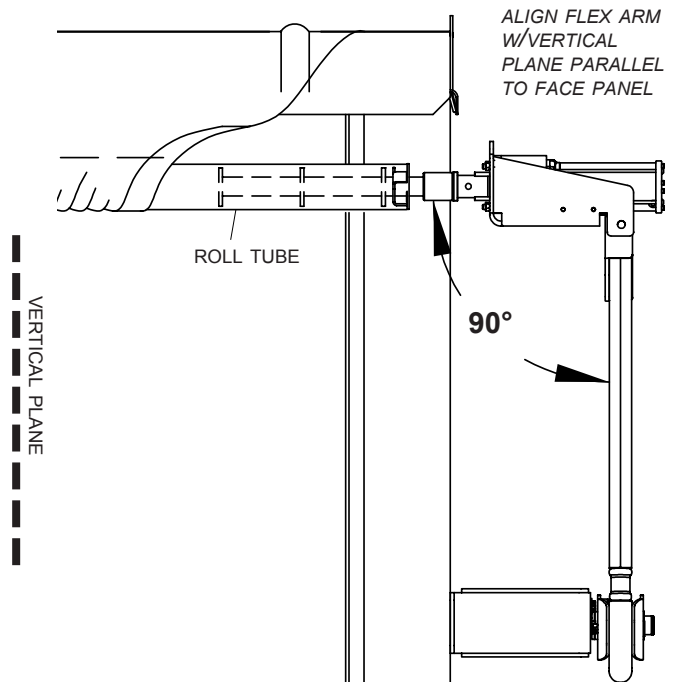

**STEP 7:** Fasten motor cover onto motor with screws **(A)**.

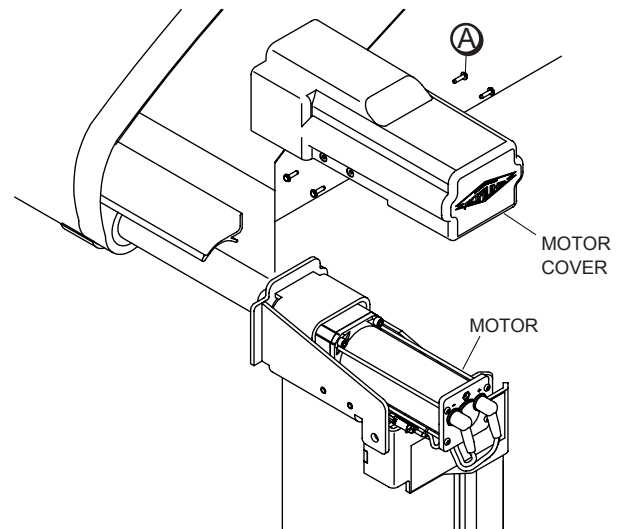



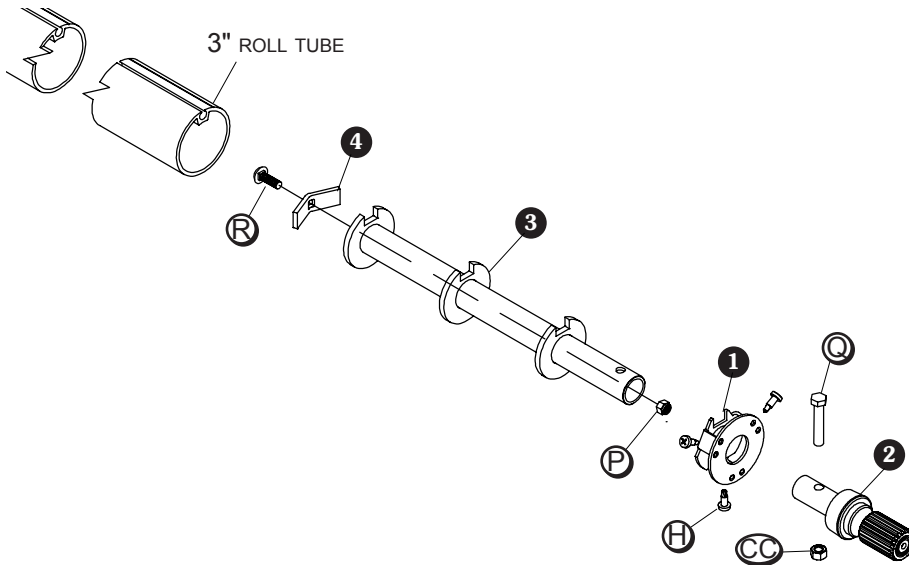

Item	Part #	Description
1.	1121040	Roll Tube Cap - 3" Spline
2.	1121111	Manual Crank Spline - 3" Tube
3.	1121039	Cartridge - 3" Spline End
4.	1118194	Cartridge Clamp
H.	1705198	Self-Drilling Screw - 1/4" x 1"
P.	1704297	Nylon Lock Nut - 5/16"
Q.	1704264	Cap Screw - 3/8" x 2"
R.	1704237	Carriage Bolt - 5/16" x 1"
CC.	1702668	Top Lock Nut - 3/8"

**STEP 1:** Assemble cartridge, nut P, clamp and carriage bolt R.

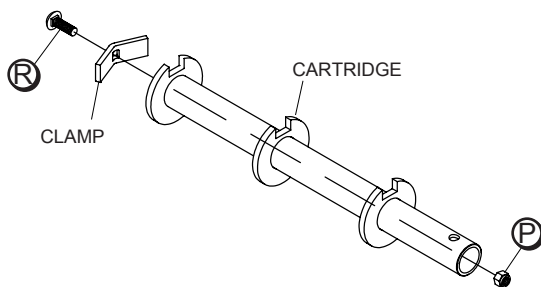

**STEP 2:** Insert cartridge assembly into roll tube. Position cartridge to extend 1-5/8" past end of roll tube. Tighten nut to 20 ft./lbs.

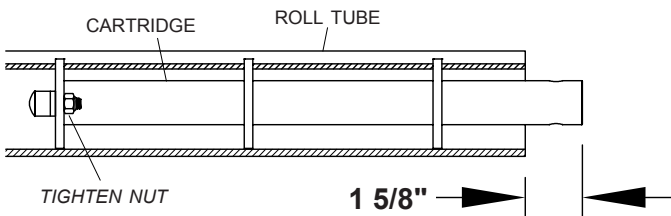

**STEP 3:** Insert cap into roll tube/cartridge assembly. Fasten three screws H through roll tube and flats on sides of cap.

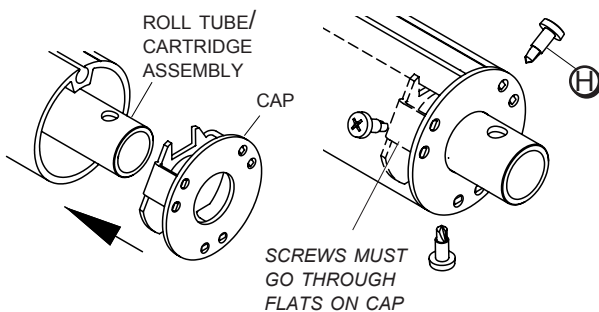

**STEP 4:** Insert manual crank spline into roll tube assembly. Secure with screw Q and nut CC.

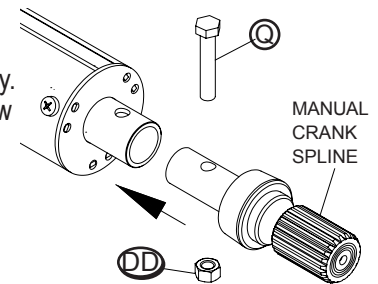

**STEP 5:** Adjust rear roll tube extension to align flex arm on vertical plane parallel to face panel. Do not drill holes and/or fasten until tarp and roll tube are in desired position.

**STEP 6:** When both front and rear flex arms are vertical, drill 3/16" holes and fasten bearing ring to roll tube with two rivets.

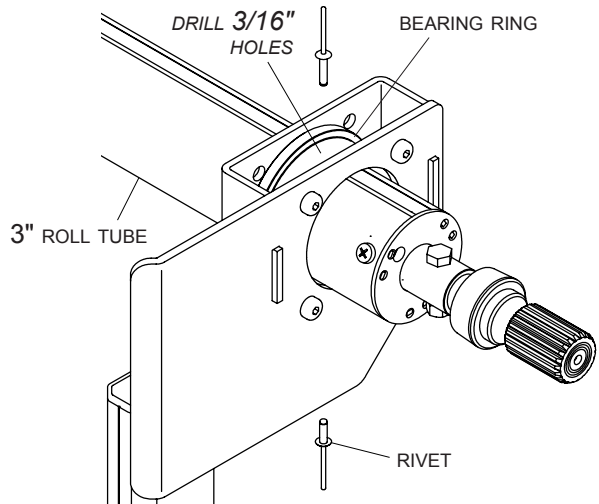

**STEP 7:** Fasten tarp to roll tube with existing U-clamps and screws. Tighten all fasteners securely. Tighten front and rear flex arm connections.

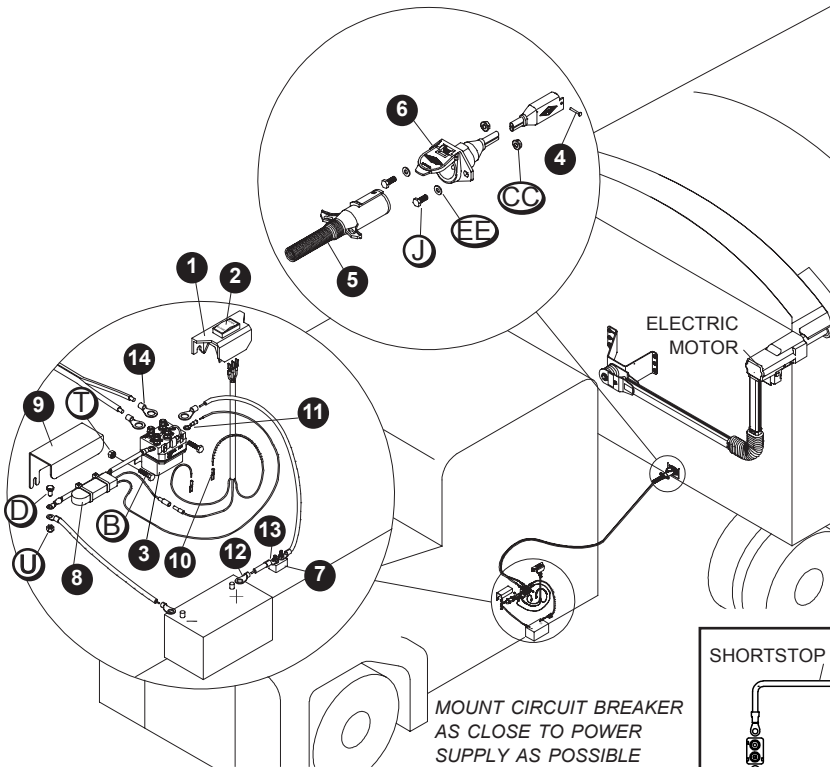

Item	Part #	Description
1.	1703661	Rocker Switch Mounting Bracket
2.	1116020	Rocker Switch
3.	1703845	Motor-Reversing Solenoid
4.	1704751	Harness Lock Pin - 1/4" x 7/8"
5.	1115385	Heavy-Duty Dual-Conductor Plug
6.	1120670	SMARTwire™ Dual-Conductor Socket
7.	1704354	40-Amp Modified-Reset Circuit Breaker
8.	1705624	50-Amp SMART Circuit Breaker
9.	1703896	Solenoid Cover
10.	1703659	Push-On Terminal - 14 Ga. 1/4"
11.	1704153	Ring Terminal - 14 Ga. x 1/4" Stud
12.	1703244	Ring Terminal - 6 Ga. x 3/8" Stud
13.	1703245	Ring Terminal - 6 Ga. x #10 Stud
14.	1702707	Ring Terminal - 6 Ga. 1/4" Stud
B.	1704905	Flanged Cap Screw - #10 x 1"
D.	1703959	Cap Screw - 1/4" x 3/4"
J.	1701045	Cap Screw - 5/16" x 3/4"
T.	1808844	Nylon Lock Nut - #10
U.	1701543	Nylon Lock Nut - 1/4"
CC.	1704946	Flanged Top Lock Nut - 5/16"
EE.	1700427	Flat Washer - 1/4"

**WARNING**  
 When transporting trailer, wiring from in-cab rocker switch must be connected to 4500 HD system on trailer. If motor is not connected to power while in transit, tarp may unwind and blow off.

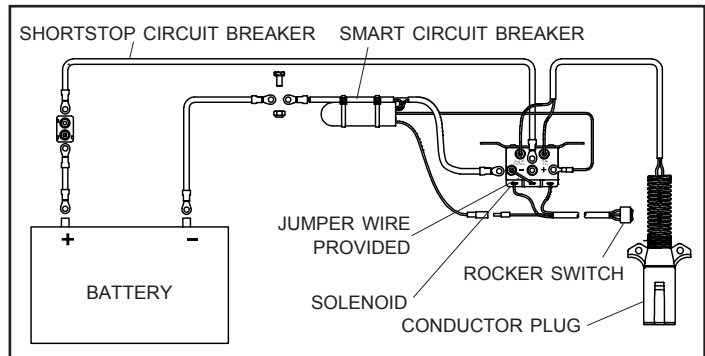

**STEP 1:** Mount solenoid in battery box or other location protected from elements and road debris. Solenoid posts should face up.

**STEP 2:** Assemble conductor plug. Unfasten screw and remove insert from plug housing. Feed 6-ga. dual wire through plug housing. Strip insulation back 1/2" and insert bare wire strands into brass contacts. Ensure there are no loose wire strands that could short circuit. Tighten set screws to secure wires. Replace insert into plug housing and secure screw.

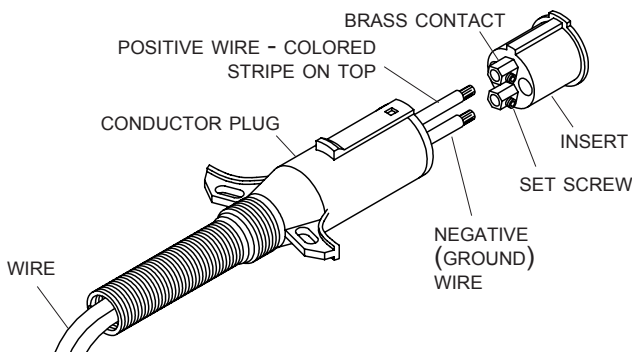

**STEP 3:** Route 6-ga. dual wire from conductor plug to solenoid and cut wire to length. Crimp and connect 1/4" ring terminals to rear two solenoid posts. Striped wire should be connected to right rear post. Orient wires so shield can be mounted over solenoid later.

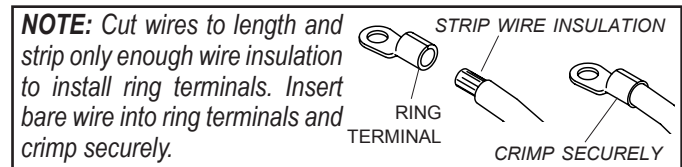

**STEP 4:** Connect SMART™ circuit breaker to solenoid.

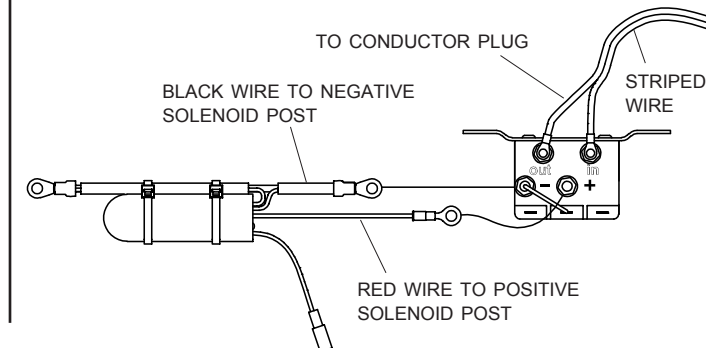

**STEP 5:** Connect SMART™ breaker to battery. Make jumper out of black 6-ga. wire (no stripe). Connect one end to battery negative post and bolt other ring terminal to SMART™ breaker. Insulate bolted connection with electrical tape.

**NOTE:** When splitting dual 6-ga. wire into separate halves to make jumper wires, use sharp knife to split webbing in order to prevent insulation from tearing and exposing metal strands.

**STEP 6:** Locate ShortStop™ circuit breaker within 1' of battery positive post. Make jumper wires out of 6-ga. wire (with stripe) for connecting ShortStop™ breaker between positive battery post and positive solenoid post. Connect breaker to positive solenoid post, but do not connect breaker to positive battery post at this time.

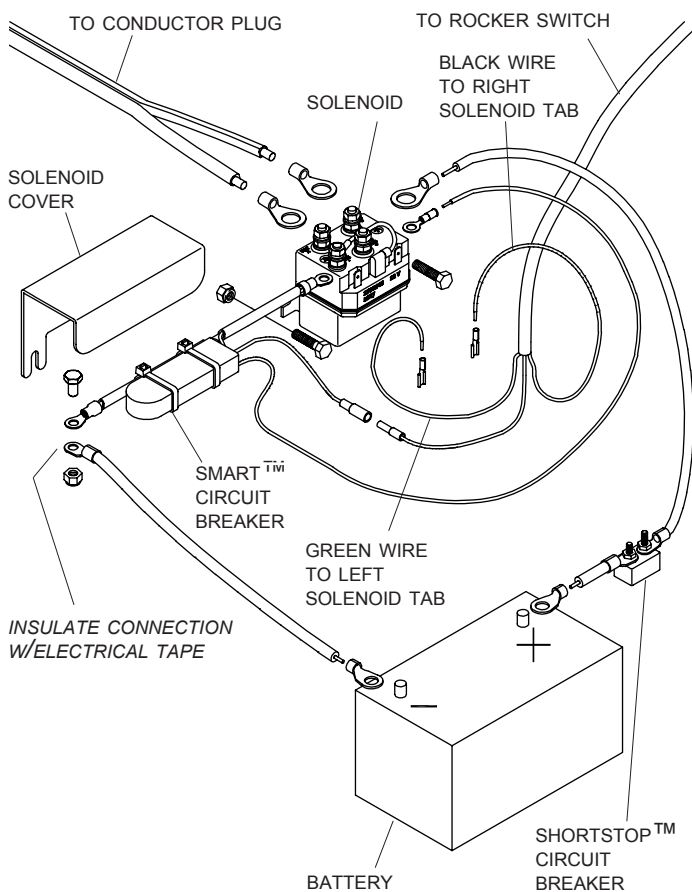

**STEP 7:** Mount rocker switch in cab in convenient location on dash panel or door jamb. Crimp female quick disconnects and connect to rocker switch as shown.

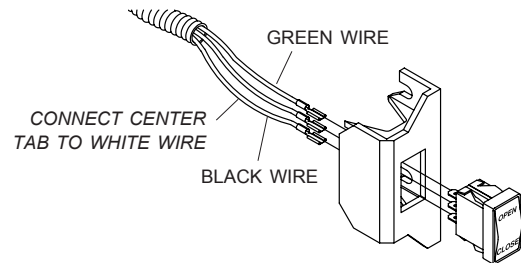

**STEP 8:** Route 14-ga. 3-conductor cable between rocker switch and solenoid.

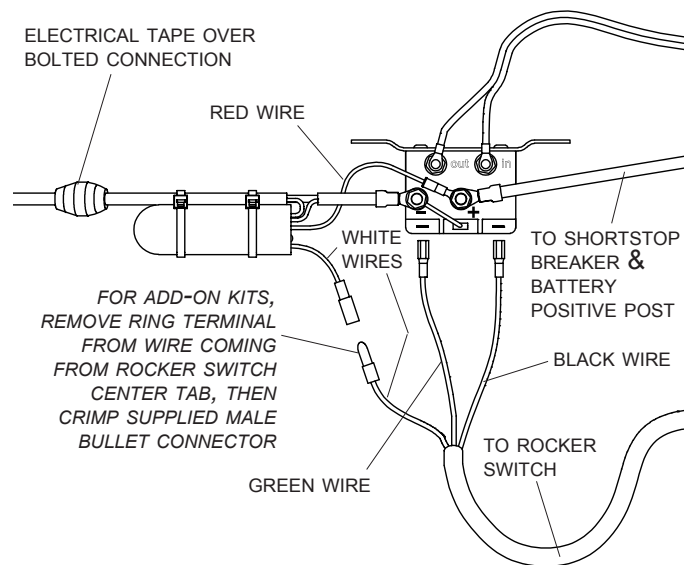

**STEP 9:** Mount solenoid cover over solenoid and tighten fasteners.

**STEP 10:** Connect ShortStop™ breaker to battery positive post and test operation.

**OPERATION**

**A) Check motor direction by activating switch to OPEN.** If switch is running system backwards, swap green and black quick disconnects on solenoid.

**B) Close tarp:** Push switch to CLOSE and hold. Observe tarp and release switch when tarp is fully closed.

**C) Open tarp:** Push switch to OPEN and hold. Observe tarp and release switch when tarp is fully open, but before it tightens against tarp stops.

**NOTE:** Release switch at end of cycle or SMART™ circuit breaker will trip. SMART™ breaker will reset after rocker switch is released. SMART™ breaker should always trip before ShortStop™ breaker™.

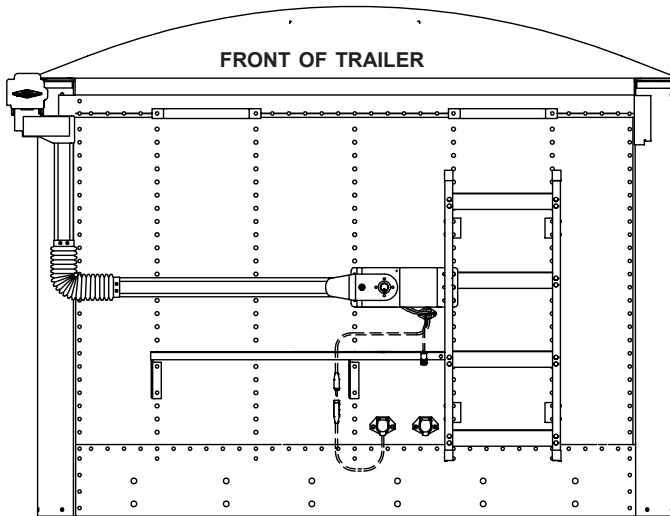

**NOTE:** Wire lengths are predetermined. Before installing SMARTwire™ components, review and confirm wire routing so wires reach components with ample room for connection.

**DUAL CONDUCTOR**

**STEP 1:** Locate dual-pole conductor socket near 7-pole conductor socket as shown. Determine location and drill 2" hole through trailer skin.

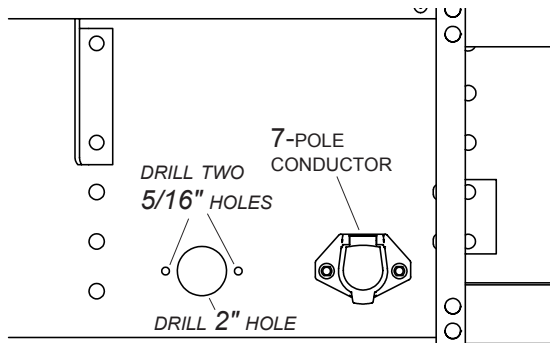

**STEP 2:** Align socket over 2" hole. Using holes in flanges on socket as guide, mark and drill two 5/16" holes.

**STEP 3:** Fasten conductor socket to trailer with screws (1), flat washers (2) and nuts (3).

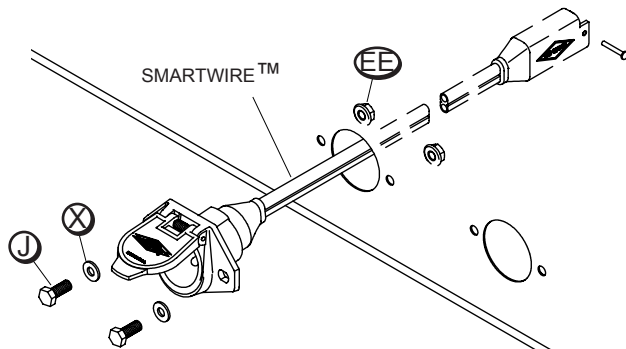

**CAUTION**

Do not cut SMARTwire™. Bind excess wire with cable ties.

**WIRING SCHEMATIC**

**STEP 1:** Connect SMARTwire™ from electric motor to SMARTwire™ from dual-conductor socket and secure connection with lock pin. Secure all wires to trailer with cable clips and screws. If needed, use cable ties.

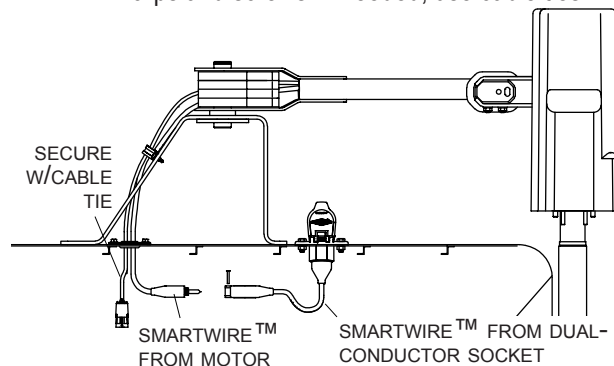

**NOTE:** Coat each connection with dielectric grease (P/N 1704378) to prevent corrosion.

**CAUTION**

Check all hardware for complete assembly before operating. Inspect system at this time and adjust as required.

**STEP 2:** Check motor direction by activating switch to OPEN. If switch is running system backwards, swap wire leads on two outside tabs on rocker switch.

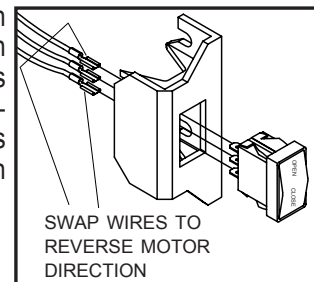

**OPERATION:**

**A) Close tarp:** Push switch to CLOSE and hold. Observe tarp and release switch when tarp is fully closed.

**B) Open tarp:** Push switch to OPEN and hold. Observe tarp and release switch when tarp is fully open.

**NOTE:** Release switch at end of cycle or modified-reset circuit breaker will trip. After breaker resets, switch will activate motor again. To reduce unnecessary strain on tarp components, release switch at end of each cycle.

Item	Part #	Description
1.	1115385	Heavy-Duty Dual-Conductor Plug
2.	1120670	SMARTwire™ Dual-Conductor Socket
3.	1704751	Harness Lock Pin - 1/4" x 7/8"
4.	1702108	Wire Clip - 3/4"
5.	1704354	40-Amp Modified-Reset Circuit Breaker
6.	1125008	SMART2™ Receiver - Rear Output
	1126860	SMART3™ Receiver - Rear Output
G.	1704338	Self-Tapping Screw - 1/4" x 1"
J.	1701045	Cap Screw - 5/16" x 3/4"
K.	1702926	Cap Screw - 5/16" x 7/8"
W.	1704946	Flanged Top Lock Nut - 5/16"
Y.	1700419	Lock Nut - 5/16"
EE.	1700427	Flat Washer - 1/4"
GG.	1700428	Flat Washer - 5/16"

**NOTE:** Only one electric tarp system can be hooked up at a time.

**NOTE:** Cut wires to length and strip only enough wire insulation to install ring terminals. Insert bare wire into ring terminals and crimp securely.

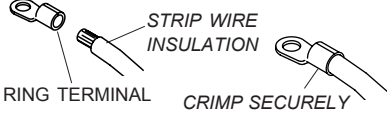

## NOTICE

**Do not power any Shur-Co® wireless system with battery charger alone, as this will likely cause system abnormalities and/or system malfunction. Instead, use a 12-volt truck/automobile battery to provide power to trailer.**

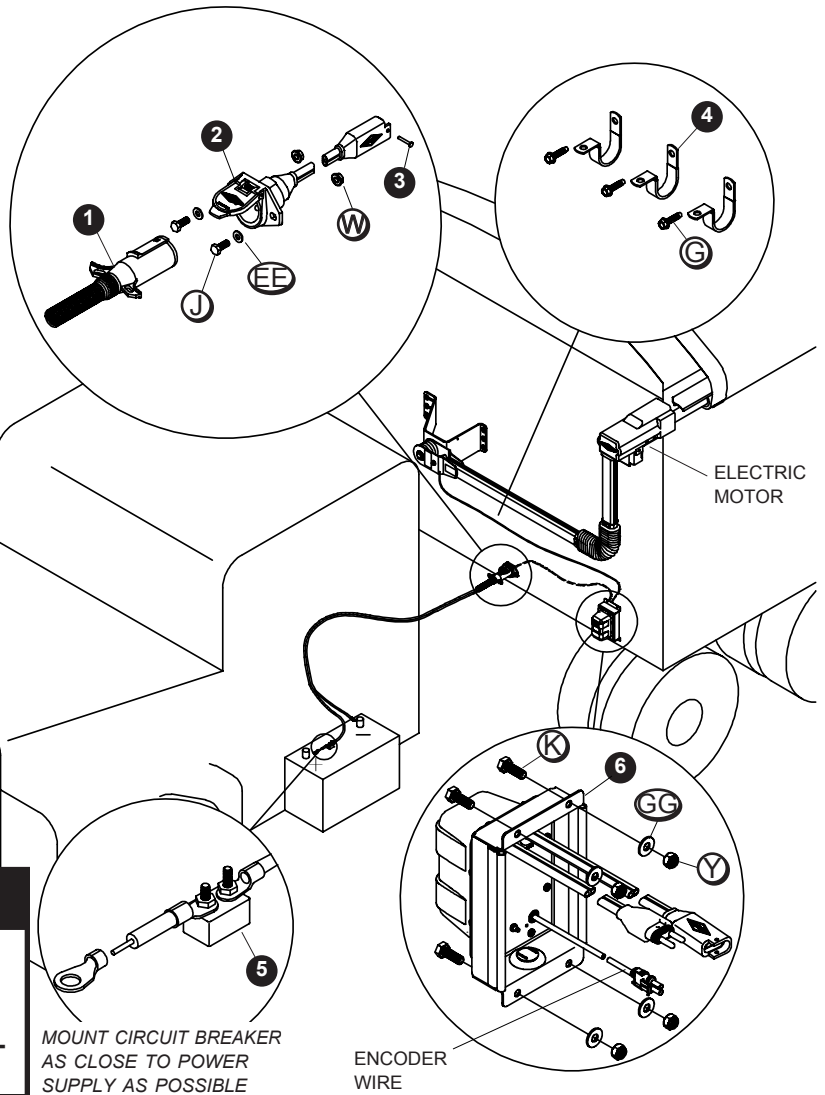

**STEP 1:** Mount circuit breaker as close as possible to battery or power supply.

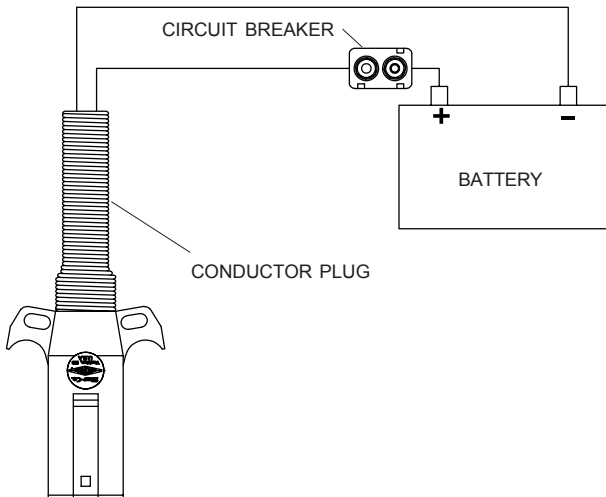

**STEP 2:** Unfasten and remove insert from conductor plug. Feed 6-ga. wire through plug and into brass contacts on insert. Tighten set screws to secure wires. Replace insert into conductor plug and secure screw.

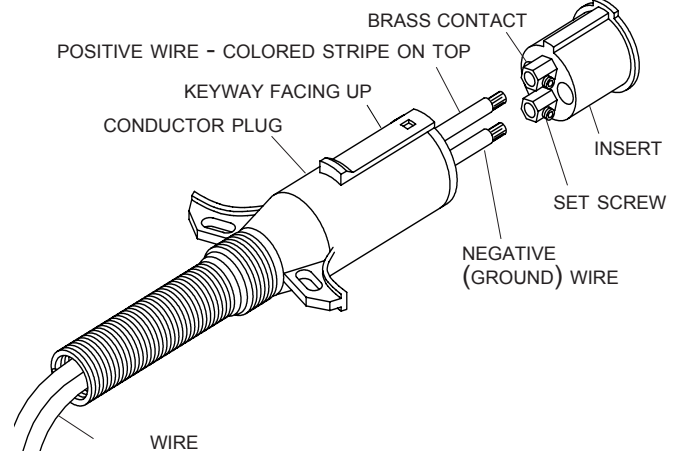



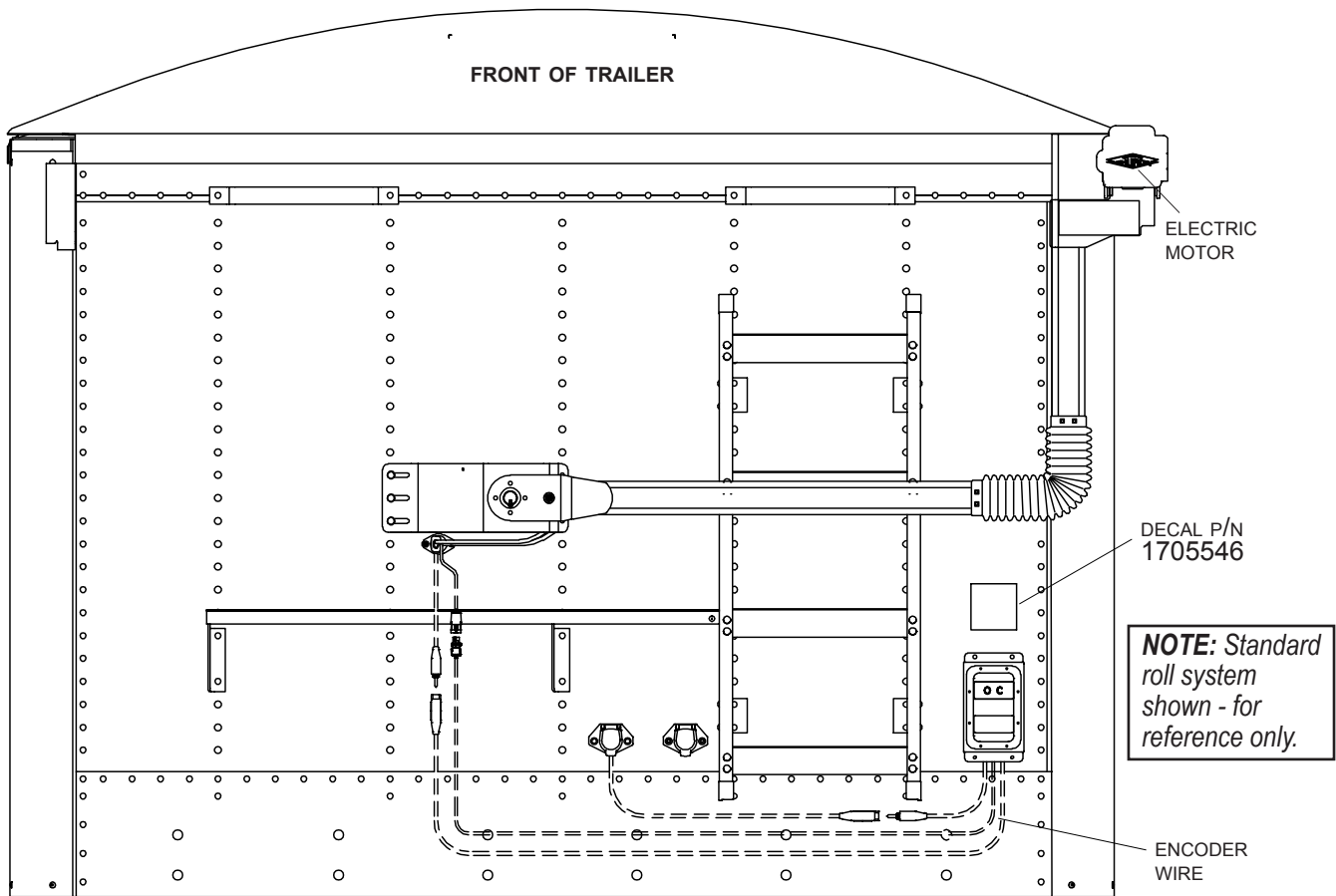

**NOTE:** Wire lengths are predetermined. Before installing SMARTwire™ components, review and confirm wire routing so wires reach components with ample room for connection.

**DUAL-CONDUCTOR SOCKET**

**STEP 1:** Locate dual-pole conductor socket near 7-pole conductor socket as shown. Determine location and drill 2" hole through trailer skin.

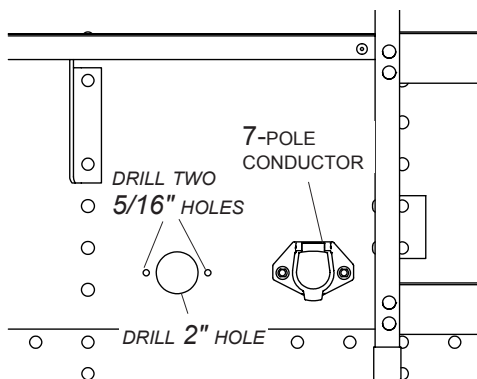

**STEP 2:** Align socket over 2" hole. Using holes in flanges on socket as guide, mark and drill two 5/16" holes.

**STEP 3:** Fasten conductor socket to trailer with screws , flat washers and nuts .

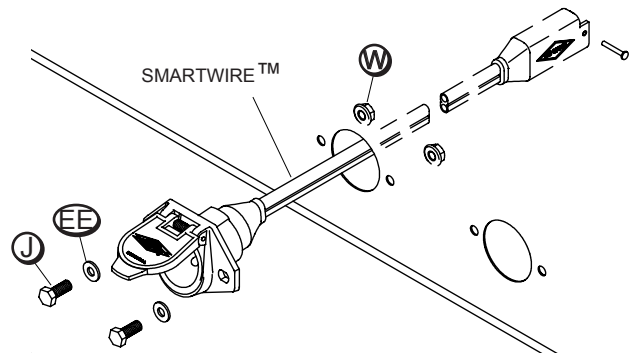

**CAUTION**  
Do not fasten SMARTwire™ components to trailer through hopper walls.



**SHUR-CO® WIRELESS RECEIVER**

**STEP 1:** In order to clear travel area of front arm, locate Shur-Co® wireless receiver as low as possible on front of trailer. Determine location and drill 2" hole through trailer skin.

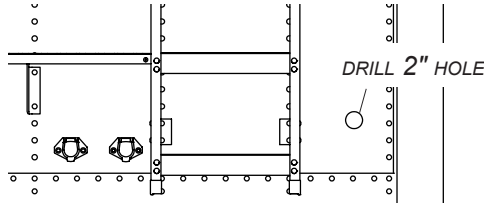

**STEP 2:** Align holes in wireless receiver over 2" hole in trailer as shown below. Using holes on flanges on receiver as guide, mark and drill four 5/16" holes as shown.

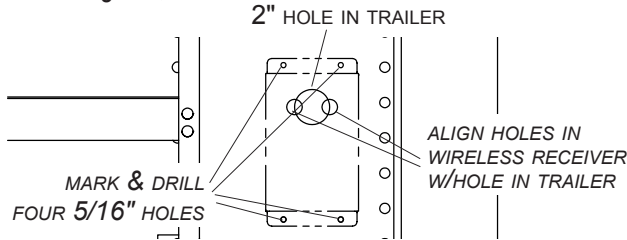

**STEP 3:** Install grommet into 2" hole. Insert wire from wireless receiver through grommet.

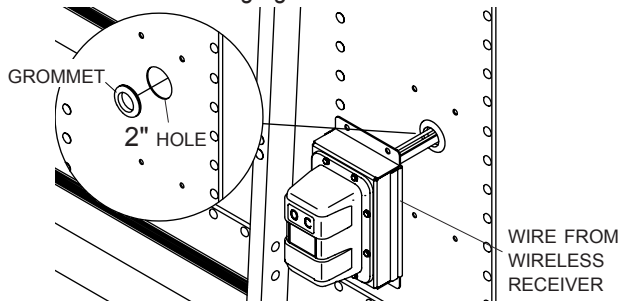

**STEP 4:** Align holes on wireless receiver with holes on trailer. Fasten receiver to trailer with screws (K), lock washers (GG) and nuts (Y). Adhere warning decal P/N 1705546 above receiver in location shown.

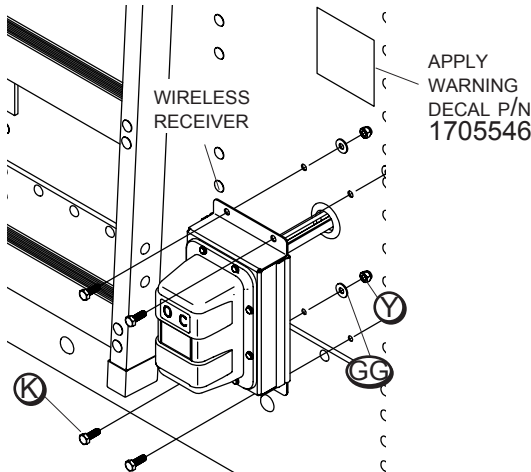

**WIRING SCHEMATIC**

**STEP 1:** Connect SMARTwire™ from wireless receiver to SMARTwire™ from electric motor. Connect SMARTwire™ plug from wireless receiver to SMARTwire™ from dual-conductor socket. Secure connections with lock pins. Connect encoder wire from receiver to encoder wire from motor. Secure wires to trailer with cable clips and screws. If needed, use cable ties.

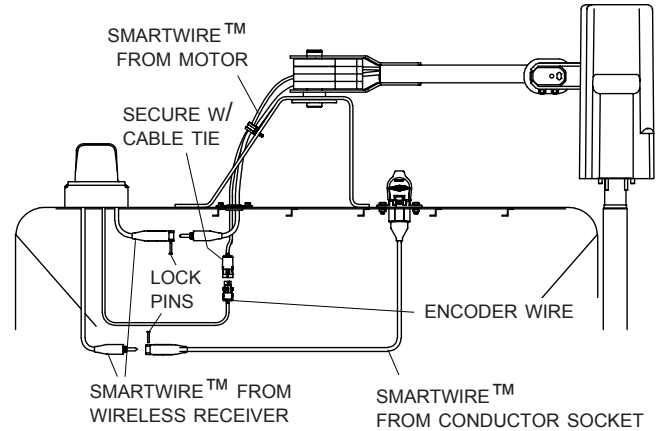

**CAUTION**  
Check all hardware for complete assembly before operating. Inspect system at this time and adjust as required.

**NOTE:** Coat each connection with dielectric grease (P/N 1704378) to prevent corrosion.

**STEP 2:** Check motor direction by pressing either button. If button is released and operation continues, system is in *Express Mode*. To stop operation, press button again. If switch is running system backwards, program remote to wireless receiver and rewire as directed in troubleshooting guide in remote instructions.

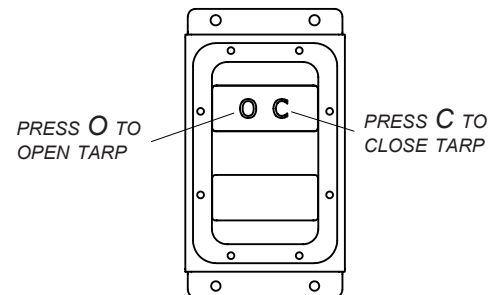

**NOTE:** Receiver may be pressure washed, but keep nozzle at least 3' from system while spraying.

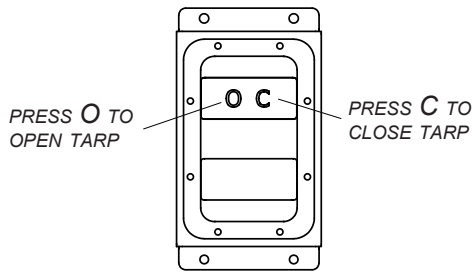

**NOTE:** 4500 Series HD trailer-mounted control boxes now operate in **EXPRESS MODE**. Pressing **O** or **C** button on control box initiates express open or close operation. After that, pressing either button will stop tarp operation. If neither button is pressed, operation will automatically stop at end of travel. On SMART2™ systems, if travel stops are not set, trailer-mounted control box operates in **MANUAL (momentary) MODE**. Remotes for both systems are shipped with tarp channel set to **EXPRESS MODE** and can be configured as desired.

**NOTE:** Tarp systems will operate in **EXPRESS MODE** when using buttons on trailer-mounted control box, if encoder wires are connected. For SMART2™ systems, travel stops must also be set, otherwise you must press and hold buttons. When in **EXPRESS MODE**, press and release buttons to open and close tarp (operation will continue until complete after releasing button). When in **MANUAL MODE**, press and hold buttons (operation will stop if button is released). See remote instruction manual for detailed instructions on remote operation.

**NOTE:** Tarp systems operate in **EXPRESS MODE** when commanded to operate from buttons on trailer-mounted control box. Closing remote lid or pressing select button will not stop system in this case. Pressing **OPEN** or **CLOSE** button on remote will stop system if in range.

**NOTE:** Tarp systems operate in **EXPRESS MODE** when using buttons on trailer-mounted control box, if encoder wires are connected. For SMART2™ systems, travel stops must also be set. Otherwise you must press and hold buttons (see remote instructions for SMART2™ systems).

**WARNING**

**DO NOT OPERATE  
MOTORIZED SYSTEMS  
WHILE INDIVIDUALS  
ARE ON OR OCCUPYING  
BOX/TRAILER/HOPPER.**

Decal P/N 1705546

**NOTICE**

THIS TARP SYSTEM OPERATES IN EXPRESS MODE. UPON PRESSING THE **O**PEN/**C**LOSE BUTTON THE TARP SYSTEM WILL CONTINUE TO TRAVEL TO THE END STOPS. TO STOP THE MOTOR, PRESS EITHER BUTTON. READ OWNERS MANUAL BEFORE OPERATING. CONTACT SHUR-CO® FOR ALL TARP SYSTEM QUESTIONS AT 1-866-748-7435.

**NOTICE**

Decal shown above must be placed above wireless receiver on front of box.

**WARNING**

Stay clear of roll tarp and arm(s) area of travel during operation. Failure to do so could result in serious injury or death.

**WARNING**

Stay clear of the roll tarp and arm(s) sweep area, from front-to-back, during operation. Failure to do so may result in a fall/impact causing serious injury or death. For repair/service of equipment, reference manual for proper safety precautions before proceeding.

Decal P/N 1705523

**WARNING**

Stay clear of the roll tarp and arm(s) sweep area, from front-to-back, during operation. Failure to do so may result in a fall/impact causing serious injury or death. For repair/service of equipment, reference manual for proper safety precautions before proceeding.

4500HD

1-800-474-8756  
SHURCO.com

NO STEP

Perform following steps to change 4500 HD Series Electric system to manual crank operation:

**NOTE:** Store manual crank arm in truck or mounted to trailer.  
(Example - above kingpin in the apex.)

**STEP 1:** Close tarp, letting roll tube hang loose under latchplate.

**STEP 2:** At front of trailer, remove screw **Q** and lock nut **BB** from motor shaft and roll tube extension connection.

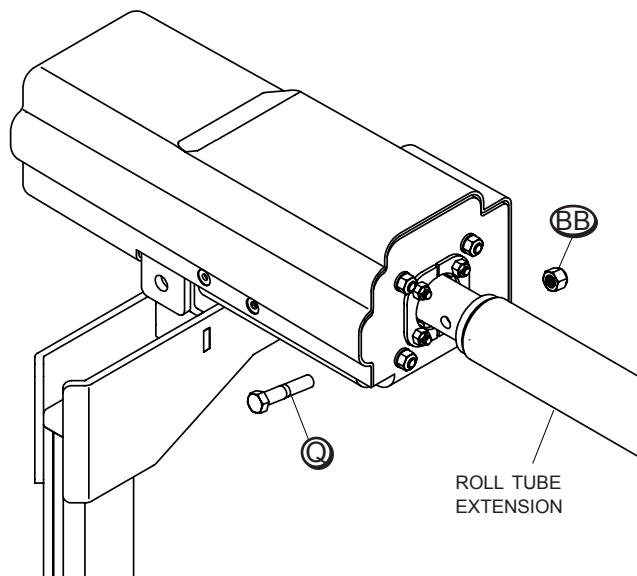

**STEP 3:** Remove protective cap and install crank arm assembly as shown in Shur-Lok® owner's manual. View owner's manual at <http://www.shurco.com>.

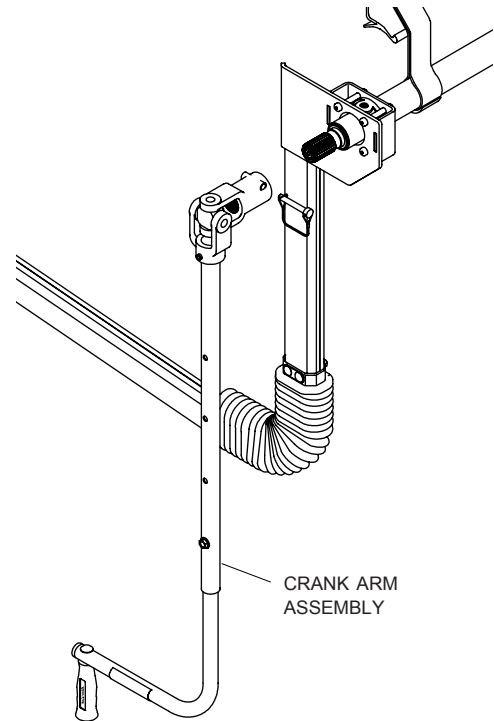

## CAUTION

Do not open or close tarp without U-joint securely fastened to splined shaft with wire lock pin. Failure to do so could result in injury.

## REMOVE EXISTING MOTOR

**STEP 1:** Close tarp, letting roll tube hang loose under latchplate.

**STEP 2:** Disconnect electric power to trailer. Unfasten and remove motor cover. Unfasten screw **Ⓐ** and lock nut **Ⓑ** holding motor shaft to roll tube extension.

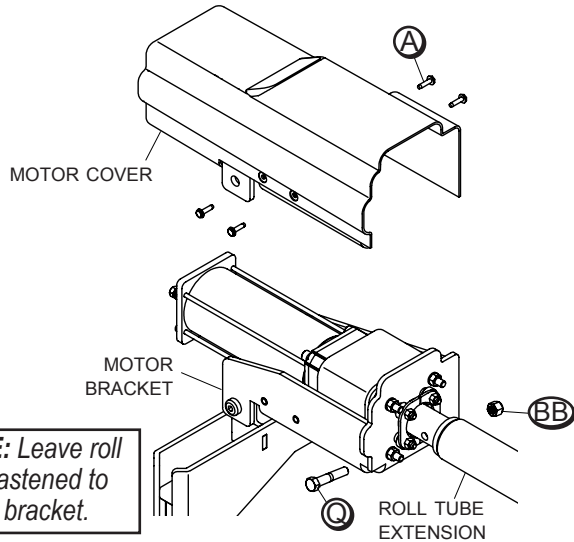

**NOTE:** Leave roll tube fastened to motor bracket.

**STEP 3:** Disconnect electric wires from motor terminals and encoder wire.

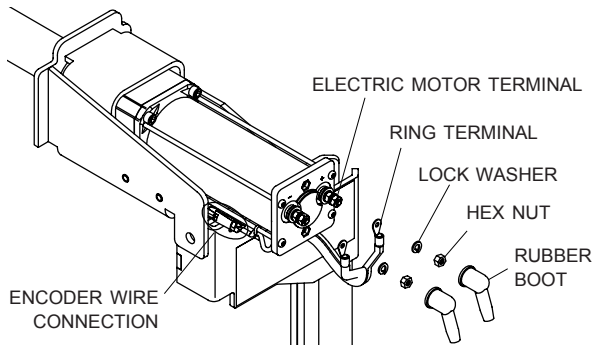

**STEP 4:** Unfasten and remove only 5/16" lock washers and hex nuts holding motor to motor bracket/front arm assembly, leaving motor mount bearing retainers in place. Remove existing motor.

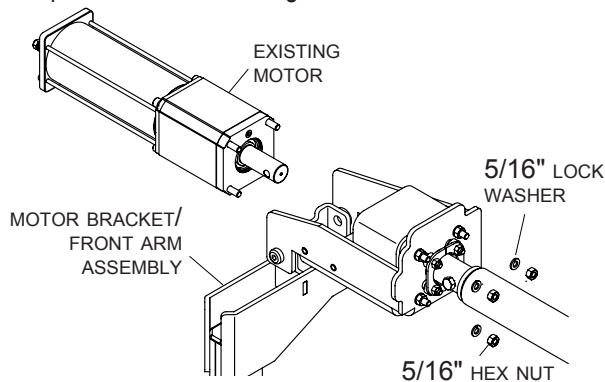

## INSTALL NEW MOTOR

**STEP 1:** Install new motor. Fasten motor to motor bracket with 5/16" washers and nuts.

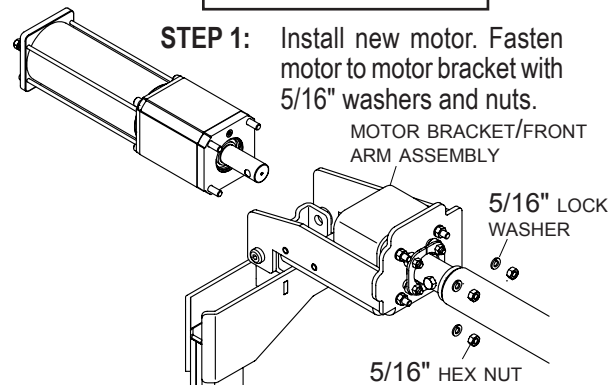

**STEP 2:** Connect electric wires to motor terminals and encoder wire.

**NOTE:** Connect black wire with red stripe to negative post and solid black wire to positive post.

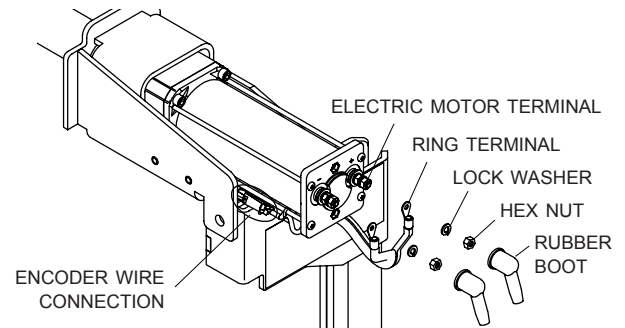

**STEP 3:** Fasten motor shaft to roll tube extension with screw **Ⓐ** and lock nut **Ⓑ**. Replace motor cover and fasten to motor with screws **Ⓐ**. Reconnect electric power.

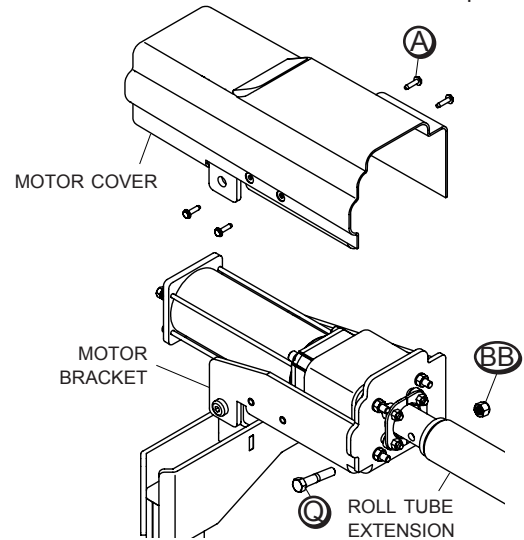

## CAUTION

Check all hardware for complete assembly before operating. Inspect system at this time and adjust as required.

**NOTE:** Replace system parts only with Genuine Shur-Co® parts to ensure proper system function. If Genuine Shur-Co® parts are not used, warranty could be void.

**NOTE:** 2" roll tube components are shown on this page. 3" roll tube components are shown on page 31.

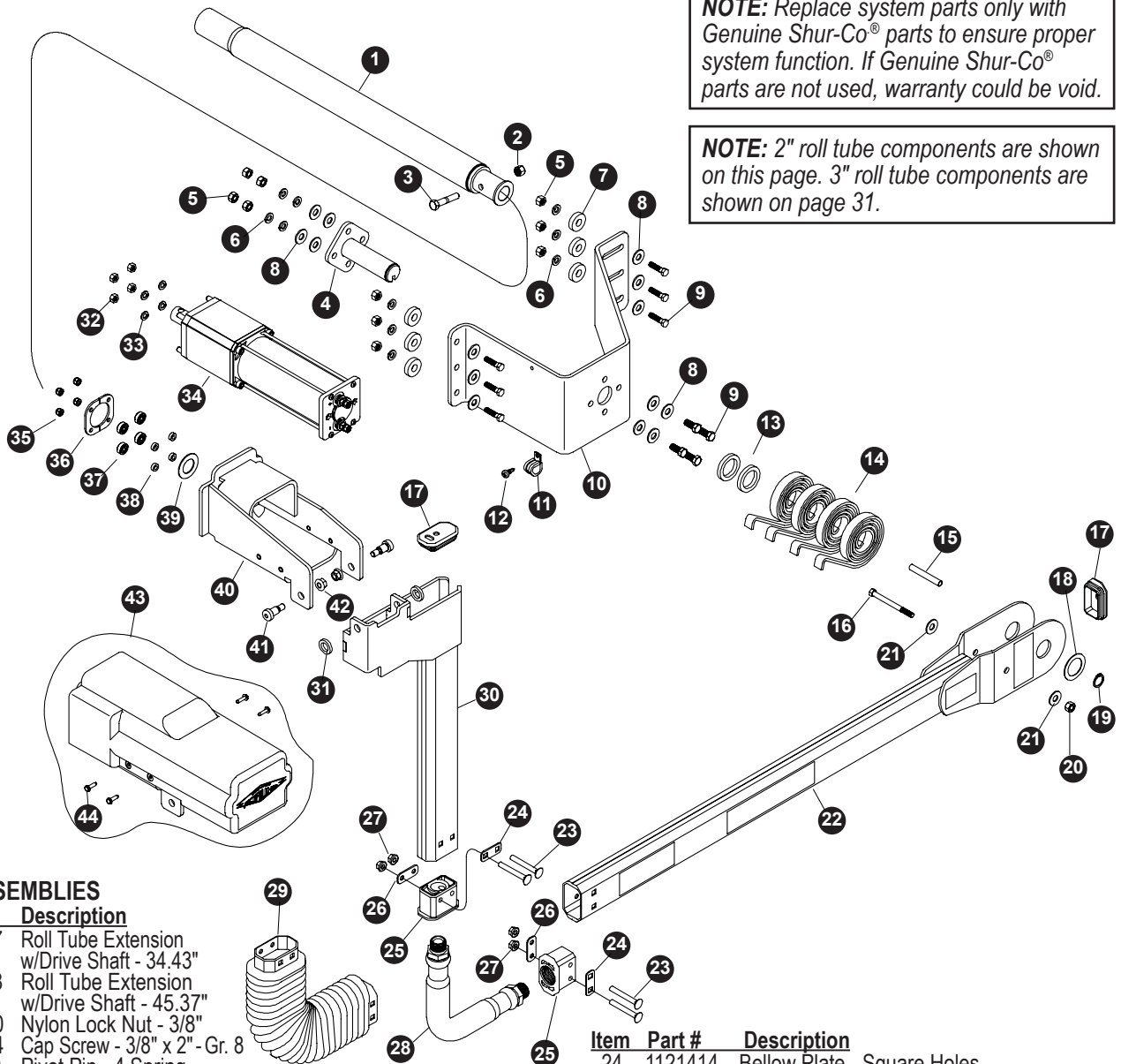

**FRONT ASSEMBLIES**

Item	Part #	Description
1.	1120697	Roll Tube Extension w/Drive Shaft - 34.43"
	1120698	Roll Tube Extension w/Drive Shaft - 45.37"
2.	1701580	Nylon Lock Nut - 3/8"
3.	1704264	Cap Screw - 3/8" x 2" -Gr. 8
4.	1116920	Pivot Pin - 4 Spring
5.	1700407	Hex Nut - 3/8"
6.	1700434	Lock Washer - 3/8"
7.	1120291	Pivot Bracket Washer
8.	1700429	Flat Washer - 3/8"
9.	1702891	Cap Screw - 3/8" x 1 1/4"
10.	1121578	Pivot Mt. Bracket - Vertical - 9-1/4" Standoff
	1121582	Pivot Mt. Bracket - Vertical - 7-1/4" Standoff
11.	1702108	Wire Clip - 3/4" ID
12.	1700398	Self-Drilling Screw - 3/8" x 3/4"
13.	1118318	Spacer Washer - 1/4" x 1.81" OD x 1.28"
14.	1111027	Spiral Torsion Spring
15.	1117033	Spacer Tube - .35" x 2-5/8"
16.	1201022	Cap Screw - 5/16" x 3-1/2"
17.	1704893	Cap Plug w/Hole
18.	1702890	Flat Washer - 1 1/4"
19.	1702888	External Retaining Ring - 1-1/4"
20.	1700419	Nylon Lock Nut - 5/16"
21.	1700428	Flat Washer - 5/16"
22.	1121294	Lower Flex Arm w/Warning Decals (Includes items 15; 16; 20; 21; 22)
23.	1701455	Carriage Bolt - 5/16" x 2-1/2"

Item	Part #	Description
24.	1121414	Bellow Plate - Square Holes
25.	1704891	End Fitting - 4500 Series HD
26.	1121413	Bellow Plate - Round Holes
27.	1704931	Flanged Nylon Lock Nut - 5/16"
28.	1703873	Flex Arm Joint
29.	1704775	4500 Series HD Bellow
30.	1121619	Upper Flex Arm - Motor - RR
31.	1120677	Upper Arm Spacer
32.	1700411	Hex Nut - 5/16"
33.	1700433	Lock Washer - 5/16"
34.	1120967	4500 Series HD Electric Motor
35.	1701543	Nylon Lock Nut - 1/4"
36.	1128243	Motor Mount Bearing Retainer
37.	1704736	Radial Ball Bearing - 1/4" x 3/4"
38.	1120680	Motor Mount Bearing Spacer
39.	1120679	Motor Spacer
40.	1120776	4500 Series HD Motor Mount - 7-1/4"
	1120662	4500 Series HD Motor Mount
41.	1704778	Shoulder Bolt - 1/2" x 5/8" - 3/8" x 1/2" Thd.
42.	1701283	Flanged Top Lock Nut - 3/8"
43.	1121659	4500 Series HD Motor Cover Kit - Black
44.	1704367	Hex Flange Cap Screw - #10 x 3/4"



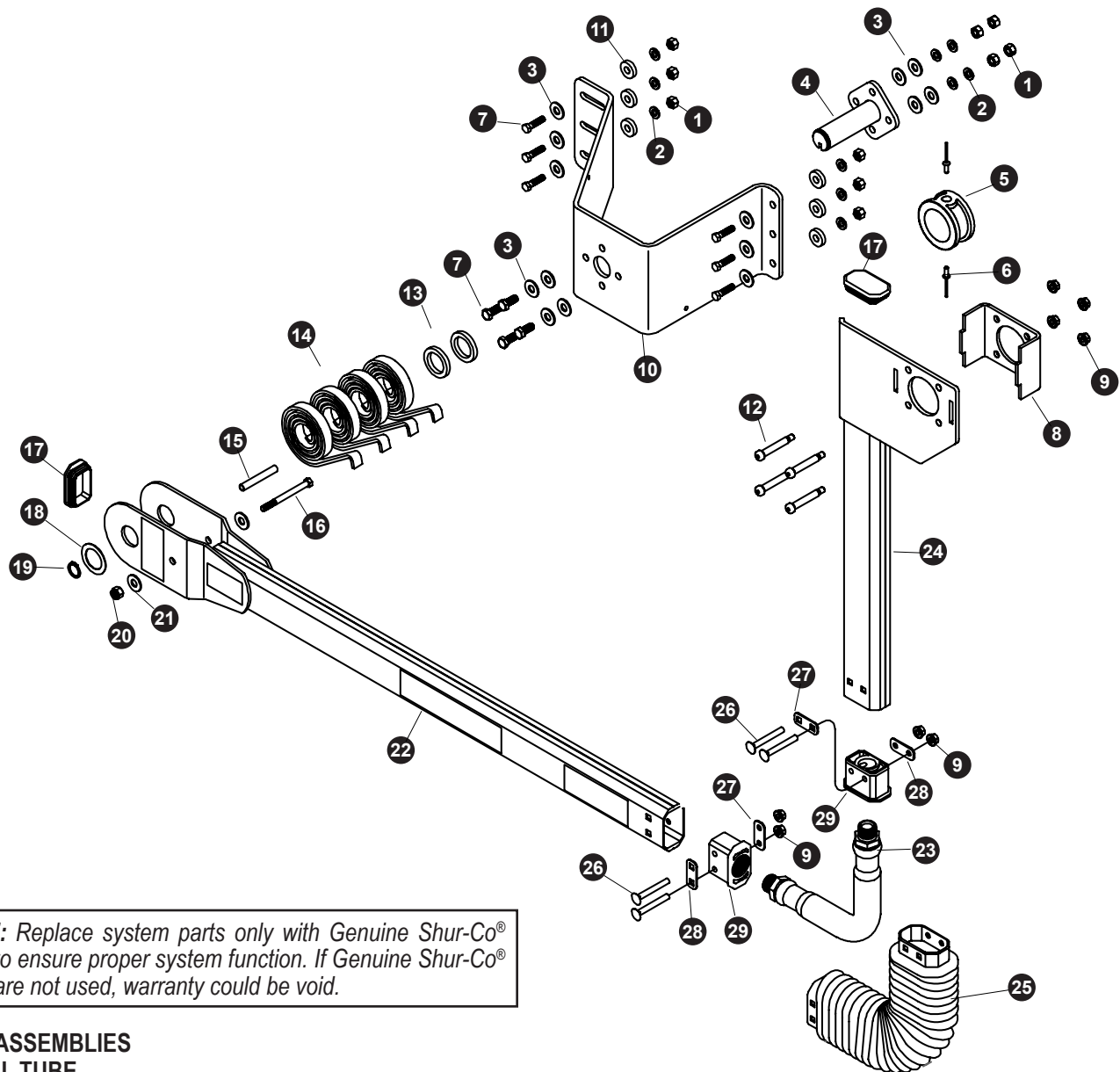

**NOTE:** Replace system parts only with Genuine Shur-Co® parts to ensure proper system function. If Genuine Shur-Co® parts are not used, warranty could be void.

**REAR ASSEMBLIES**

**2" ROLL TUBE**

**Item Part # Description**

- 1. 1700407 Hex Nut - 3/8"
- 2. 1700434 Lock Washer - 3/8"
- 3. 1700429 Flat Washer - 3/8"
- 4. 1116920 Pivot Pin - 4 Spring
- 5. 1704942 Rear Arm Bearing Ring - 2"
- 6. 1706103 Blind Rivet - 3/16"
- 7. 1702891 Cap Screw - 3/8" x 1-1/4"
- 8. 1121430 Bearing Mount Box - 2"
- 9. 1704931 Flanged Nylon Lock Nut - 5/16"
- 10. 1121578 Pivot Mt. Bracket - Vertical - 9-1/4" Standoff
- 11. 1121582 Pivot Mt. Bracket - Vertical - 7-1/4" Standoff
- 12. 1704943 Shoulder Bolt - 3/8" x 2" - 5/16" x 1/2" Thd.
- 13. 1118318 Spacer Washer - 1/4" x 1.81" OD x 1.28"
- 14. 1111027 Spiral Torsion Spring
- 15. 1117033 Spacer Tube - .35" x 2-5/8"

**Item Part # Description**

- 16. 1201022 Cap Screw - 5/16" x 3-1/2"
- 17. 1704892 Cap Plug
- 18. 1702890 Flat Washer - 1-1/4"
- 19. 1702888 External Retaining Ring - 1-1/4"
- 20. 1700419 Nylon Lock Nut - 5/16"
- 21. 1700428 Flat Washer - 5/16"
- 22. 1121617 Lower Flex Arm w/Warning Decals (Includes items 15; 16; 20; 21; 22)
- 23. 1703873 Flex Arm Joint
- 24. 1121281 Upper Flex Arm - Bearing - 2" - RR
- 25. 1704775 4500 Series HD Bellow
- 26. 1701455 Carriage Bolt - 5/16" x 2-1/2"
- 27. 1121413 Bellow Plate - Round Holes
- 28. 1121414 Bellow Plate - Square Holes
- 29. 1704891 End Fitting



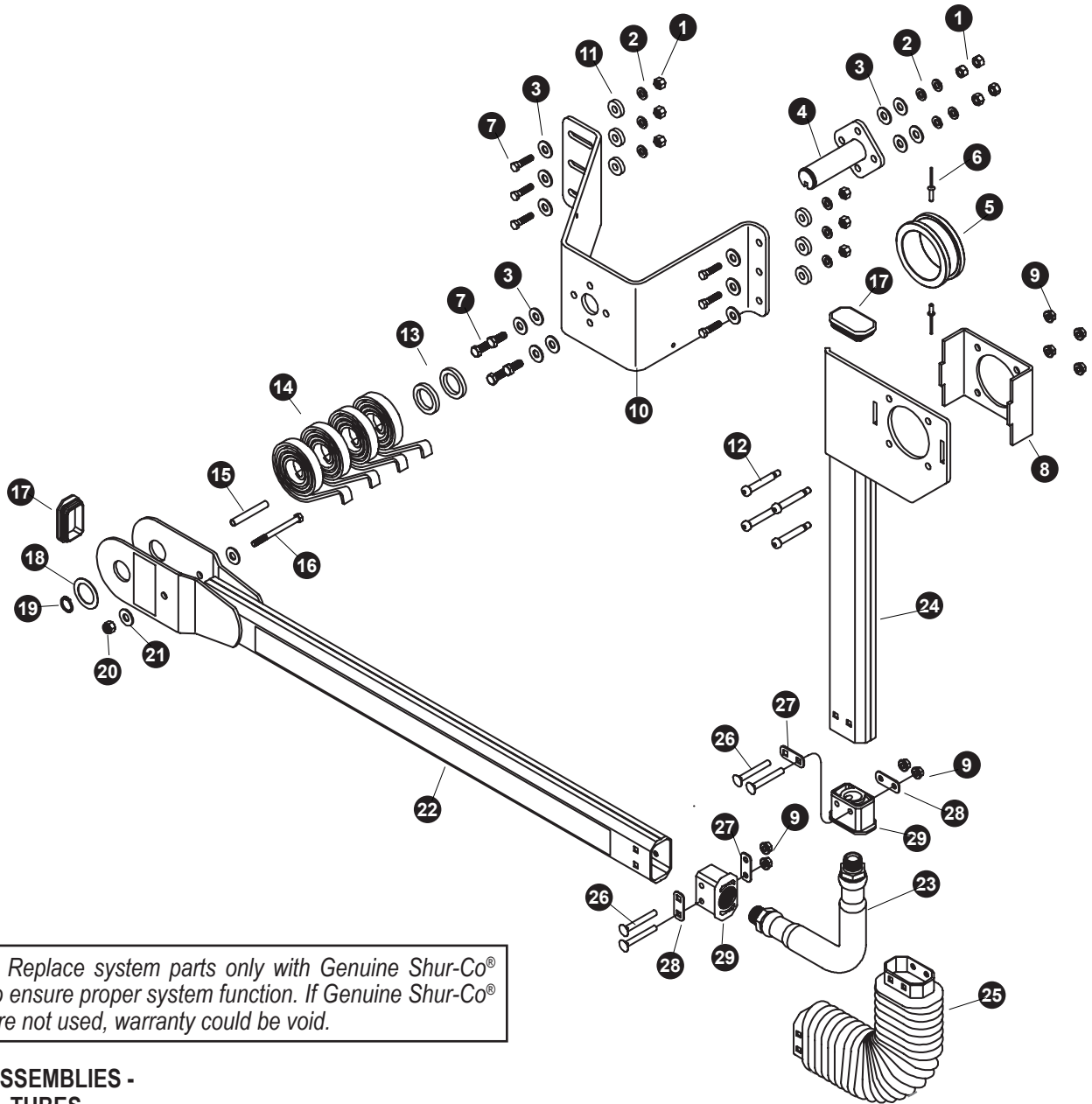

**NOTE:** Replace system parts only with Genuine Shur-Co® parts to ensure proper system function. If Genuine Shur-Co® parts are not used, warranty could be void.

**REAR ASSEMBLIES -  
3" ROLL TUBES**

**Item Part # Description**

- 1. 1700407 Hex Nut - 3/8"
- 2. 1700434 Lock Washer - 3/8"
- 3. 1700429 Flat Washer - 3/8"
- 4. 1116920 Pivot Pin - 4 Spring
- 5. 1705160 Rear Arm Bearing Ring - 3"
- 6. 1706103 Blind Rivet - 3/16"
- 7. 1702891 Cap Screw - 3/8" x 1-1/4"
- 8. 1123248 Bearing Mount Box - 3"
- 9. 1704931 Flanged Nylon Lock Nut - 5/16"
- 10. 1121578 Pivot Mt. Bracket - Vertical - 9-1/4" Standoff
- 11. 1121582 Pivot Mt. Bracket - Vertical - 7-1/4" Standoff
- 12. 1120291 Pivot Bracket Washer
- 13. 1704943 Shoulder Bolt - 3/8" x 2" - 5/16" x 1/2" Thd.
- 14. 1118318 Spacer Washer - 1/4" x 1.81" OD x 1.28"
- 15. 1111027 Spiral Torsion Spring
- 16. 1117033 Spacer Tube - .35" x 2-5/8"

**Item Part # Description**

- 16. 1201022 Cap Screw - 5/16" x 3-1/2"
- 17. 1704892 Cap Plug
- 18. 1702890 Flat Washer - 1-1/4"
- 19. 1702888 External Retaining Ring - 1-1/4"
- 20. 1700419 Nylon Lock Nut - 5/16"
- 21. 1700428 Flat Washer - 5/16"
- 22. 1121294 Lower Flex Arm w/Warning Decals (includes items 15; 16; 20; 21; 22)
- 23. 1703873 Flex Arm Joint
- 24. 1124958 Upper Flex Arm - Bearing - 3" - RR
- 25. 1704775 4500 Series HD Bellow
- 26. 1701455 Carriage Bolt - 5/16" x 2-1/2"
- 27. 1121413 Bellow Plate - Round Holes
- 28. 1121414 Bellow Plate - Square Holes
- 29. 1704891 End Fitting

**4500 SERIES HD ELECTRIC COMPONENTS**

Item	Part #	Description
1.	1702108	Wire Clip - 3/4"
2.	1704338	Self-Tapping Screw - 1/4" x 1"
3.	1703231	Cable Tie - 8"
4.	1700407	Hex Nut - 3/8"
5.	1700434	Lock Washer - 3/8"
6.	1109015	Mounting Bracket
7.	1700400	Self-Tapping Screw - 3/8" x 1"
8.	1700408	Hex Nut - 1/4"
9.	1700436	Lock Washer - 1/4"
10.	1700427	Flat Washer - 1/4"
11.	1700403	Self-Tapping Screw - 1/4" x 3/4"
12.	1704987	SMARTwire™ - 6 Ga. - Plug x 1/4" Terminal x 10'9
13.	1120670	SMARTwire™ Dual-Conductor Socket
14.	1704946	Flanged Top Lock Nut - 5/16"
15.	1701045	Cap Screw - 5/16" x 3/4"
16.	1115385	Heavy-Duty Dual-Conductor Plug
17.	1704751	Harness Lock Pin - 1/4" x 7/8"
18.	1704354	40-Amp Modified-Reset Circuit Breaker
19.	1705624	50-Amp SMART™ Circuit Breaker
20.	1116020	Rocker Switch
21.	1703661	Rocker Switch Mounting Bracket
22.	1703896	Solenoid Cover
23.	1808844	Nylon Lock Nut - #10
24.	1703845	Motor-Reversing Solenoid
25.	1704905	Hex Flanged Cap Screw - #10 x 1"
26.	1700419	Lock Nut - 5/16"
27.	1700427	Flat Washer - 1/4"
28.	1202938	Rubber Grommet - 1-1/2" Insert
29.	1126860	Shur-Co® Wireless Receiver - SMART3 w/SMARTwire™
	1125008	Shur-Co® Wireless Receiver - Version 11 - SMART2™ w/SMARTwire™ (only compatible with version 11 remote)
30.	1702926	Cap Screw - 5/16" x 7/8"
31.	1126867	5-Channel SMART3™ Remote
32.	1122231	SMART2™ Remote w/Cradle
33.	1704957	SMART2™ Cradle
34.	1704958	SMART2™ Charger Cable
35.	1704312	Motor-Reversing Solenoid - 3 Pt. Mt.
36.	1704308	Flanged Cap Screw - #10 x 1/2"

**NOTE:** To check remote version, go to **SETUP**, then select **INFORMATION**. Call Shur-Co's Help Line, if needed.

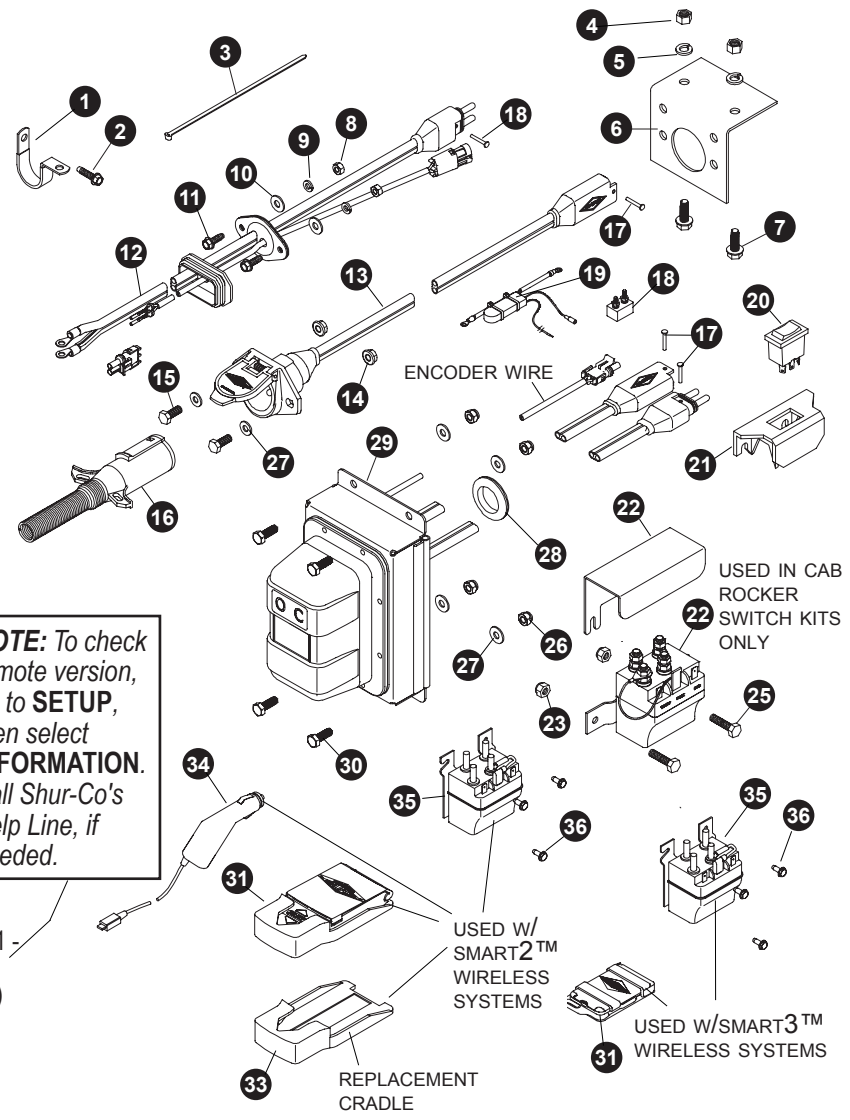

**HD SLOPED PIVOT MOUNTS**

Item	Part #	Description
1.	1700429	Flat Washer - 3/8"
2.	1700434	Lock Washer - 3/8"
3.	1700407	Hex Nut - 3/8"
4.	1116920	Pivot Pin - 4 Spring
5.	1702891	Cap Screw - 3/8" x 1-1/4"
6.	1120291	Pivot Bracket Washer
7.	1121993	Pivot Mount Bracket - Sloped - 6" Standoff - 6" Wide
	1121994	Pivot Mount Bracket - Sloped - 8" Standoff - 6" Wide
8.	1121992	Pivot Bracket - Sloped - 6" Wide
9.	1700400	Self-Tapping Screw - 3/8" x 1"
10.	1120361	Pivot Backer Plate - 7" x 16"
	1120418	Pivot Backer Plate - 7" x 20"

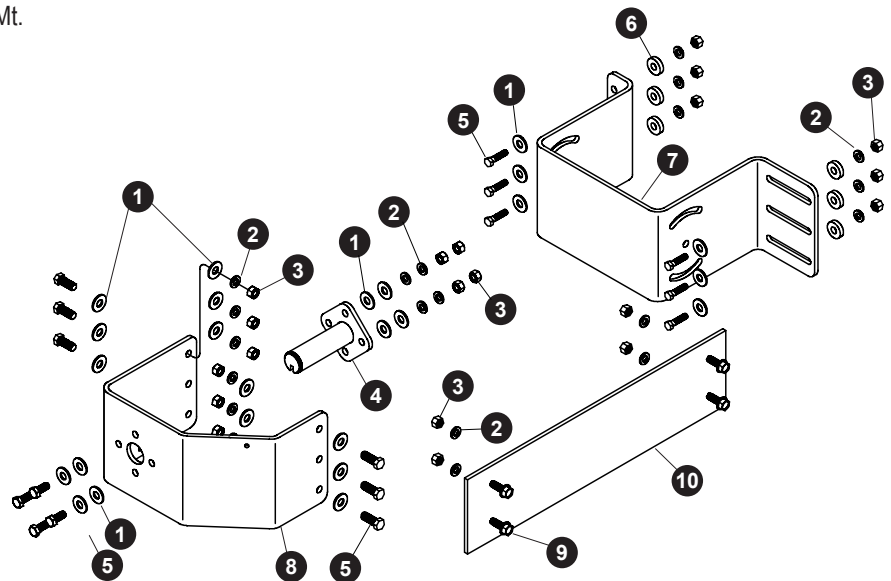

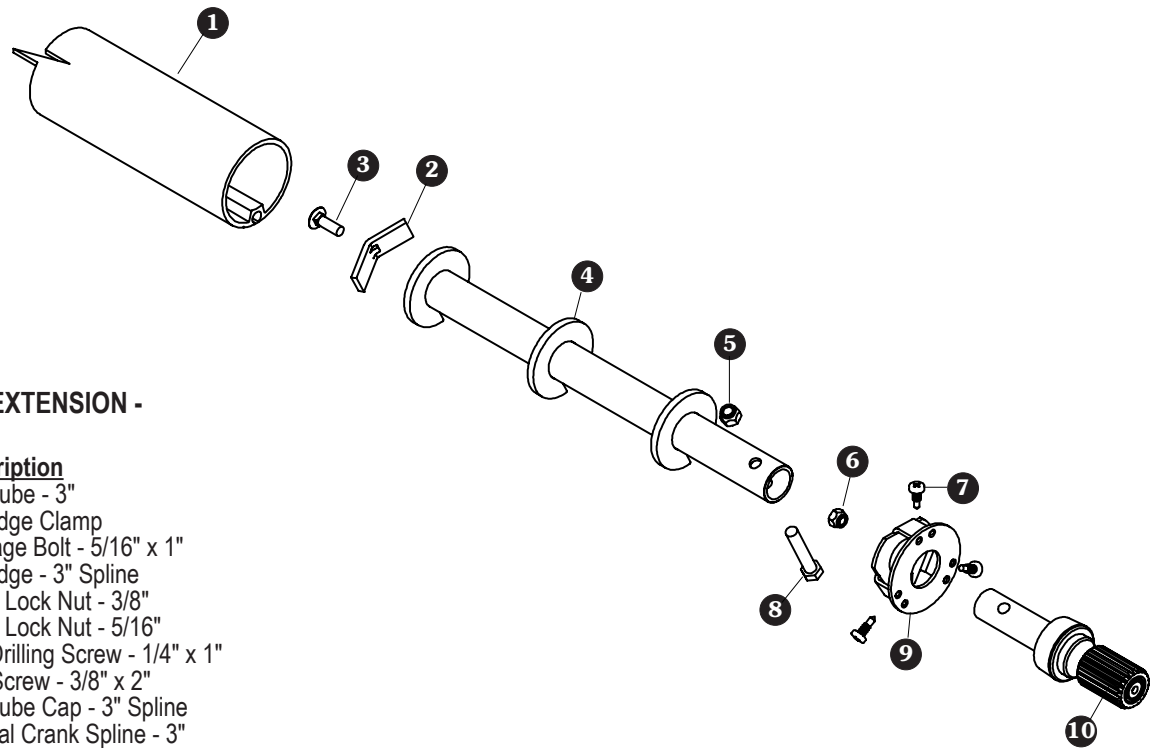

**REAR ROLL TUBE EXTENSION -  
3" ROLL TUBE**

Item	Part#	Description
1.	1704568	Roll Tube - 3"
2.	1118194	Cartridge Clamp
3.	1704237	Carriage Bolt - 5/16" x 1"
4.	1121039	Cartridge - 3" Spline
5.	1701580	Nylon Lock Nut - 3/8"
6.	1704297	Nylon Lock Nut - 5/16"
7.	1705198	Self-Drilling Screw - 1/4" x 1"
8.	1704264	Cap Screw - 3/8" x 2"
9.	1121040	Roll Tube Cap - 3" Spline
10.	1121111	Manual Crank Spline - 3"

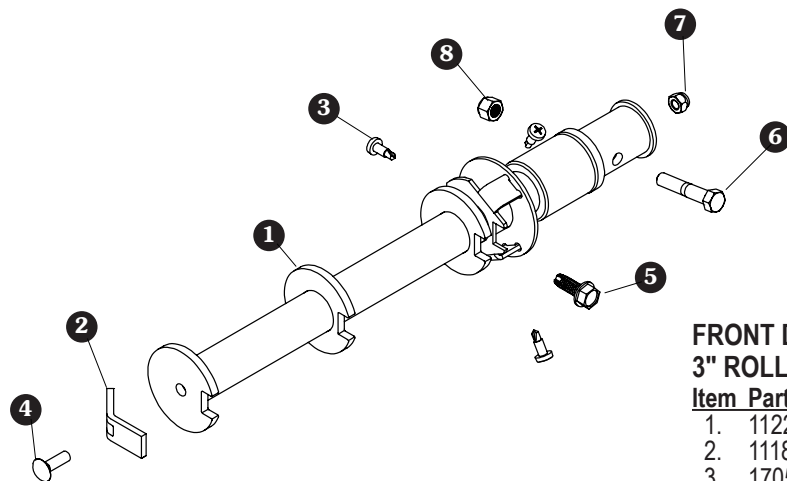

**FRONT DRIVE SHAFT -  
3" ROLL TUBE**

Item	Part #	Description
1.	1122264	Drive Shaft
2.	1118194	Cartridge Clamp
3.	1705198	Self-Drilling Screw - 1/4" x 1"
4.	1704237	Carriage Bolt - 5/16" x 1"
5.	1700400	Self-Tapping Screw - 3/8" x 1"
6.	1704264	Cap Screw - 3/8" x 2" - GR8
7.	1704297	Nylon Lock Nut - 5/16"
8.	1701580	Nylon Lock Nut - 3/8"

# MORE QUALITY PRODUCTS FROM SHUR-CO®

---

- Genuine Replacement Tarps
- Genuine Replacement Parts
  
- Agriculture Products
  - *The Original Shur-Lok*®
  - Turning Point™ Bow
  - Shur-Lok® Junior
  - Premium Belt 'n Ratchet
  - Cable-Lok™
  - Tater-Top™
  
- SMARTrailer™ Accessories for Agriculture Products
  - SMART2™ Remote
  - SMART3™ Remote
  - 4500 Series HD Electric
  - Electric Shur-Lok®
  - AutoTrap™ Hopper Opener
  - ProTrap® Hopper Opener
  - Electric Gate & Hoist
  - DriveMaxx™ Auger Drive
  - Electric Farm Swing Gate
  - LiteALL™ Work Lights
  - Cable-Lok™ Electric Upgrade
  - Electric Turning Point™ Bow
  - Solar Power Pack
  - Tater-Top™ Electric
  - Service Truck Power Kit
  
- Construction Products
  - *The Original Shur-Lok*®
  - Turning Point™ Bow
  - Shur-Trak II™
  - IronSide II™
  - Shur-Matic™
  
- SMARTrailer™ Accessories for Construction Products
  - 4500 Series HD Electric w/Gate Flex™
  - Shur-Trak II™ Electric Upgrade
  - Electric Turning Point™ Bow
  - Solar Power Pack
  
- Custom Products
  - Fitted Truck Covers
  - Flat Utility Tarps
  - Bean Drill Covers
  - Gustbuster™ Tarp Cords
  - SMARTwire™

TARPING SYSTEMS & ACCESSORIES

