



TARPING SYSTEMS & ACCESSORIES

P/N 1123574 Rev. C

OWNER'S MANUAL



SMARTwire™ Hopper Door Opener

READ BEFORE INSTALLING

PO BOX 713 ■ 2309 SHUR-LOK STREET ■ YANKTON, SD 57078-0713
PHONE 1-800-4-SHUR-LOK (1-800-474-8756) ■ FAX 605-665-0501
www.shurco.com

SHOP ONLINE: www.shopshurco.com

SHIPPING. Orders are shipped F.O.B. from the Shur-Co®, LLC sites listed below. No full freight is allowed or prepaid shipment accepted unless quoted and approved in writing prior to acceptance of the order. All shipments are made by the most reasonable means in accordance with size and weight of order, unless specified routing instructions are furnished by the customer. Shipments are made daily via U.P.S. and common carrier. Claims for shortages must be made within 10 days. All claims for damages or loss in transit must be made with the carrier. No collect calls will be accepted. To ensure delivery of orders, we need your full street address and phone number. When you receive your shipment, examine it carefully. Be sure all cartons listed on the delivery sheet are accounted for. Large items may be packaged separately. If a carton is damaged, open it and inspect the contents before signing for delivery. If merchandise is damaged, describe damage on the delivery receipt. Failure on your part to document damaged or missing merchandise on the delivery receipt releases the carrier of all liability; repair or replacement will be the customer's responsibility.

WARRANTY. We warrant all new products are free of defects in materials and workmanship.* This warranty is effective if products are properly installed and used for the purpose for which they were intended and applies to the original buyer only. Except as set forth above or in any product-specific warranty documentation, we make no other warranties, express or implied, including but not limited to warranties of merchantability of fitness for a particular use.

Returns of a product for warranty must be accompanied by a Return Merchandise Authorization number (RMA#), obtained by calling Customer Service at 866-748-7435, and sent, with freight paid by us, to Shur-Co®, LLC, 2309 Shur-Lok St., PO Box 713, Yankton, SD 57078. All products returned without an RMA# will be refused. When we issue the RMA#, we will also issue a call tag to have UPS (or other freight company) pick up the product. C.O.D. returns not accepted. We will pay no storage fees for a warranty product return prior to pick by us or the freight company. If a warranty product return is scheduled to be picked up by us, we will pick up the product at our earliest convenience.

If a product returned is found, in our judgement, to be defective in material or workmanship, our obligation under this warranty is limited to the repair or replacement of the product, which will be made by us. Repair or replacement will be at our discretion, with replacements being made using current products performing in the equivalent function. Labor charges, other than those incurred at our factory, including, but not limited to, any labor to install a repaired or replacement product, are not covered under this warranty. All expenses associated with delivering defective products to our factory and delivering repaired or replacement products from our factory to the owner will be paid by us.

If the product returned is found, in our judgement, to be non-warrantable, the owner will be contacted to authorize repair work, purchase of a replacement product or return of the product, all of which will be at the owner's expense. Payment authorization must be received by us before any non-warrantable product is repaired, replaced or returned. All expenses associated with delivering the repaired non-warrantable product, a replacement product or the non-warrantable product from our factory to the owner will be paid by the owner.

In no event will we be liable for any damages of any kind to person, product or property, including but not limited to indirect, incidental, special, consequential or punitive damages, or damages for loss of profits or revenue, even if we have been advised of the possibility of such damages. There are no warranties for used products or products that have been repaired, altered, modified or subjected to misuse, negligence or accident. We will not repair or replace products that fail or malfunction due to ordinary wear and tear, except as expressly noted in a product-specific warranty. Use of non-Shur-Co®, LLC parts in conjunction with Shur-Co®, LLC products will void this product warranty.

*Certain products have specific warranties that differ from this warranty, for example motors and electronics. Product-specific warranty documentation is available for these items. In the event of a conflict between this warranty and a product-specific warranty, the product-specific warranty will govern.

RETURN POLICY. All sales final. See WARRANTY above for return details.

OTHER. All prices, product listings, sizes, weights and manufacturing details are subject to change without notice. No person is authorized to modify the foregoing conditions of sale whatsoever.

SHUR-CO®, LLC SERVICE AND DISTRIBUTION CENTERS

Corporate HQ and Outlet Store

SHUR-CO® of SOUTH DAKOTA
2309 Shur-Lok St., PO Box 713
Yankton, SD 57078-0713
Ph 800.474.8756 | Fax 605.665.0501

ShurTite™ Service Centers

SHUR-CO® of CANADA
490 Elgin St., Unit #1
Brantford, Ontario N3S 7P8
Ph 800.265.0823 | Fax 519.751.3997

SHUR-CO® of SIOUX FALLS
47184 258th St., Suite B
Sioux Falls, SD 57107
Ph 844.573.9322 | Fax 605.543.5469

SHUR-CO® of COLORADO
10220 Brighton Rd., Unit #1
Henderson, CO 80640
Ph 866.355.9173 | Fax 303.289.2298

SHUR-CO® of FLORIDA
3353 SE Gran Park Way
Stuart, FL 34997
Ph 800.327.8287 | Fax 772.287.0431

SHUR-CO® of ILLINOIS
3993 E. Mueller Ave.
Decatur, IL 62526
Ph 866.356.0246 | Fax 217.877.8270

SHUR-CO® of IOWA
3839 Midway Blvd.
Ft. Dodge, IA 50501
Ph 866.356.0245 | Fax 515.576.5578

SHUR-CO® of MICHIGAN
5100 Lakeshore Dr.
Lexington, MI 48450
Ph 800.327.8287 | Fax 772.287.0431

SHUR-CO® of NORTH DAKOTA
1746 4th Ave. NW, Unit A
West Fargo, ND 58078
Ph 877.868.4488 | Fax 701.277.1283

SHUR-CO® of OHIO
1100 N. Freedom, St. Rt. 88 & 14
Ravenna, OH 44266
Ph 866.356.0242 | Fax 330.297.5599

SHUR-CO® of OKLAHOMA
1604 East US Hwy 66
El Reno, OK 73036
Ph 866.356.0243 | Fax 405.262.3842

SHUR-CO® of TEXAS
34505 I-10 West, S. Frontage Rd.
Brookshire, TX 77423
Ph 866.689.0039 | Fax 281.934.3311

SHUR-CO® UK, Ltd.
Unit 41 Rochester Airport Estates
Laker Rd., Rochester, Kent ME1 3QX
Ph +44 (0)1795.473499
Fax +44 (0)871.272.8278

For more information, log on to our website:
www.shurco.com

MESSAGE TO OWNERS

Thank you for buying this tarping system from Shur-Co®. We appreciate your confidence in our products. Please read and thoroughly understand this manual before installing and/or operating this system.

Pay particular attention to important safety and operating instructions, as well as warnings and cautions. The hazard symbol  is used to alert users to potentially hazardous conditions and is followed by caution, warning or danger messages.

Failure to READ AND FOLLOW INSTRUCTIONS could result in failure of your tarping system and/or personal injury. Your trailer requirements may, however, call for minor variations to these instructions.

Please inspect your tarping system periodically. Repair or replace worn or damaged parts to your system.

QUESTIONS? CALL OUR HELP LINE:

1-866-748-7435

MON-FRI 8 AM-5 PM CENTRAL TIME

SAFETY

We at Shur-Co® are concerned with your safety and the safety of all those operating this system. Therefore, we have provided safety decals at various locations on your tarping system. Keep decals as clean as possible at all times. Replace any decal that has become worn or damaged, painted over or otherwise difficult to read. Replacement decals are available through Shur-Co® dealers.

SAFETY INSTRUCTIONS

- 1. Always wear safety glasses during installation.**
- 2. Keep body and clothing clear of moving parts.**
- 3. No other use of this system is authorized, except as designed.**

RUST PREVENTION

To prevent rust, paint all exposed metal, such as weld seams and/or metal exposed by grinding or cutting, with corrosion-resistant paint.

TABLE OF CONTENTS

Hardware Identification..... 1
 Preliminary Groundwork 2
 Hinge Bracket & Motor Installation 3-4
 Drive Shaft & Manual Lock Gear Installation..... 5
 ProTrap® Mounting & Wiring..... 6-8
 Operation..... 9
 Conversion to Manual Crank..... 9
 Replacement Parts..... 10-12

TOOLS REQUIRED

1. Carpenter's Square
2. Plumb Line
3. Drill
4. 3/16" Drill Bit
6. 3/8" Drill Bit
7. 5/16" Drill Bit
8. 7/8" Drill Bit
9. #3 Phillips Insert Bit
10. 5/16" Combination Wrench
11. 3/8" Combination Wrench
12. 10 mm Combination Wrench
13. Tape Measure
14. Hack Saw (metal cutter)
15. 1/2" Combination Wrench
16. 9/16" Combination Wrench
17. 15/16" Combination Wrench
18. Air or Electric Impact Wrench (9/16" socket)
19. 7/16", 1/2" & 9/16" Sockets
20. Ratchet
21. Wire Cutters
22. 1" Combination Wrench
23. Flat Head Screwdriver
24. Pencil or Marker
25. Wire Terminal Crimper
26. 5/16" Allen Wrench (provided)



WARNING

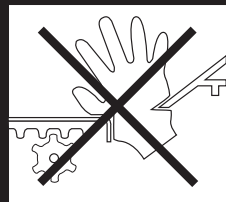

- MOVING PARTS HAVE PINCH POINTS AND ENTANGLEMENT AREAS.
- STAY CLEAR OF DOOR AND MECHANISMS WHEN OPERATING.
- FAILURE TO COMPLY CAN CAUSE INJURY OR DEATH.



CAUTION



- JAMMED OR OVERLOADED DOOR CAN CAUSE MOTOR DAMAGE.
- RELEASE SWITCH IMMEDIATELY IF DOOR STALLS OR REACHES END OF INTENDED TRAVEL.
- FAILURE TO COMPLY CAN CAUSE MOTOR AND EQUIPMENT DAMAGE.

Inspect all parts in your AutoTrap™ kit upon arrival.

A

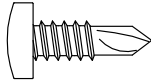

1700398 Self-Drilling Screw - 1/4" x 3/4"

B

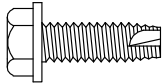

1704338 Self-Tapping Screw - 1/4" x 1"

C

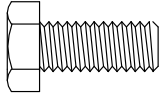

1701045 Cap Screw - 5/16" x 3/4"

D

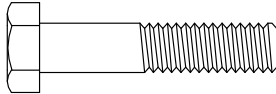

1703487 Cap Screw - 5/16" x 1 1/2"

E

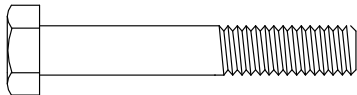

1705083 Cap Screw - 5/16" x 2"

F

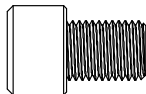

1705476 Socket Hd. Cap Screw - 3/8" x 1/2"

G

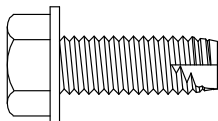

1700400 Self-Tapping Screw - 3/8" x 1"

H

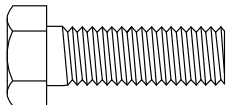

1702904 Cap Screw - 3/8" x 1 1/8"

I

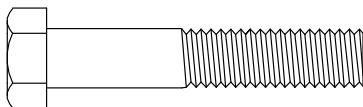

1704264 Cap Screw - 3/8" x 2"

J

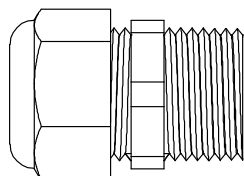

1704152 Dome Nut - 1/2"

K

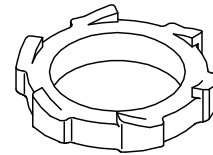

1704187 Lock Nut - 1/2"

M

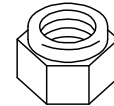

1700419 Nylon Lock Nut - 5/16"

N

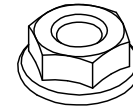

1704946 Flanged Top Lock Nut - 5/16"

P

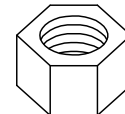

1700407 Hex Nut - 3/8"

R

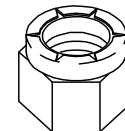

1701580 Nylon Lock Nut - 3/8"

T

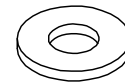

1700427 Flat Washer - 1/4"

U

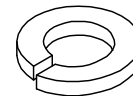

1700434 Lock Washer - 3/8"

V

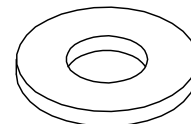

1700429 Flat Washer - 3/8"

NOTE: AutoTrap™ system designed for use with rack and pinion hopper doors only.

AutoTrap™ system designed for use with 1", 7/8" or 3/4" diameter crank shafts.

STEP 1: To determine AutoTrap™ hinge bracket location, transfer center line of crank shaft to upper hopper rail. If there is not already a hole drilled at center line, mark new hole location on upper hopper rail.

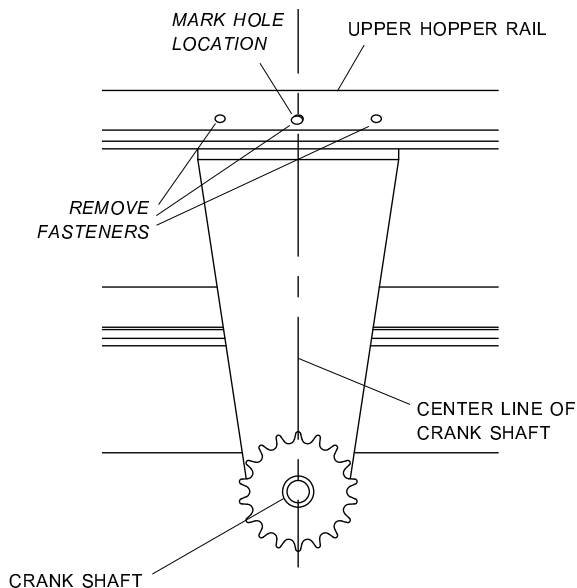

NOTE: Existing crank shaft must be cut in order to connect to new drive shaft on hopper opener.

STEP 2: Measure and mark crank shaft minimum of 5" past U-joint. Cut through shaft at marked location. Remove and discard existing manual crank bracket and hardware.

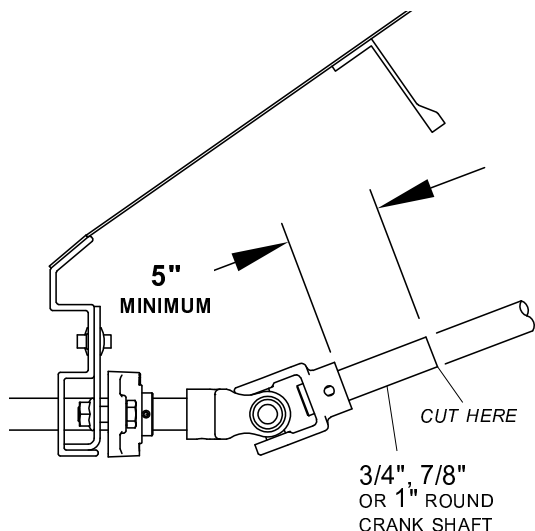

STEP 3: Measure diameter of crank shaft. AutoTrap™ hopper opener will connect to 3/4", 7/8" and 1" round crank shafts using standard adapter included in kit. For other size crank shafts or square/hex-shaped shafts, modify crank shaft or use special adapter as needed.

STEP 4: Determine location to install crank coupler. For 7/8" and 1" round shafts, measure and mark 2" from end of crank shaft. For 3/4" round shafts, measure and mark 2 1/4" from end of shaft.

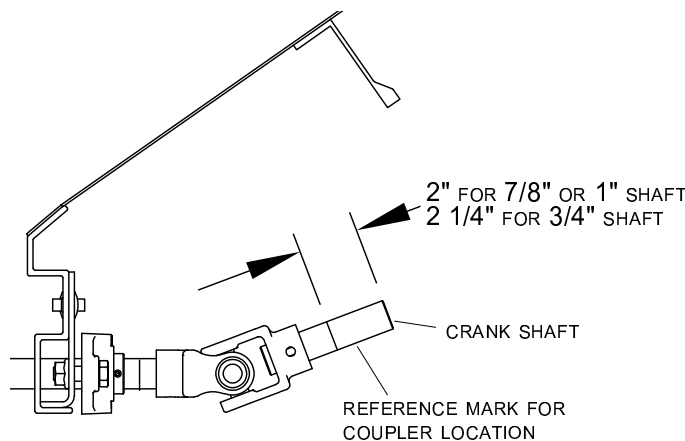

STEP 5: 3/4" shafts only. Slide 1" adapter tube (3/4" inside diameter) over end of 3/4" shaft, aligning with mark made in step 4. Weld adapter tube to crank shaft. Grind smooth any welds that will interfere with sliding coupler onto shaft. Paint welds and adapter tube to prevent corrosion.

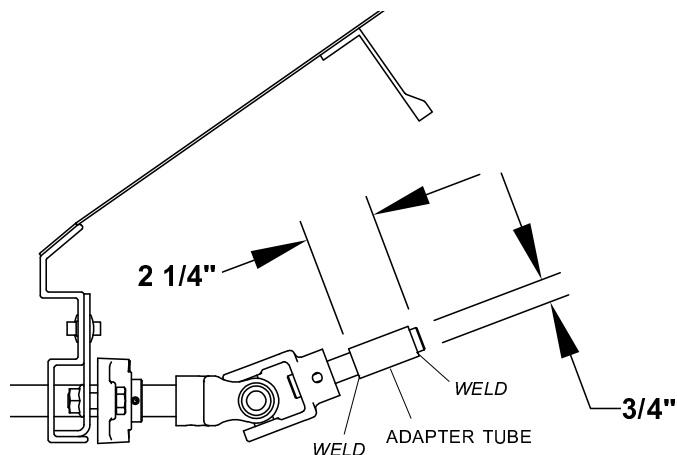

Item	Part #	Description
1.	1118439	Replacement Hinge Bracket
G.	1700400	Self-Tapping Screw - 3/8" x 1"
P.	1700407	Hex Nut - 3/8"
U.	1700434	Lock Washer - 3/8"
V.	1700429	Flat Washer - 3/8"

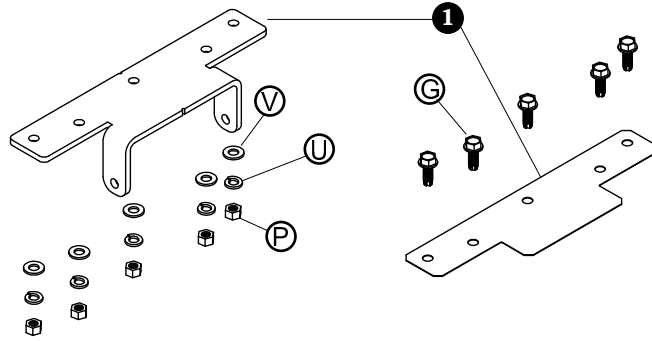

STEP 1: Determine AutoTrap™ hinge bracket location on hopper rail. Mount hinge bracket on upper rail for most applications; mount bracket on lower rail when required. Hinge bracket may be mounted on top or bottom of rail, depending on application.

NOTE: Verify center mark made previously on hopper rail is also centered and square with hopper door cross shaft. If not, adjust accordingly.

If no existing holes on hopper rail align with center of crank shaft: Align notches on hinge bracket with mark on hopper rail (marked in step 2 of previous section).

NOTE: Notches on bracket must align with center line of crank shaft/cross shaft.

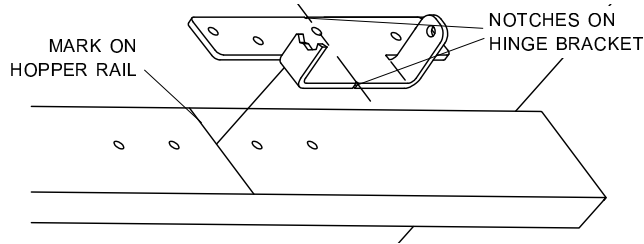

If existing hole on hopper rail aligns with center of crank shaft: Align center hole in hinge bracket with this hole on hopper rail.

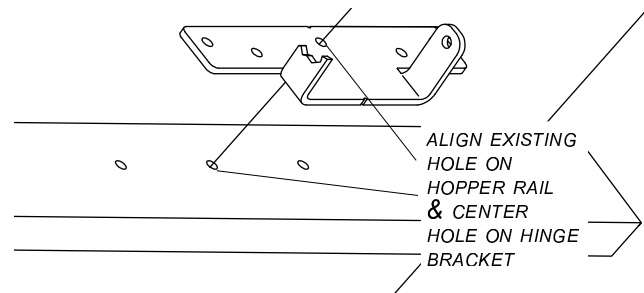

NOTE: Do not fasten hinge brackets to rail at this time.

STEP 2: Assemble hinge bracket to motor mount bracket so hinge bracket will mount to hopper rail as determined in step 1. Fasten with screws (G) and lock nuts (P), leaving fasteners loose enough so bracket can still rotate freely. Fasteners will be tightened securely after drive shaft has been installed.

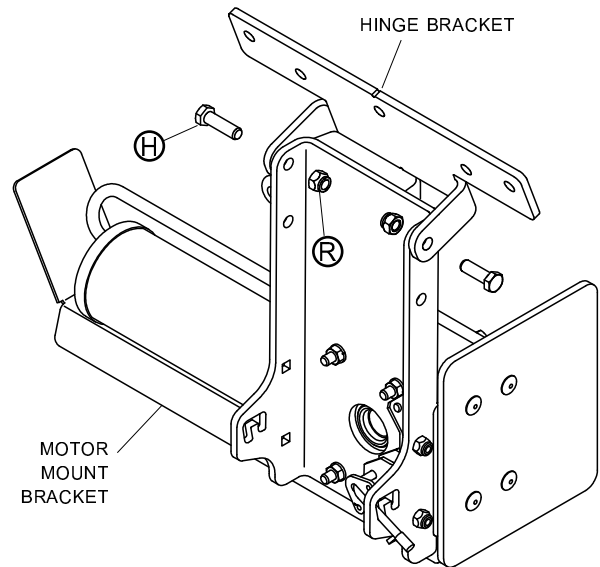

STEP 3: Slide motor adapter bushing and drive shaft into motor so hex end of shaft extends a few inches from face of motor.

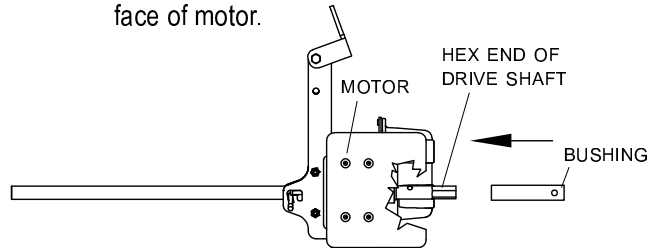

STEP 4: Slide coupler and plastic adapter bushing onto other end of drive shaft.

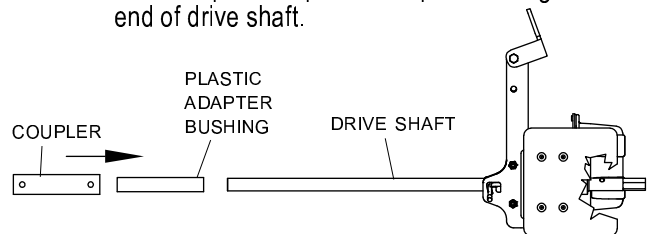

STEP 5: With help of another person, align drive shaft with crank shaft. Slide coupler over crank shaft and against U-joint (for 7/8" diameter crank shaft, slide plastic adapter bushing over crank shaft). Slide bushing inside coupler until it contacts crank shaft.

HOPPER RAIL MOUNT

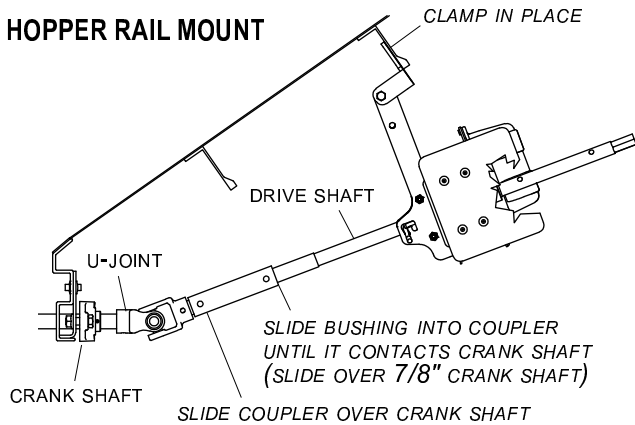

TRAILER RAIL MOUNT

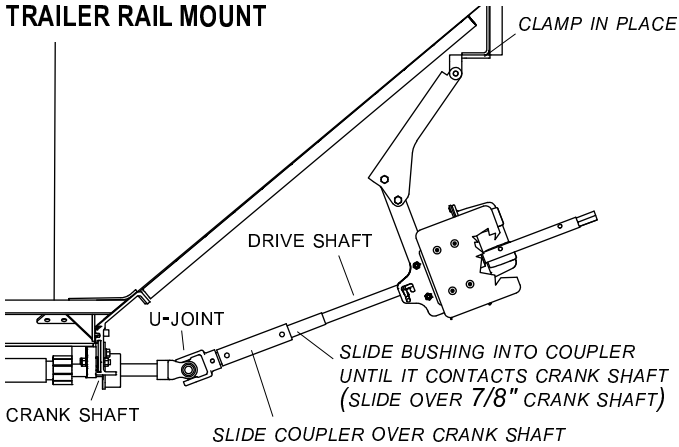

STEP 6: Lift hinge bracket/motor assembly to predetermined location on hopper rail. Keep drive shaft as far into coupler as it will go and allow motor assembly to slide on drive shaft as it moves into position. Clamp hinge bracket to hopper rail.

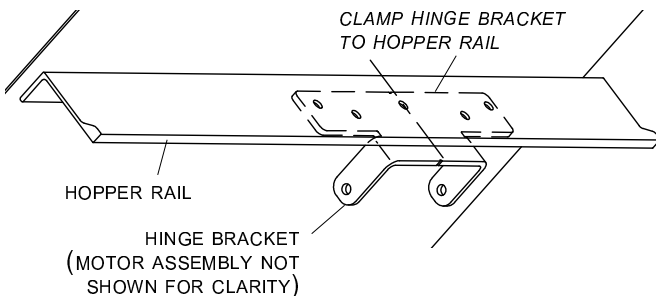

NOTE: Hole in drive shaft will extend past motor. This will be adjusted later.

NOTE: It may be necessary to adjust hinge bracket slightly toward either side of center mark so hinge bracket will line up and sit flat on hopper rail.

STEP 7A: Hopper rail mount. Using hinge bracket as guide, mark and drill 5/16" holes. Slide insulator between rail and hinge bracket and fasten to rail with screws **G**, flat washers **V**, lock washers **U** and nuts **P**.

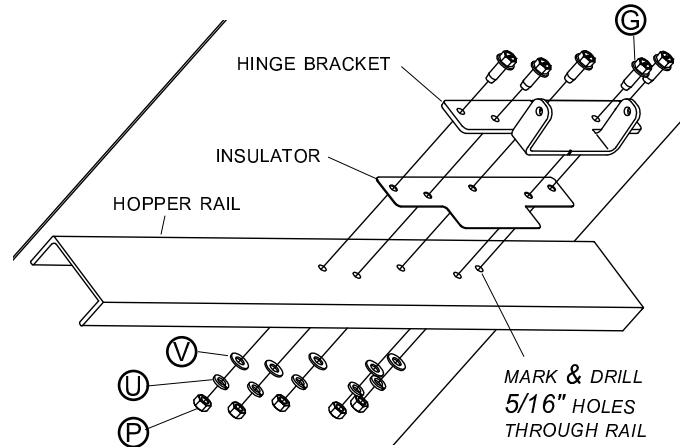

STEP 7B: Trailer rail mount. Using hinge bracket as guide, mark and drill 5/16" holes. Slide insulator between rail and hinge bracket and fasten to rail with screws **G**, flat washers **V**, lock washers **U** and nuts **P**.

OPTION 1

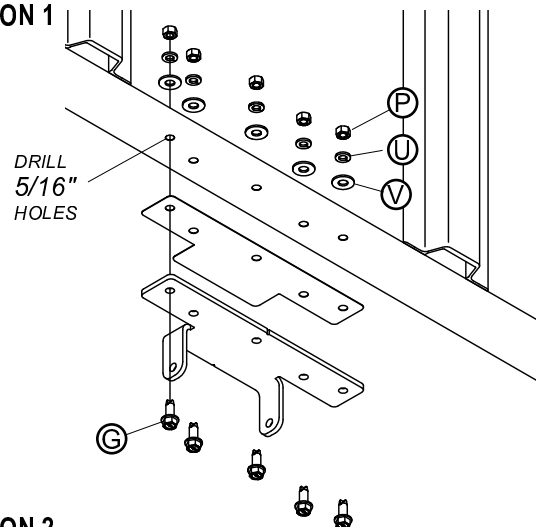

OPTION 2

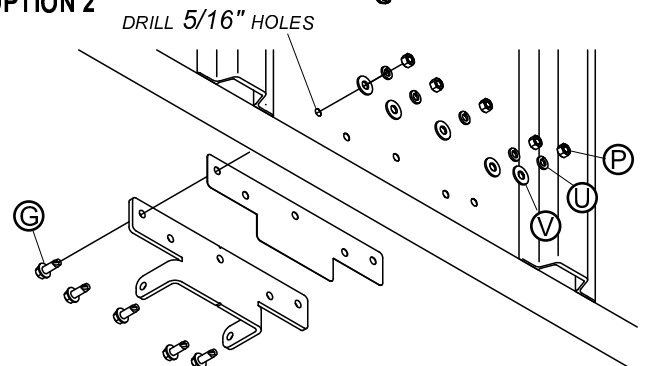

STEP 1: **Cut drive shaft to fit.** Insert drive shaft into coupler as far as possible, so end of shaft contacts crank shaft. Carefully measure center-to-center distance between hole in motor shaft and hole in drive shaft. This distance determines how much needs to be removed from coupler end of shaft.

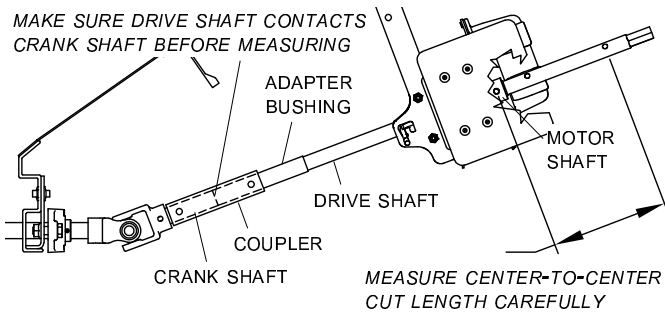

STEP 2: Remove drive shaft from motor. Measure and mark crank shaft at determined distance from coupler end of shaft and cut shaft squarely at this location.

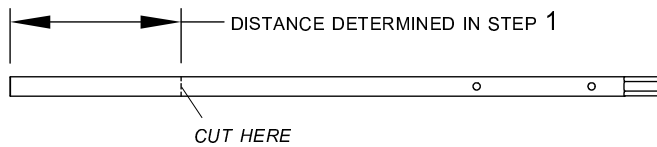

STEP 3: Make sure motor bushing is in motor and hole in bushing aligns with hole in motor. Place spacer washer over short end of manual lock gear hub and hold manual lock gear hub and washer against back of motor mount bracket with hub aligned with motor shaft. Slide drive shaft through front side of motor and bushing, then through spacer washer and lock gear. Fasten drive shaft to motor with screws **F**. Lubricate screws with anti-seize (provided) before installing. Fasten lock gear to drive shaft with screw **D** and nut **M**.

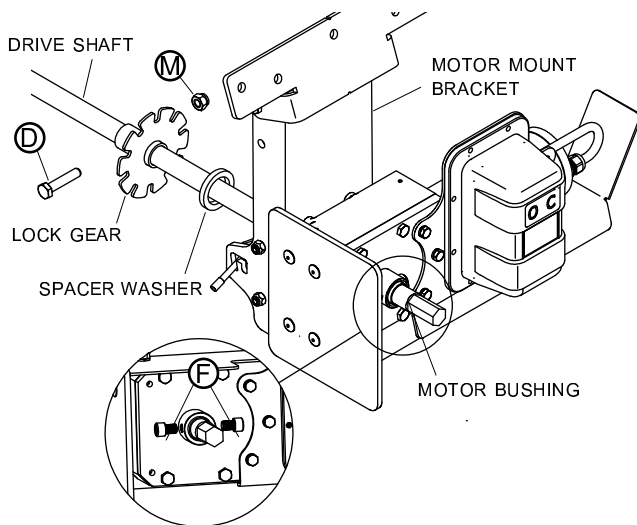

STEP 4: Slide coupler and adapter bushing onto drive shaft. Align drive shaft with crank shaft and slide coupler over crank shaft. Slide adapter bushing into coupler until bushing contacts crank shaft (for 7/8" crank shaft, until bushing is completely inside coupler). Tighten bolts **H** connecting motor bracket to hinge bracket.

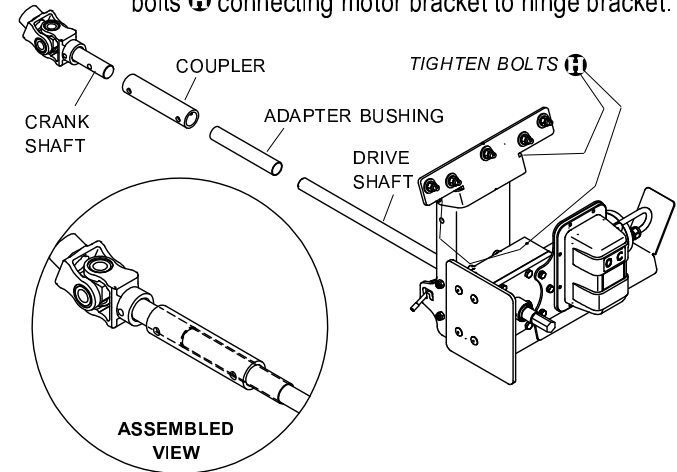

STEP 5: Align lower end of coupler with mark on crank shaft (see page 2, step 4) about 2" from end of shaft (if both shafts are 7/8" diameter, bushing should be over both shafts and completely inside coupler). Use holes in coupler as guide and carefully align and drill 3/8" holes through crank shaft, bushing and drive shaft. Fasten with screws **I** and lock nuts **R**.

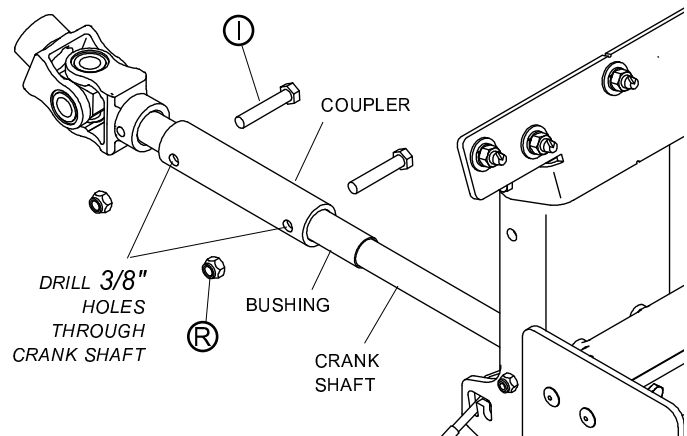

TIP: To help align drill bit, drill halfway through shaft on each side of coupler. Temporarily place 3/8" bolt in halfway drilled hole to keep coupler from rotating while drilling opposite side.

STEP 6: Tighten coupler fasteners and verify all fasteners used in installation have been tightened.

⚠ CAUTION

Make sure manual lock pin is disengaged before operating system or it may be damaged. See page 9 for details.

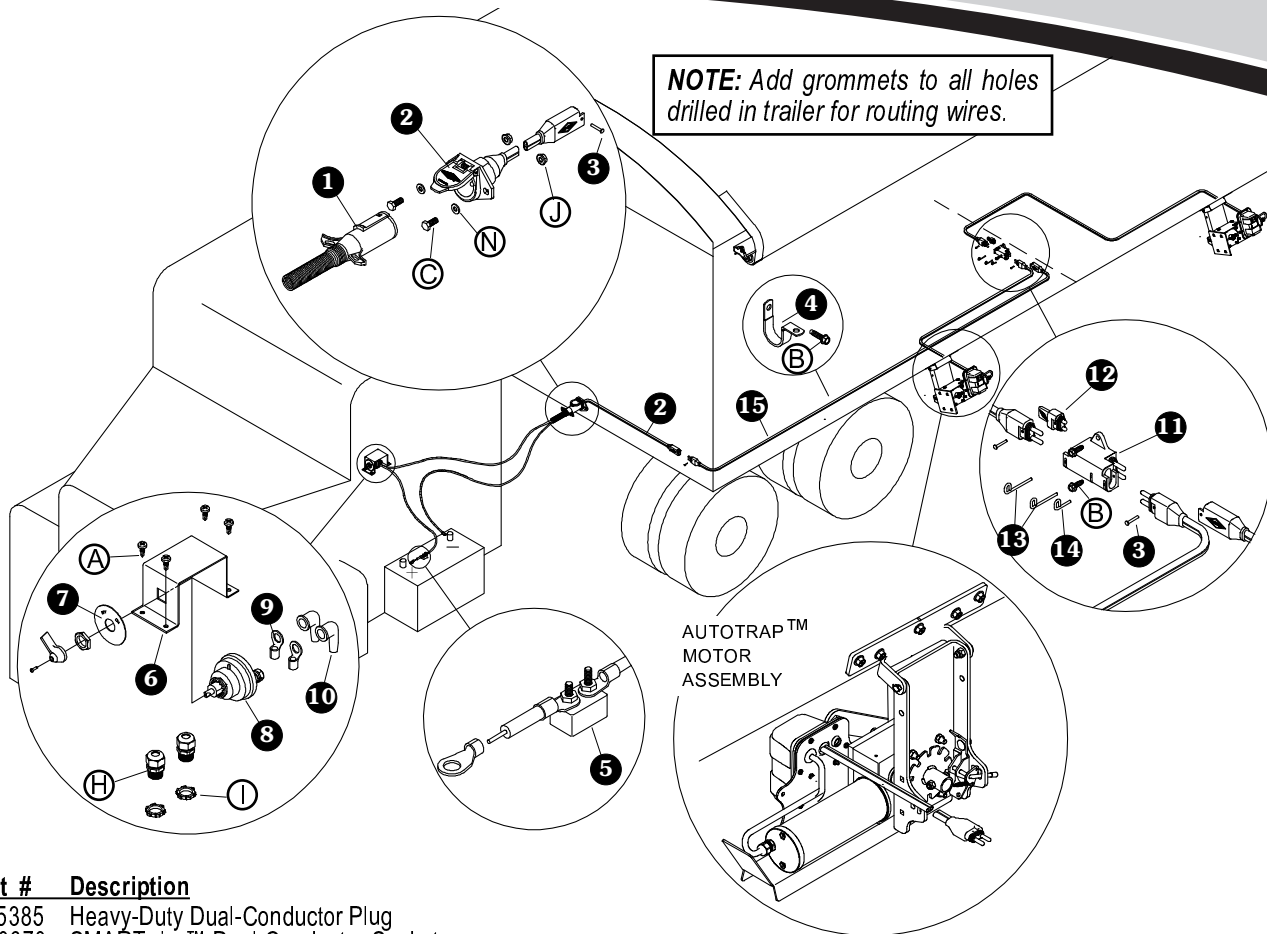

Item	Part #	Description
1.	1115385	Heavy-Duty Dual-Conductor Plug
2.	1120670	SMARTwire™ Dual-Conductor Socket
3.	1704751	Harness Lock Pin - 1/4" x 7/8"
4.	1702108	Wire Clip - 3/4"
5.	1704354	40-Amp Modified-Reset Circuit Breaker
6.	1118323	Disconnect Switch Mounting Bracket
7.	1704284	Face Plate
8.	1704283	Battery Disconnect Rotary Switch
9.	1703244	Ring Terminal - 6 Ga. x 3/8" Stud
10.	1704330	Rubber Insulating Boot
11.	1704695	Harness Junction Block - Black Rubber
12.	1704717	Wire Harness Rubber Plug - Black
13.	1704696	Harness Lock Pin - Long
14.	1704711	Harness Lock Pin - Short
15.		SMARTwire™ - 6 Ga. x 25' - Plug/Socket
	1703231	Cable Tie - 8" (not shown)
A.	1700398	Self-Drilling Screw - 1/4" x 3/4"
B.	1704338	Self-Tapping Screw - 1/4" x 1"
C.	1701045	Cap Screw - 5/16" x 3/4"
H.	1704152	Dome Nut - 1/2"
I.	1704187	Lock Nut - 1/2"
J.	1704946	Flanged Top Lock Nut - 5/16"
N.	1700427	Flat Washer - 1/4"

⚠ NOTICE
 Do not power any Shur-Co® wireless system with battery charger alone, as this will likely cause system abnormalities and/or system malfunction. Instead, use a 12-volt truck/automobile battery to provide power to trailer.

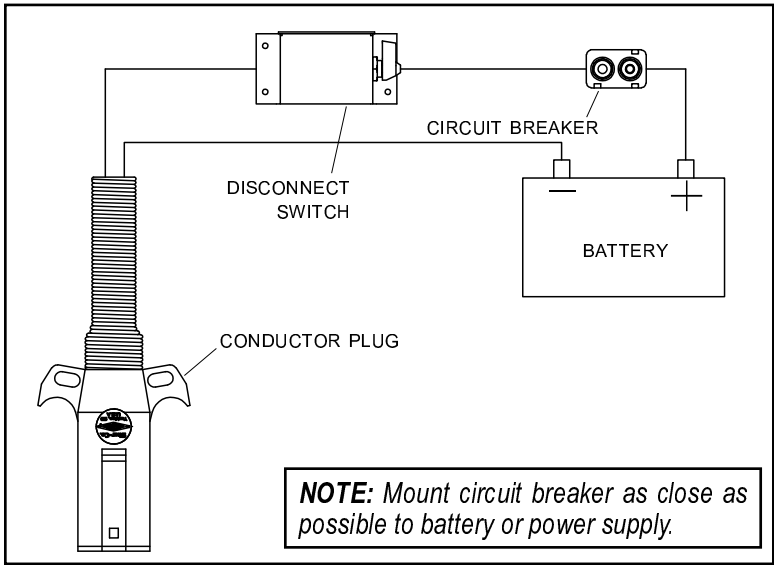

NOTE: Cut wires to length and strip only enough wire insulation to install ring terminals. Insert bare wire into ring terminals and crimp securely.

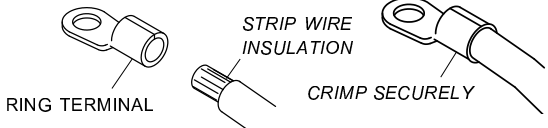

NOTE: Mount circuit breaker as close as possible to battery or power supply.

STEP 1: Drill two 7/8" holes in cab floor to route wire into cab. Install dome nut strain reliefs into holes.

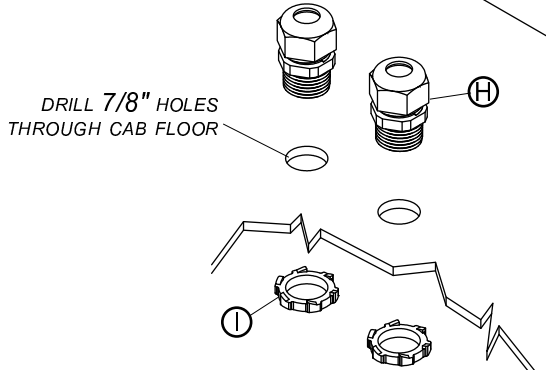

STEP 2: Run positive 4-ga. wire from battery through dome nuts on cab floor. Run wire ends through rubber boots and crimp 3/8" ring terminals to ends of wire.

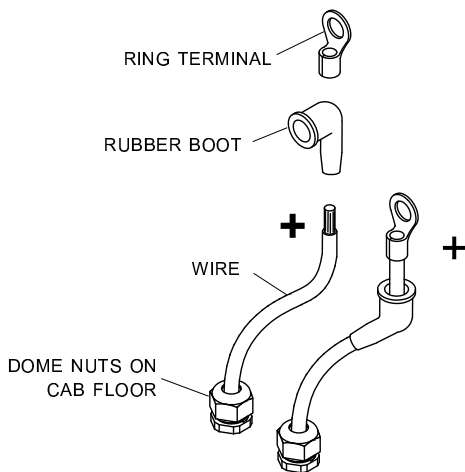

STEP 3: Connect wires to disconnect switch. Coat with dielectric grease and install rubber boots over ring terminals.

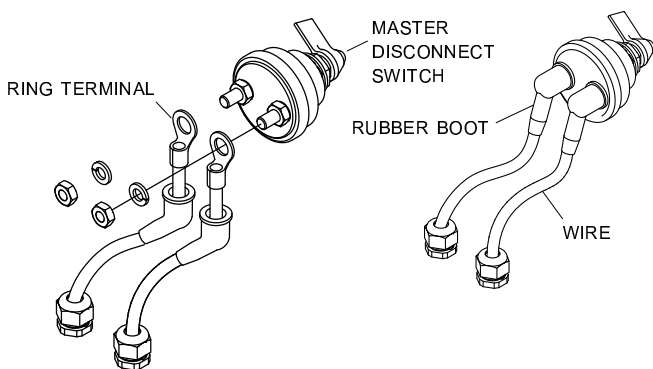

NOTE: Use dielectric grease (P/N 1704378) to prevent corrosion on terminals.

STEP 4: Remove knob and nut from disconnect switch and assemble face plate and disconnect switch to bracket as shown.

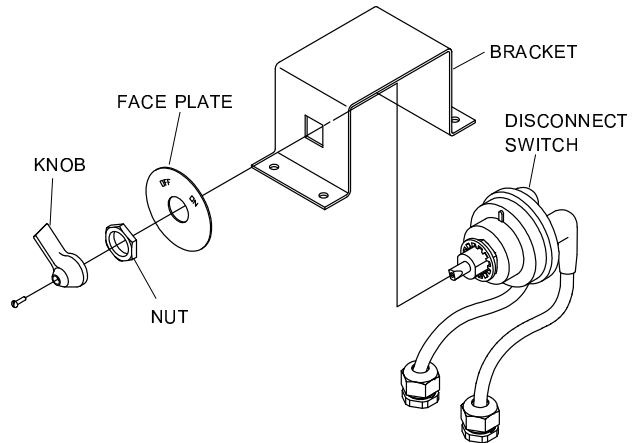

STEP 5: Fasten bracket to cab floor with 1/4" x 3/4" self-drilling screws.

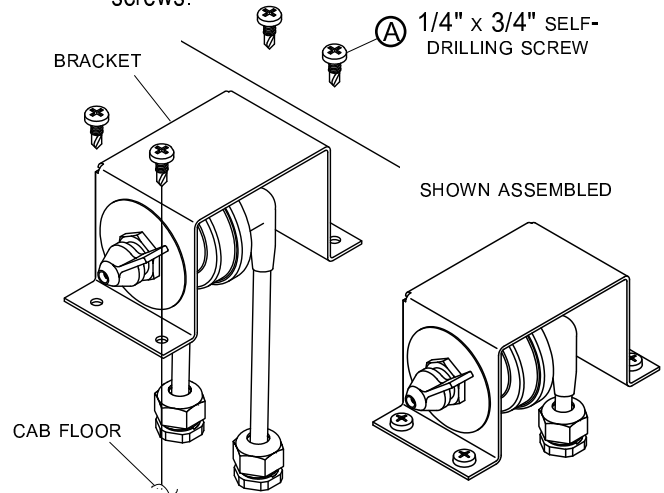

NOTE: AutoTrap™ rocker switch will remain active until master disconnect switch is turned off.

STEP 6: Unfasten and remove insert from conductor plug. Feed 4-ga. wire through plug and into brass contacts on insert. Tighten screws to secure wires. Replace insert into conductor plug and secure screw.

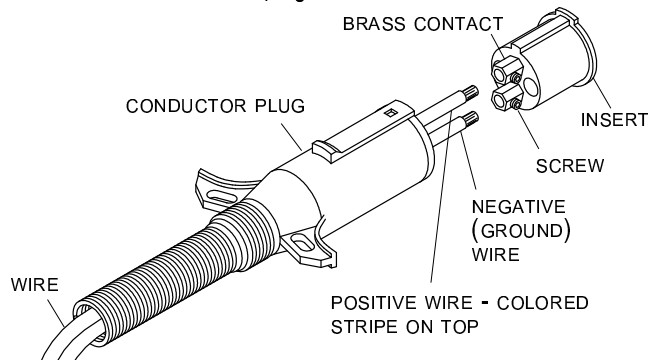

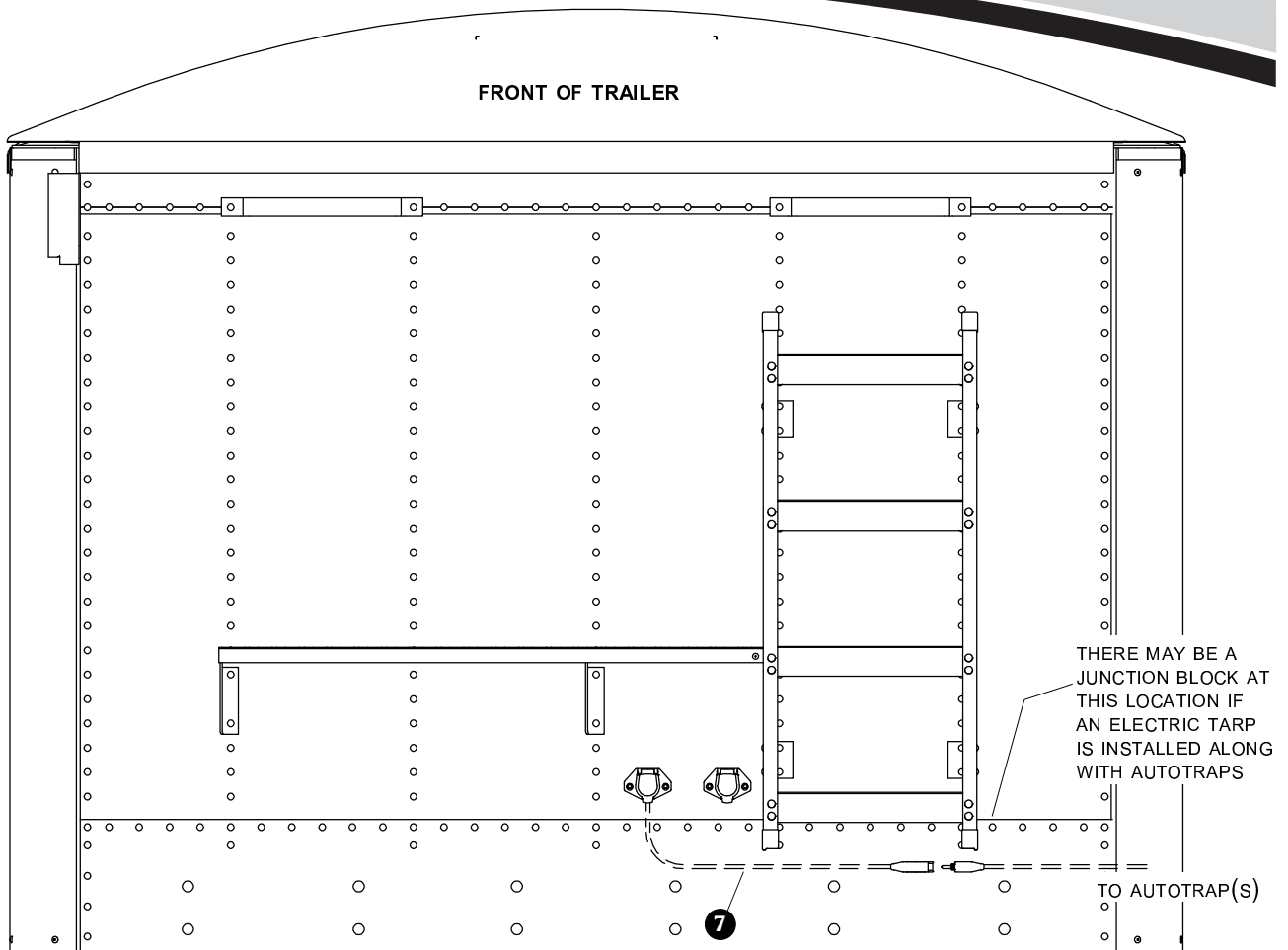

NOTE: Wire lengths are predetermined. Before installing SMARTwire™ components, review and confirm wire routing so that wires will reach components with ample room for connection.

DUAL-POLE CONDUCTOR SOCKET INSTALLATION

STEP 1: Locate dual-pole conductor socket near 7-pole conductor socket as shown. Determine location and drill 2" hole through trailer skin.

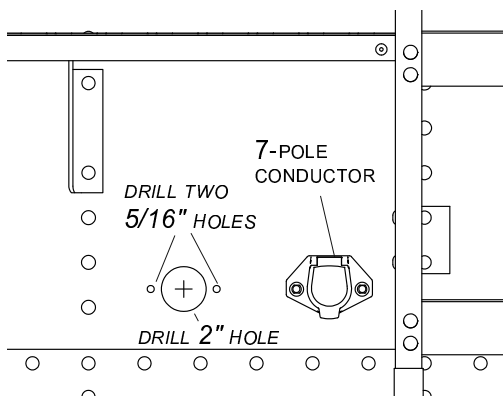

STEP 2: Align socket over 2" hole. Using holes in flanges on socket as guide, mark and drill two 5/16" holes.

STEP 3: Fasten conductor socket to trailer with 5/16" x 3/4" cap screws, flat washers and nuts.

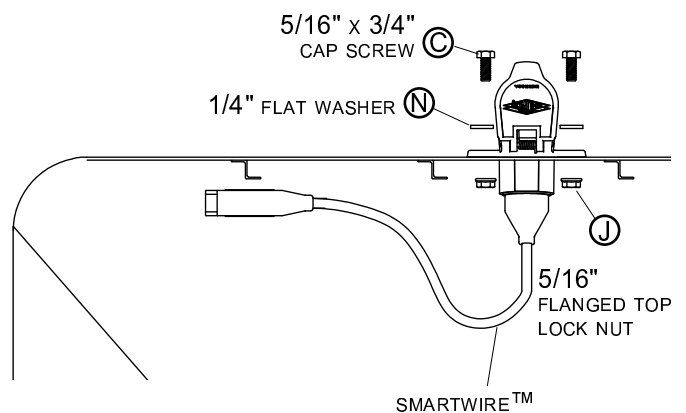



CAUTION

Check all hardware for complete assembly before operating. Inspect system at this time and adjust as required.

Operation:

Close Trap: Push switch to "CLOSE" and hold. Observe trap and release switch when trap is fully closed.

Open trap: Push switch to "OPEN" and hold. Observe trap and release switch when trap is fully open.

Remote operation: Refer to operating instructions included with remote.

NOTE: Release switch at end of cycle or modified-reset circuit breaker will trip. After breaker resets, switch will activate motor again. To reduce unnecessary strain on components, release switch at end of each cycle. SMART2™ systems will automatically turn off at **OPEN** or **CLOSE** side travel limit after having been set. Refer to operating instructions included with SMART2™ remote.

NOTE: Receiver may be pressure washed, but keep nozzle at least 3' from system while spraying.

CONVERSION TO MANUAL CRANK

STEP 1: To change from electric to manual operation, unfasten and remove fasteners connecting motor to drive shaft. Slide back-up crank handle onto hex end of drive shaft. Remove crank handle when not in use.

NOTE: Any 3/4" wrench or ratchet/socket may be used in place of crank handle.

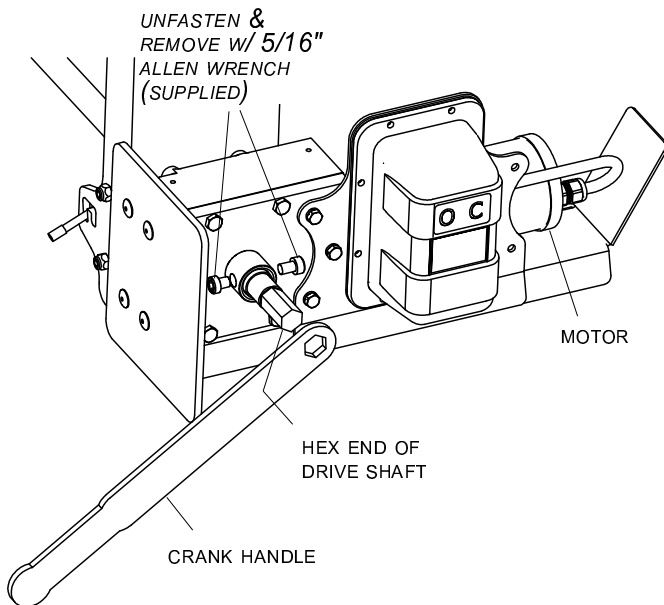

STEP 2: Manual lock pin must be disengaged during electric operation. To lock drive shaft during manual operation, lift handle on lock pin and slide pin into notch in lock gear as shown at right.

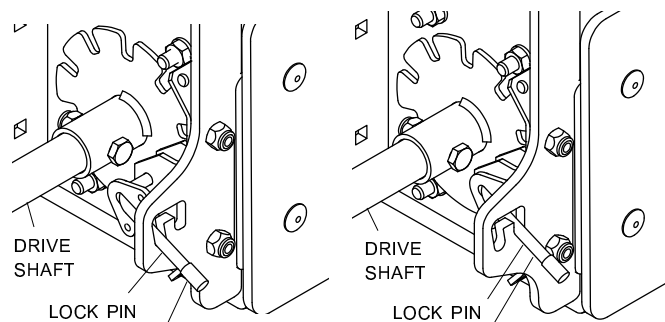

UNLOCKED - DISENGAGED.
DRIVE SHAFT CAN BE
ROTATED BY ELECTRIC MOTOR
OR W/MANUAL CRANK

LOCKED - ENGAGED.
DRIVE SHAFT & HOPPER
DOORS CAN BE LOCKED
IN PLACE DURING MANUAL
OPERATION



CAUTION

Do not operate electric system while lock pin is engaged and drive shaft is locked or manual lock mechanism could be damaged.

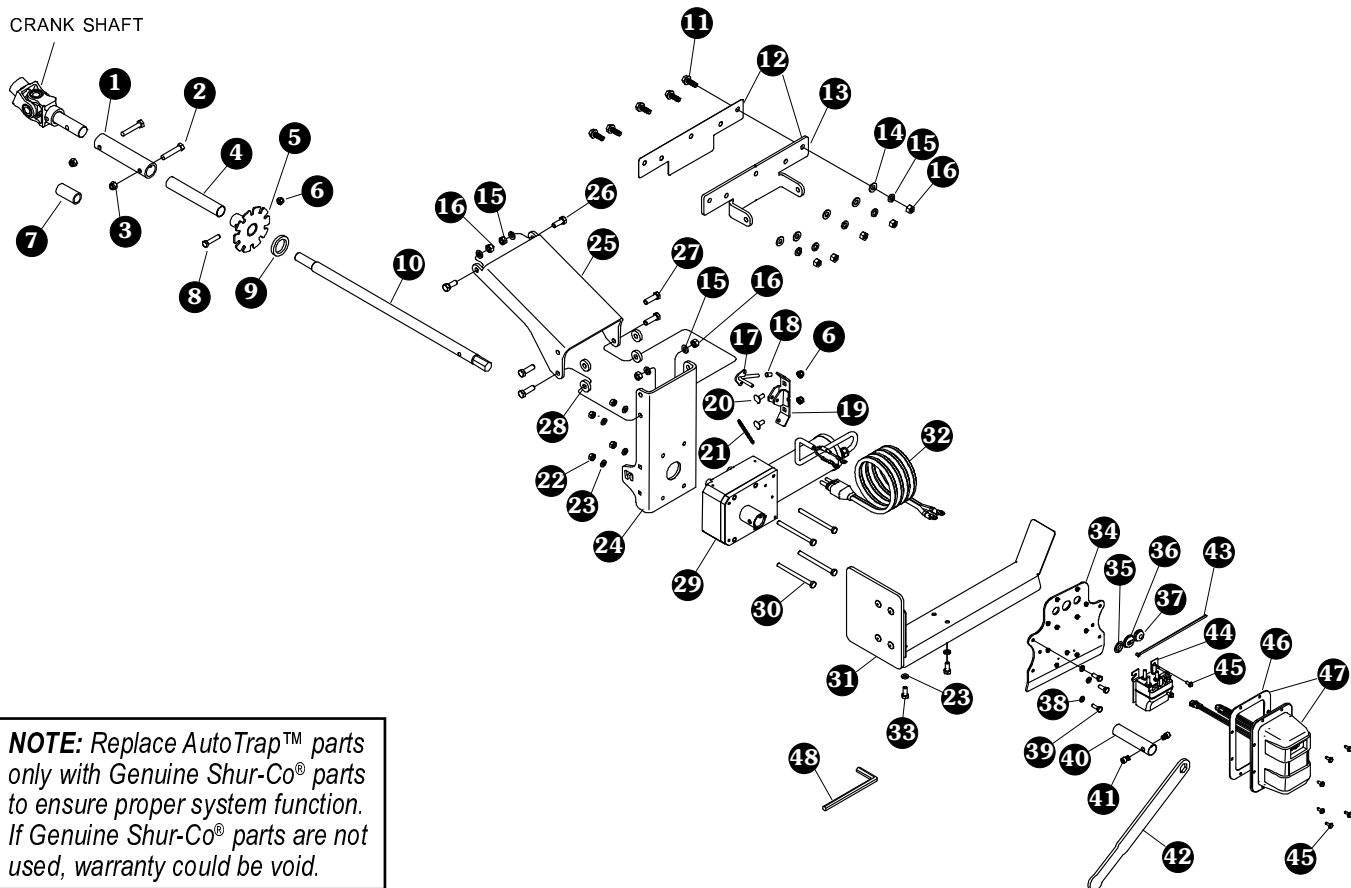

NOTE: Replace AutoTrap™ parts only with Genuine Shur-Co® parts to ensure proper system function. If Genuine Shur-Co® parts are not used, warranty could be void.

AUTOTRAP™ WIRELESS ASSEMBLY

Item	Part #	Description
1.	1123567	Coupling - 1 3/8" x 6"
2.	1704264	Cap Screw - 3/8" x 2"
3.	1701580	Nylon Lock Nut - 3/8"
4.	1705226	Adapter Bushing - .990" OD x .895" ID x 6"
5.	1123565	Manual Lock Gear
6.	1700419	Nylon Lock Nut - 5/16"
7.	1123569	Shaft Adapter - 3/4" to 1"
8.	1703487	Cap Screw - 5/16" x 1 1/2"
9.	1118318	Spacer Washer - 1/4" x 1.81"
10.	1124697	Drive Shaft - 7/8" OD - 3/4" Hex End - 27"
11.	1700400	Self-Tapping Screw - 3/8" x 1"
12.	1118439	Replacement Hinge Bracket
13.	1118277	Shim Insulator
14.	1700429	Flat Washer - 3/8"
15.	1700434	Lock Washer - 3/8"
16.	1700407	Hex Nut - 3/8"
17.	1123557	Lock Pin
18.	1704276	Protective Cap
19.	1123554	Lock Pin Bracket
20.	1705231	Carriage Bolt - 5/16" x 3/4" - Grade 5
21.	1704904	Extension Spring - 7/32" x 1 5/16"
22.	1700411	Hex Nut - 5/16"
23.	1700433	Lock Washer - 5/16"
24.	1123553	Motor Mount Bracket - AutoTrap™

Item	Part #	Description
25.	1123895	Rail Mount Bracket - Auto Trap™
26.	1701061	Cap Screw - 3/8" x 1"
27.	1702891	Cap Screw - 3/8" x 1 1/4"
28.	1120291	Spacer Washer - 1/4" x 1"
29.	1124438	Electric Motor
30.	1705230	Cap Screw - 5/16" x 4"
31.	1124858	AutoTrap™ Debris Deflector
32.	1704716	SMARTwire™ - 6 Ga. M x 1/4" Ring - 10'
33.	1701045	Cap Screw - 5/16" x 3/4"
34.	1124846	Solenoid Bracket
35.	1705258	Button Plug - Flush - 11/16"
36.	1704721	Rubber Grommet - Wire Slot
37.	1705115	Push-In Rubber Grommet
38.	1700436	Lock Washer - 1/4"
39.	1703959	Cap Screw - 1/4" x 3/4"
40.	1705480	Motor Bushing - .990" x 4 3/16"
41.	1705476	Socket Hd. Cap Screw - 3/8" x 1/2"
42.	1123568	Crank Handle
43.	1703231	Cable Tie - 8"
44.	1704312	Motor-Reversing Solenoid - 3 Point Mount
45.	1704308	Flanged Cap Screw - #10 x 1/2"
46.	1704309	Gasket - Solenoid Cover
47.	1123774	Solenoid Cover Assembly w/Gasket - SMART1+™
	1123775	Solenoid Cover Assembly w/Gasket - SMART2™
48.	1705479	Allen Wrench - 5/16"

AUTOTRAP™ TRAILER MOUNTS

Item Part # Description

For Dakota Trailer

- 1118337 Hopper Parts Kit
- 1. 1118305 Bearing Retainer - Dakota
- 2. 1118306 Door Stop - Dakota
- 3. 1700400 Self-Tapping Screw - 3/8" x 1"
- 4. 1700434 Lock Washer - 3/8"
- 5. 1700407 Hex Nut - 3/8"

For Trailer w/Auxiliary Stops

- 6. 1118338 Hopper Parts

For Cornhusker Trailer

- 7. 1118339 Hopper Parts

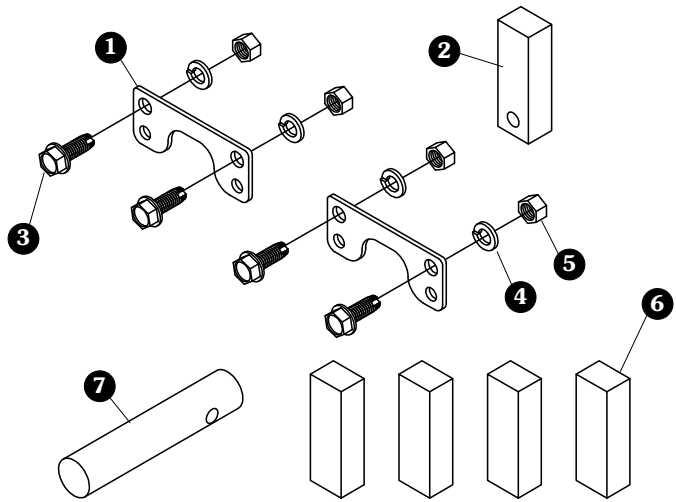

MASTER DISCONNECT SWITCH/CAB WIRING

Item Part # Description

- 1122725 Cab Wiring Kit - Master Disconnect
- 1. 1704284 Face Plate
- 2. 1704283 Battery Disconnect Rotary Switch
- 3. 1700398 Self-Drilling Screw - 1/4" x 3/4"
- 4. 1118323 Disconnect Switch Mounting Bracket
- 5. 1704187 Lock Nut - 1/2"
- 6. 1704152 Dome Nut - 1/2"
- 7. 1703231 Cable Tie - 8"
- 8. 1704354 40-Amp Modified-Reset Circuit Breaker
- 9. 1704330 Rubber Insulating Boot
- 10. 1705105 Ring Terminal - 4 Ga. x 3/8" Stud
- 11. 1705106 Ring Terminal - 4 Ga. x #10 Stud
- 12. 1705107 Dual-Conductor Wire - 4 Ga. 133 Strand (per foot)
- 13. 1704378 Dielectric Connector Protector
- 14. 1115385 Heavy-Duty Dual-Conductor Plug

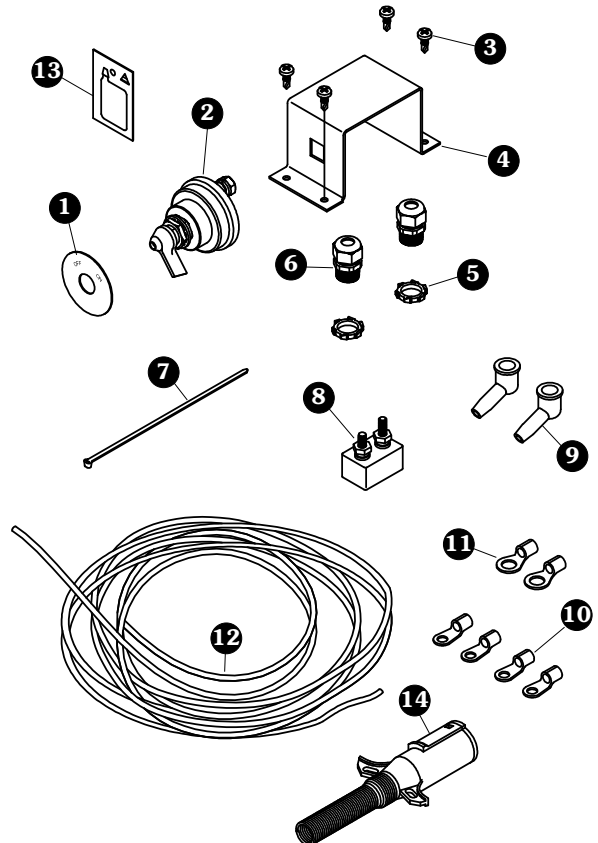

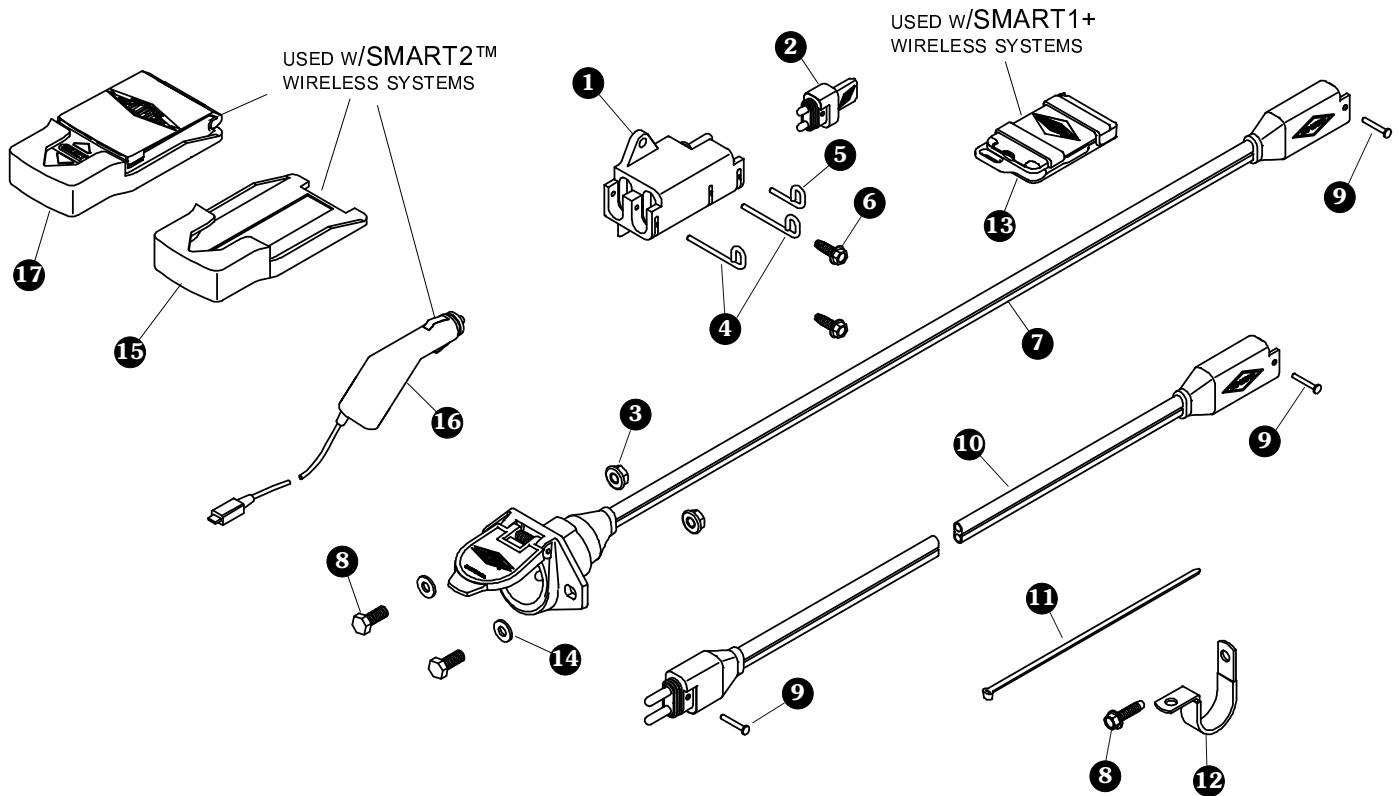

SMARTWIRE™ COMPONENTS

Item	Part #	Description
1.	1704695	Harness Junction Block
2.	1704717	Wire Harness Rubber Plug
3.	1704946	Flanged Top Lock Nut - 5/16"
4.	1704696	Harness Lock Pin - Long
5.	1704711	Harness Lock Pin - Short
6.	1704338	Self-Tapping Screw - 1/4" x 1"
7.	1120670	SMARTwire™ Dual-Conductor Socket
8.	1701045	Cap Screw - 5/16" x 3/4"
9.	1704751	Harness Lock Pin - 1/4" x 7/8"
10.	1704888	SMARTwire™ - 4 Ga. x 25' - Plug/Socket
11.	1703231	Cable Tie - 8"
12.	1702108	Wire Clip - 3/4"
13.	1123160	SMART1+™ Remote - 5-Channel
14.	1700427	Flat Washer - 1/4"
15.	1704957	SMART2™ Transmitter Cradle
16.	1704958	SMART2™ Transmitter Charger Cable
17.	1122231	SMART2™ Transmitter Remote w/Cradle

MORE QUALITY PRODUCTS FROM SHUR-CO®

- **Genuine Replacement Tarps**
- **Genuine Replacement Parts**

- **Agriculture Products**
 - Value Series Shur-Lok®
 - Super Duty Shur-Lok®
 - Shur-Lok® Junior
 - Premium Belt 'n Ratchet
 - Cable-Lok™
 - Turning Point™ Bow

- **SMARTrailer™ Accessories for Agriculture Products**
 - SMART2™ Remote
 - SMART1 +™ Remote
 - 4500 Series HD Electric
 - AutoTrap™ Hopper Opener
 - ProTrap® Hopper Opener
 - LiteALL™ Work Lights
 - Cable-Lok™ Electric Upgrade
 - Electric Turning Point™ Bow
 - Value Series Electric
 - Solar Power Pack

- **Flatbed Products**
 - ShurTite™ Retractable Tarps
 - Stock Lumber & Steel Tarps
 - Steel Tarps

- **Custom Products**
 - Fitted Truck Covers
 - Flat Utility Tarps
 - Bean Drill Covers
 - Shur-Lok® Tarp Cords

- **Construction Products**
 - Super Duty Shur-Lok®
 - Shur-Trak II™
 - Cover-Pro II®
 - Turning Point™ Bow
 - IronSide™ Side-Dump System
 - Arm-Matic™
 - DuraPull™
 - Econo-Pull™
 - Turbo Tarp2 DONOVAN BRAND
 - 2000 Series DONOVAN BRAND
 - 5000 Series DONOVAN BRAND
 - Hammer DONOVAN BRAND
 - Bullet DONOVAN BRAND
 - Flash DONOVAN BRAND
 - Long Arm DONOVAN BRAND

- **SMARTrailer™ Accessories for Construction Products**
 - 4500 Series HD Electric w/Gate Flex™
 - Shur-Trak II™ Electric Upgrade
 - Cover-Pro II® Electric Upgrade
 - Electric Turning Point™ Bow
 - Solar Power Pack

- **Waste Products DONOVAN BRAND**
 - The Ox™
 - Quick-Flip III
 - Sidewinder
 - Sidewinder 350
 - HyTower SL
 - HyTower DL
 - Double-Flip

TARPING SYSTEMS & ACCESSORIES

