

Crank support provides a vertical surface on which to install crank retainer on grain carts with slanted rear panels.

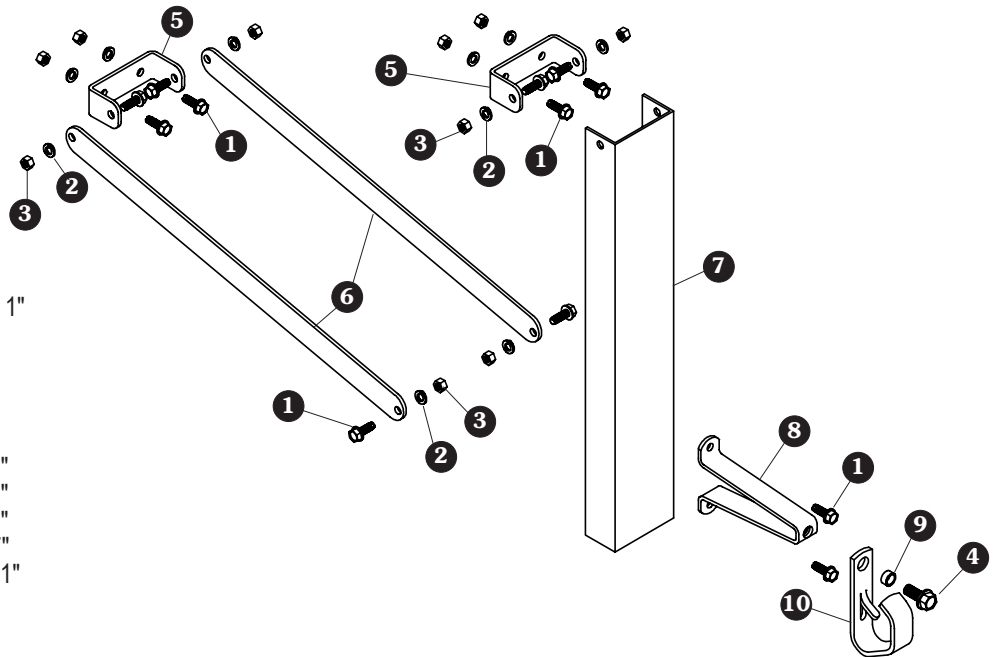

Item	Part #	Description
1.	1700400	Self-Tapping Screw - 3/8" x 1"
2.	1700434	Lock Washer - 3/8"
3.	1700407	Hex Nut - 3/8"
4.	1702996	Cap Screw - 3/8" x 1 1/2"
5.	1116554	Crank Support Base Plate
6.	1116557	Swivel Support Brace
7.	1116555	Crank Support Bracket - 24"
	1120191	Crank Support Bracket - 33"
	1117437	Crank Support Bracket - 42"
8.	1100033	Crank Retainer Standoff - 7"
	1109478	Crank Retainer Standoff - 11"
9.	1100306	Retainer Bushing - 11/16"
10.	1107049	Pinless Crank Retainer

**STEP 1:** Locate crank support where assembly will hold crank arm while tarp is opened or closed. Mark and drill 5/16" holes 2 1/2" apart. Fasten crank support base plate to grain cart with 3/8" x 1" self-tapping screws, lock washers and nuts.

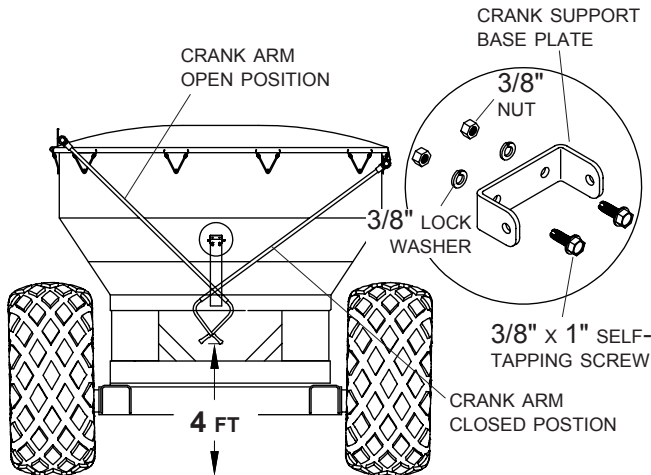

**NOTE:** Crank handle must be at least 4' above ground while tarp is closed.

**STEP 2:** Fasten crank support bracket to crank support base plate with 3/8" x 1" self-tapping screws, lock washers and nuts.

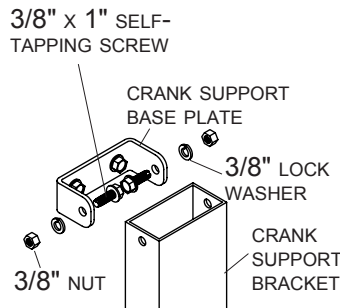

**STEP 3:** Fasten crank support base plate to braces with 3/8" x 1" self-tapping screws, lock washers and nuts.

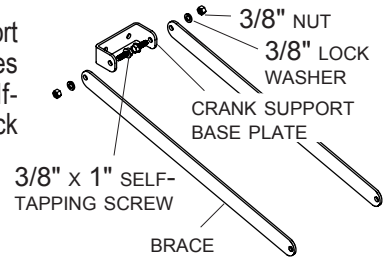

**STEP 4:** Align second crank support base plate to fit crank support bracket and grain cart. Mark and drill 5/16" holes. Fasten base plate to grain cart with 3/8" x 1" self-tapping screws, lock washers and nuts. Fasten to crank support bracket with 3/8" x 1" self-tapping screws, lock washers and nuts.

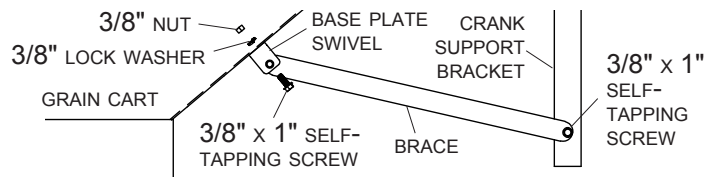

**STEP 5:** Assemble crank retainer and standoff. Mark and drill 5/16" holes along center of crank support bracket and fasten with 3/8" x 1 1/2" cap screw.

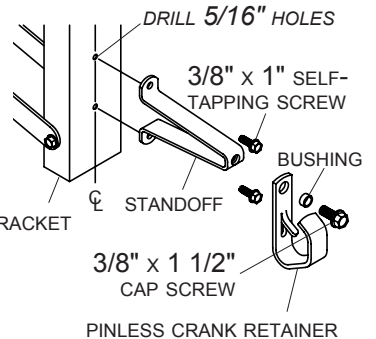

**NOTE:** Position crank retainer where it will hold crank arm while tarp is opened or closed.